

Self-Service Multi-Level Bins

Refrigerated produce merchandiser.

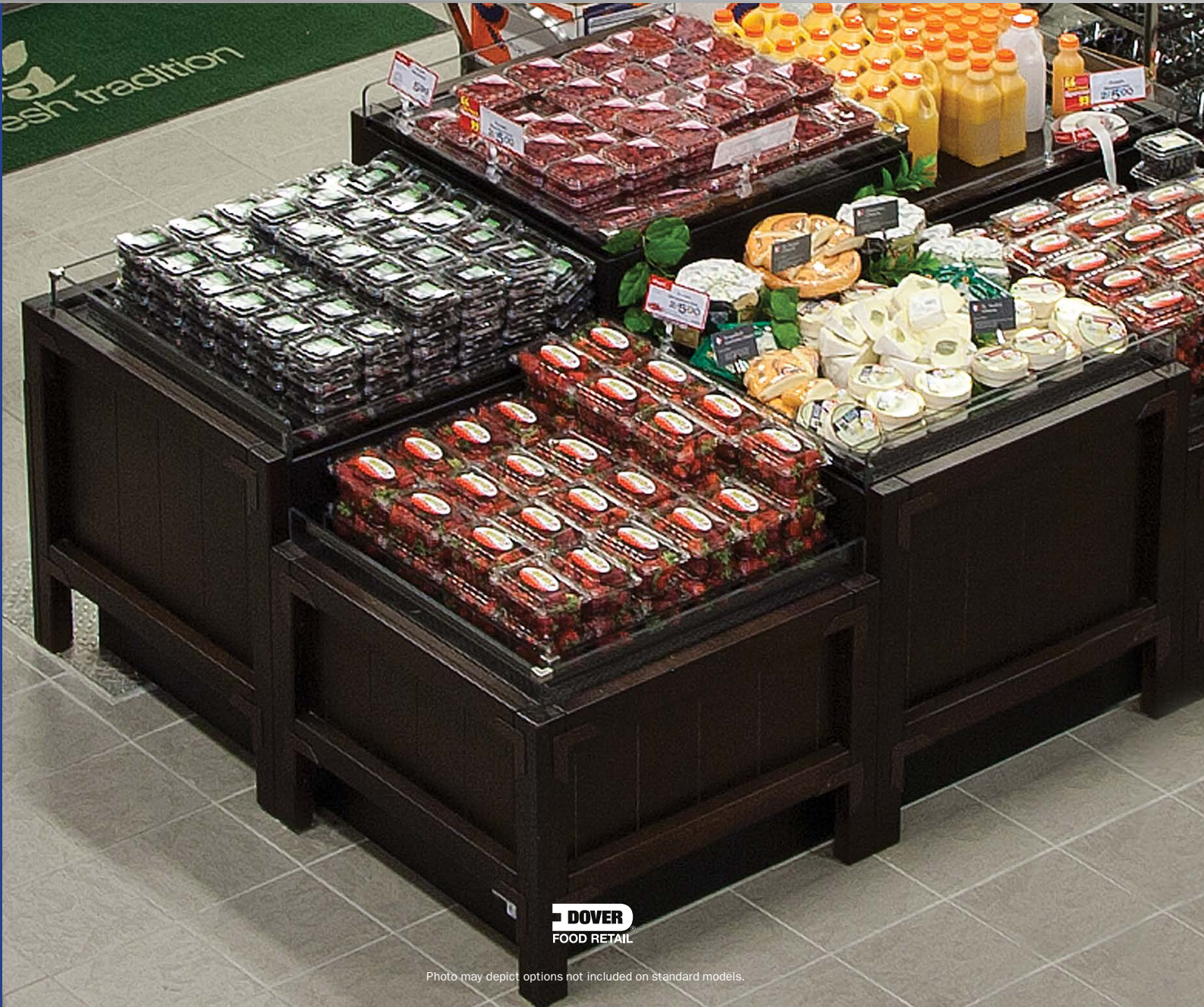
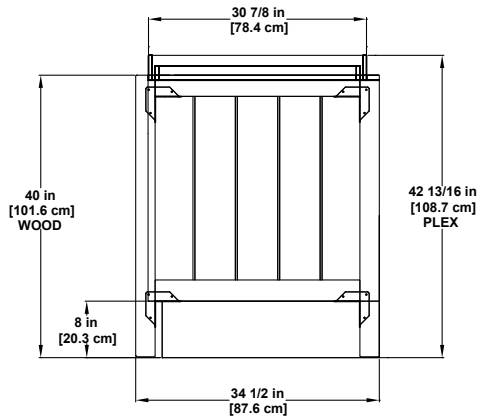

Photo may depict options not included on standard models.



Please consult Hillphoenix Engineering Reference Manual for dimensions, plan views and technical specifications. Specifications subject to change without notice. Designed for optional performance in store environments where temperature and humidity do not exceed 75°F and 55% R.H. Certified to UL 471 and ANSI/NSF Standard 7.

Base Model Features

- Sled runner base construction.
- Standard bin heights 28-3/16", 32-1/2" and 40"H with 8"H toekick height.
- Painted metal exterior.
- Painted exterior trim.
- Painted metal base trim.
- Black powder-coat metal interior.
 - Interior trim to match interior.
- Flat bottom merchandising deck.
- Ballast tray electrical.
- Solar digital thermometer.
- Dieboard plex.
- Plex product stops.
- Energy efficient fans.
- Self-contained refrigeration package.
 - 6' cord and plug.

Available Options

- Casters for base construction recess or non-recess.
- Case configurations:
 - OB-1, 2, 4 and 6 tier.
- Corner brackets painted metal.
- DX, glycol or CO₂ refrigeration package.
- Hardwood clad finish.
- Contact factory for additional self-contained options.



1, 2 and 4 bin self-contained models utilize Second Nature[®] NATURAL environmentally friendly R-290 hydrocarbon refrigerant that has zero (0) ozone depletion potential (ODP) and three (3) global warming potential.

Applicable regulatory body depends on model size:



Dover Food Retail
Conyers, GA USA
844.591.5937
hillphoenix.com

Hillphoenix

©2020 Hillphoenix, Inc.