

# REACH-IN SELF-CONTAINED MERCHANDISER INSTALLATION & OPERATIONS MANUAL

# JNRZHSA/JNRBHSA (R290)

**WARNING / FOR YOUR SAFETY**  
Do not store or use gasoline or other flammable vapors and liquids in the vicinity of this or any other appliance.

**WARNING**  
**R290 flammable refrigerant in use.** Improper installation, adjustment, alteration, service or maintenance can cause property damage, injury or death. Read the installation, operating and maintenance instructions thoroughly before installing or servicing this equipment.

**ACCULINE™**

## Table of Contents

<b>General Information .....</b>	<b>5</b>	<b>Case Cleaning &amp; Fan Maintenance .....</b>	<b>28</b>
<b>Case Installation &amp; Connections .....</b>	<b>6-22</b>	<b>Safety Devices &amp; Service .....</b>	<b>29-31</b>
<b>Case Start-Up &amp; Performance .....</b>	<b>23</b>	<b>Parts Ordering .....</b>	<b>32</b>
<b>Case Details .....</b>	<b>24-25</b>	<b>Appendices .....</b>	<b>33</b>
<b>Pre-Power Checklist .....</b>	<b>26</b>	<b>Addendum: Sequence of Operations .....</b>	<b>81</b>
<b>Airflow &amp; Defrost.....</b>	<b>27</b>		

To ensure proper functionality and optimum performance, it is **STRONGLY** recommended that Hillphoenix refrigerated display cases be installed/serviced by qualified technicians who have experience working with commercial refrigerated display merchandisers and storage cabinets. For a list of Hillphoenix-authorized installation/service contractors, please visit our website at [www.hillphoenix.com](http://www.hillphoenix.com).

**Hillphoenix®**

a **DOVER** company  
P119505H  
R6-V0  
02/26





# Important

At Hillphoenix®, the safety of our customers and employees, as well as the ongoing performance of our products, are top priorities. To that end, we include important warning messages in all Hillphoenix installation and operations handbooks, accompanied by an alert symbol paired with the word "DANGER", "WARNING", or "CAUTION."

All warning messages will inform you of the potential hazard; how to reduce the risk of case damage, personal injury or death; and what may happen if the instructions are not properly followed.

Hillphoenix® recommends that the installers and technicians installing and conducting maintenance of our refrigerated cases must take reasonable care of their own health and safety. As such Hillphoenix® requires the use of safety glasses, ear plugs, steel toed shoes, gloves, arm sleeves, knee guards, back supports and other such personal protective equipment as deemed reasonable for one's safety and protection during the installation and maintenance of our cases or as otherwise required by local ordinance, the general contractor or other governing authority.

 **DANGER**

Indicates an immediate threat of death or serious injury if all instructions are not followed carefully.

 **WARNING**

Indicates a potential threat of death or serious injury if all instructions are not followed carefully.

 **CAUTION**

Indicates that failure to properly follow instructions may result in case damage.

# Revision History

<b>Rev.</b>	<b>Date</b>	<b>Change Description</b>	<b>Author</b>
R0-V0	1/25	New Manual	T.A.G.
R1-V0	3/25	Electrical, Grease Trap, and Tech Sheet Updates	T.A.G.
R2-V0	3/25	Tech Sheets and Addendum: Sequence of Operations	T.A.G.
R3-V0	4/25	Tech Sheets and Addendum: Sequence of Operations	T.A.G.
R4-V0	5/25	Appendix A, Appendix D, and Appendix G	T.A.G.
R5-V0	11/25	Lighting Information and Tech Sheets	T.A.G.
R6-V0	2/26	Pump information, tech sheet updates, and GFCI information	T.A.G.

Thank you for choosing Hillphoenix for your food merchandising needs. This handbook contains important technical information and will assist you with the installation and operation of your new Hillphoenix refrigerated display cases. By closely following the instructions, you can expect peak performance; attractive fit and finish; and long case life.

We are always interested in your suggestions for improvements (e.g. case design, technical documents, etc.). Please feel free to contact our Marketing Services group at the number listed below. Thank you for choosing Hillphoenix, and we wish you the very best in outstanding food merchandising.

## CASE DESCRIPTION

This manual specifically covers the JNRBHSA and JNRZHSA reach-in self-contained merchandisers.

## STORE CONDITIONS

Hillphoenix cases are designed to operate in an air-conditioned store that maintains a 75°F (24°C) store temperature and 55% (max) relative humidity (ASHRAE conditions). Case operation will be adversely affected by exposure to excessively high ambient temperatures and/or humidity.

## REFRIGERATION SYSTEM OPERATION

Air-cooled condensing units require adequate ventilation for efficient performance. Minimum condensing temperatures should be no less than 70°F.

**THIS UNIT CONTAINS R-290 FLAMMABLE REFRIGERANT. USE CAUTION WHEN HANDLING, MOVING OR SERVICING THE DISPLAY CASE. AVOID DAMAGING THE REFRIGERANT TUBING WHICH COULD INCREASE THE RISK OF A LEAK.**

## SHIPPING CASES

Transportation companies assume all liability from the time a shipment is received by them until the time it is delivered to the consumer. Our liability ceases at the time of shipment.

## RECEIVING CASES

Examine fixtures carefully and in the event of shipping damage and/or shortages, please contact the Service Parts Department at the number listed to the right.

## CASE DAMAGE

Claims for obvious damage must be 1) noted on either the freight bill or the express receipt and 2) signed by the carrier's

agent; otherwise, the carrier may refuse the claim. If damage becomes apparent after the equipment is unpacked, retain all packing materials and submit a written request to the carrier for inspection within 14 days of receipt of the equipment.

**Failure to follow this procedure will result in refusal by the carrier to honor any claims with a consequent loss to the consumer.**

If a UPS shipment has been damaged, retain the damaged material, the carton and notify us at once. We will file a claim.

## LOST/MISSING ITEMS

Equipment has been carefully inspected to insure the highest level of quality. Any claim for lost/missing items must be made to Hillphoenix within 48 hours of receipt of the equipment. When making a claim please use the number listed below.

## SERVICE PARTS & TECHNICAL SUPPORT

For service parts questions regarding our cases, please contact our Service Parts Department at 1-833-372-7871 or [orderparts@doverfoodretail.com](mailto:orderparts@doverfoodretail.com)

For technical questions regarding our cases, please contact our Technical Support Department at 1-833-280-5714.

## CONTACTING THE FACTORY

If you need to contact Hillphoenix regarding a specific fixture, be certain that you have both the case model number and serial number. This information can be found on the data tag, located at the top-left interior, rear exterior panel or interior rear lower storage of the case. *Location may vary based on case design.* When you have this information, call the toll-free number listed above.

Hillphoenix  
1925 Ruffin Mill Rd  
Colonial Heights, VA 23834  
Mon.-Fri. (8 a.m. to 5 p.m.)  
Tel: 804-526-4455/Fax: 804-526-1926  
[www.hillphoenix.com](http://www.hillphoenix.com)

# CASE INSTALLATION

## Tools Needed For Installation

- Hammer
- 1/4" Hex Head
- 1/2" Hex Head
- Pallet Jack (J-bar)
- Forklift
- Wrench - 7/8"
- Wrench - 15/16"
- Bubble Level or Laser transit

## Summary of Installation

1. Unload cases from truck (**Receiving**)
2. Prepare cases to go through doorway (**Doorway Prep**)
3. Reinstallation of parts removed once cases are inside the store (**Floor Prep**)
4. Move cases into place and level cases
5. Case installation and trim out
6. Make connections (**Final Install**)

## RECEIVING

1. Upon delivery, begin unloading the cases from the truck by depressing the ratchet to loosen the strap from the case top to the trailer wall that holds the case in place (Fig. 1). Unhook the strap from the wall – save strap for a later step (Fig. 2).



Fig. 1 Decompress the ratchet



Fig. 2 Unhook strap from wall

Remove and discard the wooden floor blocks (Fig. 3) that also hold the cases in place. Also remove the nails that held the floor blocks to the trailer.



Fig. 3 Discard wooden floor blocks

2. Each case includes a base frame that allows for maximum flexibility at delivery (Fig. 4). The base-frame sits on 2" tall feet. If the store has a loading dock, simply push and drag the case off the trailer on its base-frame. Take extra care to not pull on the door handles or lean on the door glass.



Fig. 4 Hybrid base frame

3. Carefully inspect cases for damage before removing them from the truck. Any shipping damage should be noted. Also check if any parts are missing. Then, taking the greatest care possible, unload the cases with a forklift and tow straps (Fig. 5). **Note: Only licensed forklift drivers may operate the forklift using the correct length forks or extensions for the length of the case.**



Fig. 5 Unload with forklift and tow straps

4. Move the cases as close to the store's access, in as safe and easily accessible location, as possible. The cases can be more carefully inspected here once off of the truck (Fig. 6).



Fig. 6 Inspect the case

5. Unpack and prepare the cases for doorway, which includes removing the packing materials that keep the doors and shelves in place during shipping.

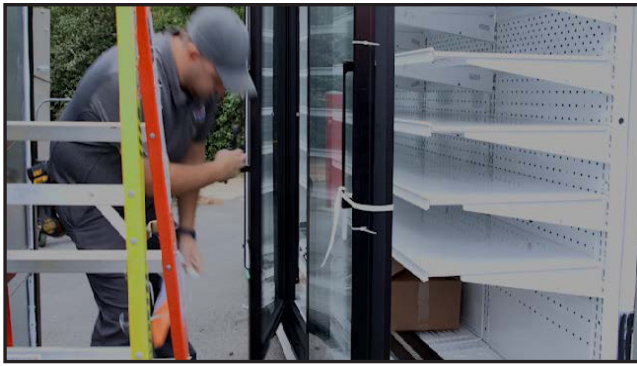


Fig. 7 Remove packing material

**DOORWAY PREP**

Cases with R290 condensing units are shipped with the condensing unit mounted (Fig. 8a). For doorway entry, the condensing unit may have to be removed for any height restrictions. High charge units have condensing unit housing and piping covers that will have to be removed (Fig. 8b). **Note: Low charge units are shipped with the condensing unit balloon guard installed, see step 3 for its removal.**

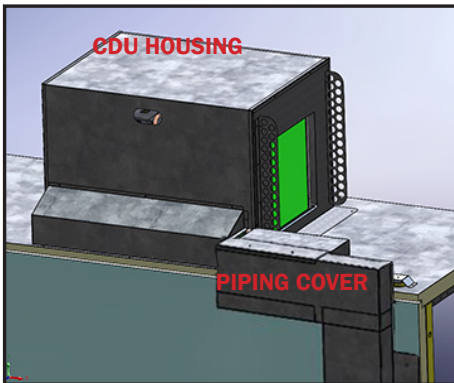


Fig. 8a Case shipped with CDU

HIGH CHARGE (>150) vs LOW CHARGE (<150)				
Model	2 Door	3 Door	4 Door	5 Door
JNRBHA	Low Charge	Low Charge	Low Charge	Low Charge
JNRZHA	Low Charge	High Charge	High Charge	High Charge

Fig. 8b Case charge per length

1. Release the (2) fasteners on the cap of the piping cover with a 1/4" hex head to remove the cap (Fig. 9a). This will expose the piping connections (Fig. 9b).

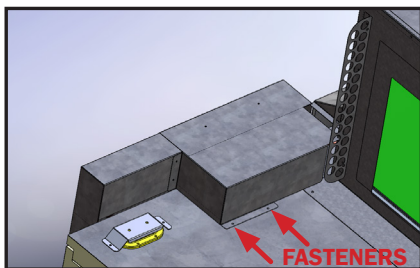


Fig. 9a Location of piping cap fasteners

**⚠ ATTENTION**

Note that the case and condensing unit are shipped charged with refrigerant.

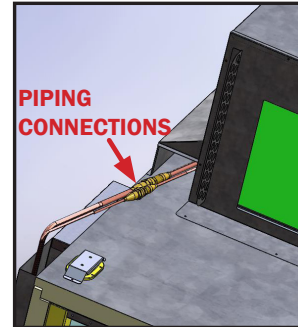


Fig. 9b Remove cap from piping cover

2. On the CDU housing, there are a total of (8) screws that will need to be removed: (3) at the back, (3) on the left, and (2) at the right side (Fig. 10). Once the screws are removed, cover can be lifted and removed (Fig. 11). **Be sure to retain all screws and sheet metal removed.**

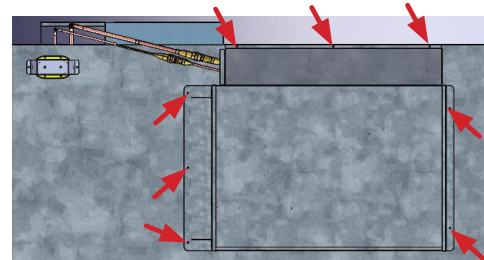


Fig. 10 CDU housing screw locations (top view)

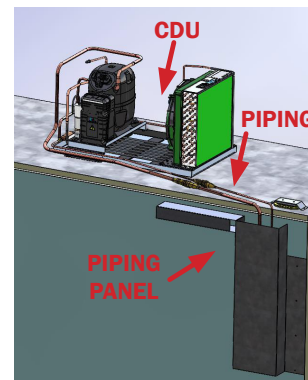


Fig. 11 Remove CDU housing

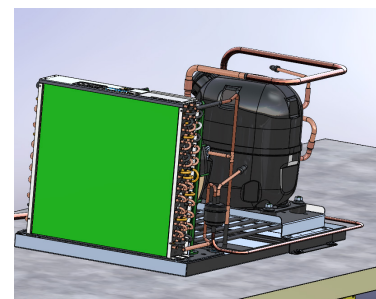


Fig. 12 CDU view

# CASE INSTALLATION

- For low charge cases, the condensing unit balloon guard may need to be removed for doorway entry (Fig. 13). Remove screws connecting balloon guard to top of case and lift housing to remove. **Be sure to retain all screws and sheet metal removed.**

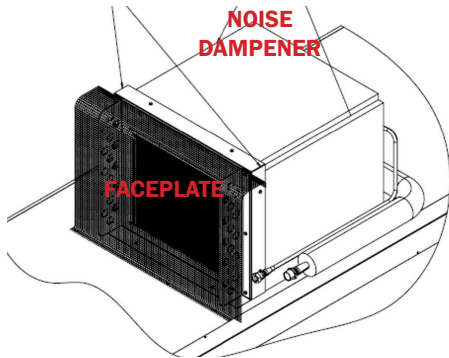


Fig. 13 Low charge housing balloon guard

- With the covers removed, couplings can be disconnected to safely remove condensing unit (Fig. 14). Using a 7/8" wrench, disconnect the male piping connection. Using a 15/16" wrench, disconnect the female piping connection.

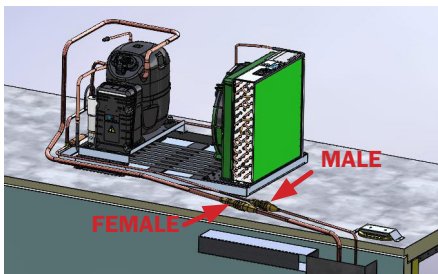


Fig. 14 Male and female piping connections

- Gently, push connections to the rear of the case (Fig. 15) and bend them downward into the rear piping panel (Fig. 16). The piping connections can rest upon the metal cover to the left of the piping cover.

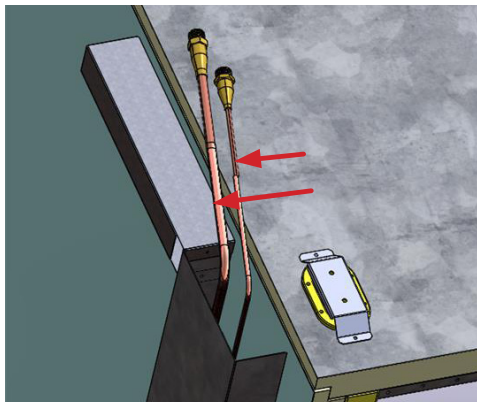


Fig. 15 Push connections towards case rear

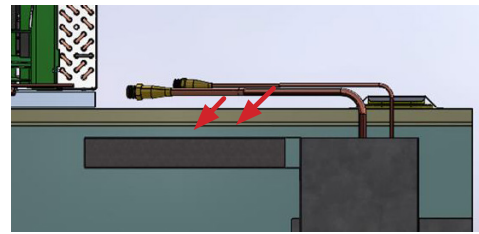


Fig. 16a Bend connections downward

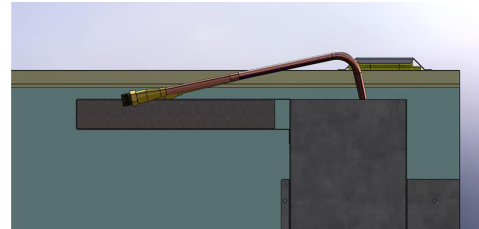


Fig. 16b Final view of piping

- With connections out of the area, screws can now be removed. For 2 and 3-door cases, remove screws attaching CDU to top of the case (Fig 17a) with 1/4" hex head. For 4 and 5-door cases, remove screws attaching CDU to top of the case (Fig 17b-c) with 1/2" hex head.

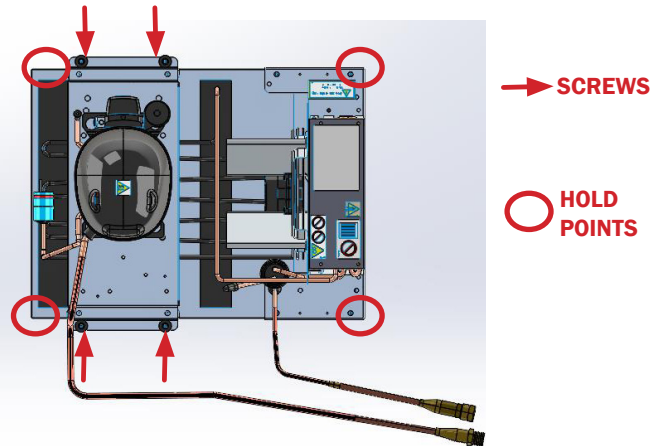


Fig. 17a 2 & 3-door MT CDU screws and hold points

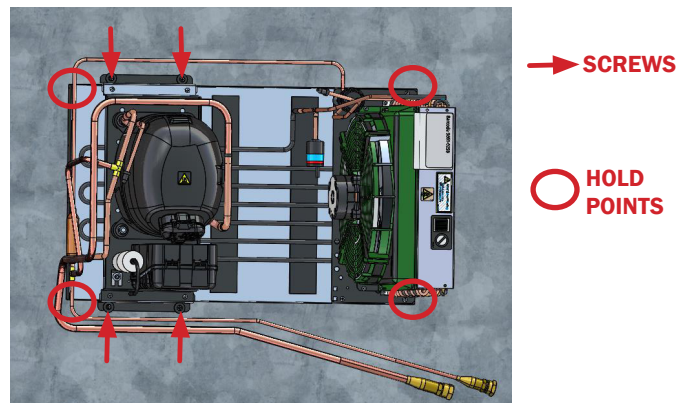


Fig. 17b 3-door LT CDU screws and hold points

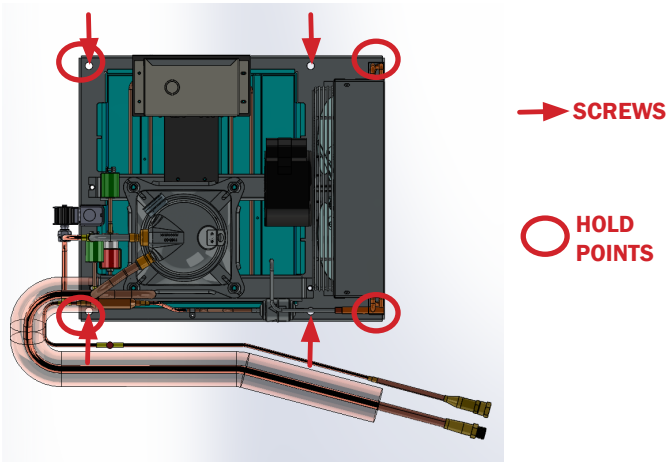


Fig. 17c 4 & 5-door LT CDU screws and hold points

**NOTE:** If case height is still too tall, 0.875" can be gained by removing the egress and cover. **For additional height clearance, the oval egress cover can be removed. If no further height restrictions, proceed to step 6.**

A shipping bracket that covers the oval egress at the top, rear-left of the case helps protect the egress while moving case into the store (Fig. 18). **Do not remove this bracket at this time unless necessary.**



Fig. 18 Oval egress shipping bracket fasteners

- I. Remove the cover and lift the harnesses out of the egress. Secure a drawstring (wire, string or similar) to the harnesses, remove the cover from the harnesses, and attach the other end of the string to the cover. (The drawstring will be needed to retrieve the harnesses later).
- II. Carefully cut the silicone around and under the flange of the egress and gently pry up the egress and remove it from the canopy. Tuck the harnesses into the canopy and let the drawstring, egress and cover hang off the back of the case. Clean any remaining silicone off the egress and the canopy.
- III. When the case has been moved into the store, 2 beads (~1/8"-1/4") of silicone will need to be applied around the egress under flange and ~1/2 way down 3" wall (Fig. 19). Reassemble and seal the egress into canopy. Reinstall 4 screws in egress flange.

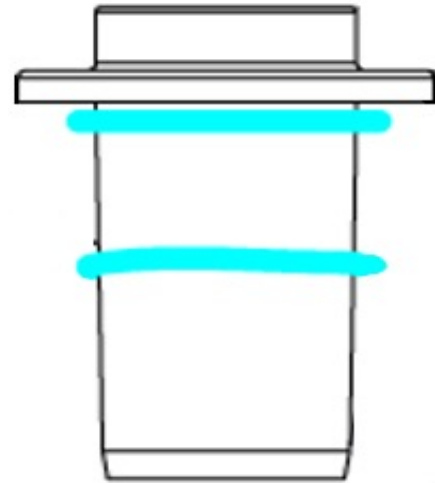


Fig. 19 Apply silicone under flange and ~1/2 way down 3" wall

7. Using a two-person team and the four corners of drain pan as lift points, gently lift condensing unit from the top of the case (Fig. 20) and place in a safe location for later install. Case is ready for doorway entry (Fig. 21).

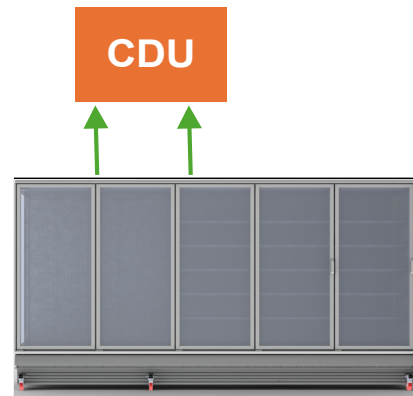


Fig. 20 Remove CDU

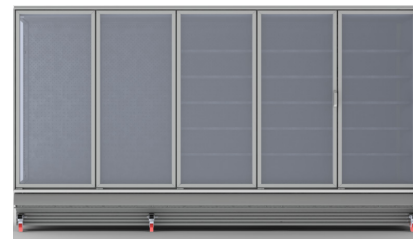


Fig. 21 Ready for doorway

**WARNING:** If lifted through the base feet, pallet blades must extend past the second set of base feet on the case.

**NOTE:** Installers are responsible to comply with all OSHA, local, and store safety requirements. Installers are also responsible to provide equipment adequately sized for the task.

# CASE INSTALLATION

## CAUTION

Use adequate equipment, follow all safety requirements and ensure blades are fully under the case prior to lifting. See Appendix F for Lifting Locations

Extreme care must be taken to ensure safety and to protect the case when using hydraulic pallet-rack jacks or other manual methods. Lift only at designated points on the base-frame (Fig. 22a). Ensure that pallet blades extend past the second set of base feet on the case (Fig. 22b). Avoid causing damage to the drain hub (Fig. 23). The case may also be lifted manually using a J-bar. See Appendix F for more on lifting locations.

**\*Important:** Place the lift blade within the 6" space behind the front foot. Metal reinforcement is provided in this designated lift area.



Fig. 22a Base feet lifting points



Fig. 22b Pallet blades extend past the second set of base feet



Fig. 23 If using a pallet jack, avoid damaging the drain hub (centered left-right on case).

## CASE PREP

Once case is through the doorway, position case approximately 6' away from its final install position.

## Reconnecting the CDU

1. Condensing unit can now be placed back on top of the case using a two-person team and drain pan hold points (Fig. 24). Reinstall CDU screws to secure the unit (Fig. 25a & 25b-c).

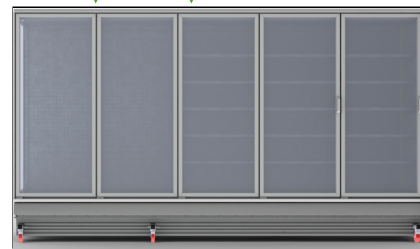


Fig. 24 Reinstall CDU

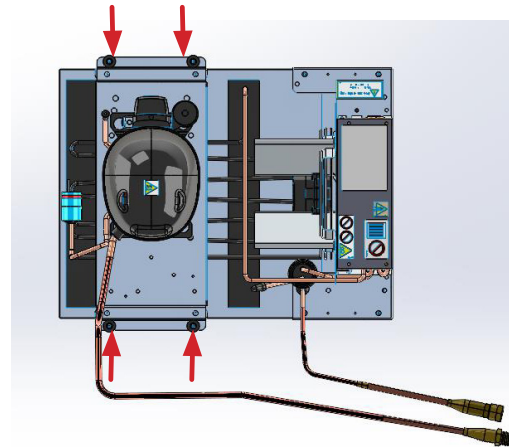


Fig. 25a Reinstall CDU screws (2 & 3 door MT)

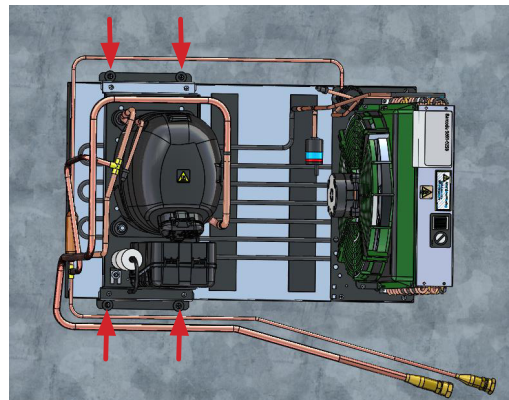


Fig. 25b Reinstall CDU screws (3 door LT)

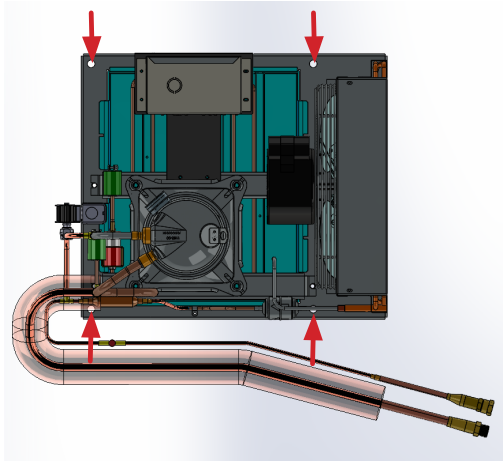


Fig. 25c Reinstall CDU screws (4 & 5 door LT)

2. Bend piping connections back into place and reconnect piping connections using wrenches noted in step 3 (Fig. 26-28).

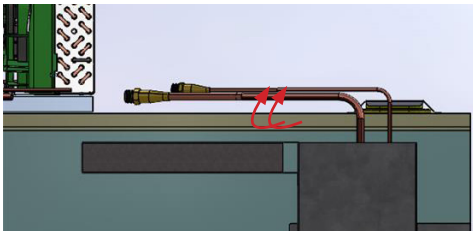


Fig. 26 Bend connections upward

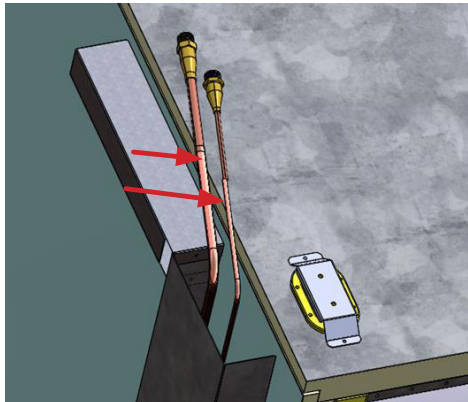


Fig. 27 Push connections towards case front

**! WARNING**

Open or Tighten the Couplings with the following wrench sizes **ONLY**.

**7/8" (22mm) for MALE**  
**15/16" (24mm) for FEMALE**

**TIGHTENING TORQUE MUST BE IN THE RANGE OF 30-35 NM (22-25 FT-LBS)**

P119978G

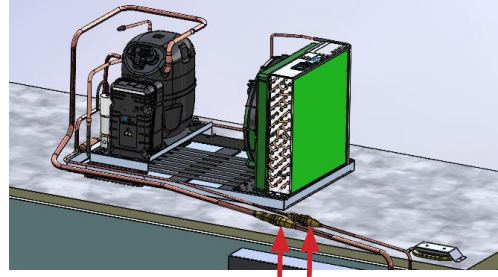


Fig. 28 Reconnect piping connections

**Leak Mitigation Blower Sub-System (High Charge Cases)**

3. With the cases 6' away from final position, high charge cases can now have the Leak Mitigation Blower Sub-system (Fig. 29) can be installed, allowing enough space for the drain to be assembled. The Leak mitigation Blower sub-system consists of the Blower sub-assembly and the Drain Adapter (New) sub-assembly. **Note: Blower sub-system is not required on any low charge case models. For those cases, skip to Level Cases on the next page.**

**! CAUTION**

The blower sub-system requires adequate access to the rear and bottom of the case. Hence, to ensure a trouble-free installation, it is recommended to assemble it on the case before installing it along the wall or into an existing lineup.

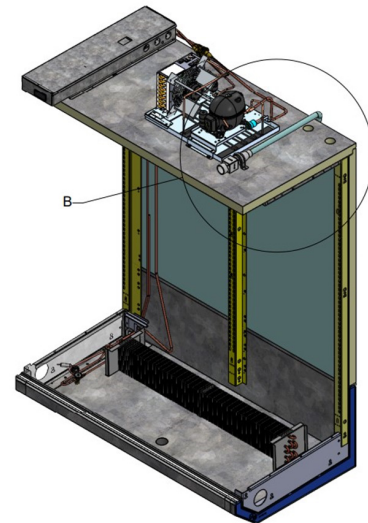


Fig. 29 Blower sub-assembly

4. Install the PVC Drain Adapter to the Drain spout at the bottom of the case. Before gluing the PVC parts, ensure the barb fitting on the T-section is pointing to the rear of the case (Fig. 30).

## CASE INSTALLATION

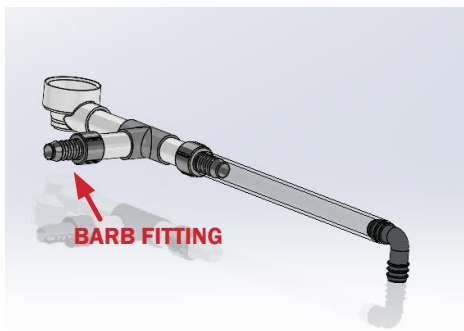


Fig. 30 Install PVC Drain Adapter

5. Once the Drain Adapter is secured, attach the Long Vinyl tubing to the rear-facing barbed fitting (T-section) (Fig. 31).

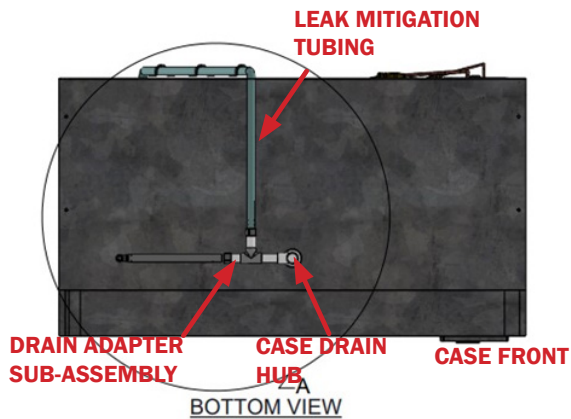


Fig. 31 Long vinyl tubing

6. Now connect the other end of the Vinyl tubing to the Ship-loose PVC Blower (Fig. 32). The Blower must always be located behind the CDU or CDU metal housing. It must be secured with a ship-loose clamp on its adapter body.

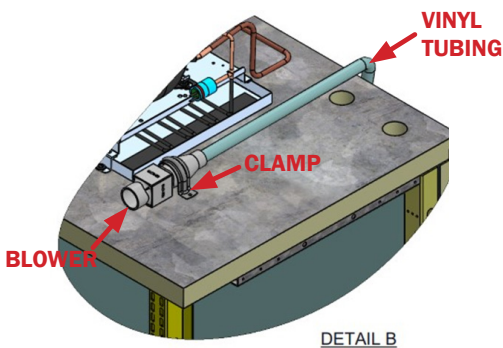


Fig. 32 Vinyl tubing to PVC blower

7. Now fix 3 of the tubing clamps provided in the package at equal intervals at the rear of the case. While fitting the clamps ensure there is sufficient slack in the tubing of the assembly to prevent any form of tension or breakage at the drain adapter (Fig. 33).

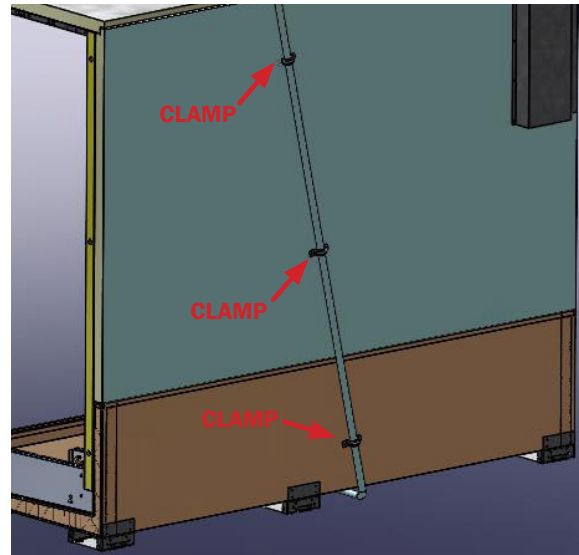


Fig. 33 Tubing clamps

### 8. DRAIN AND PUMP INSTALLATION

There are three drain solutions briefly explained below, with more detailed instructions on the following page.

- STANDARD (Pump):** The tube from the case drain *assembles* onto the barb fitting on the pump. The second tube is fitted onto the barbed fitting on the pump and is then routed to the CDU evap pan on top of the case.
- OPTIONAL (Filtered Pump):** The tube is routed to the grease trap and secured with zip tie. The second tube is fitted onto the barbed fitting on the pump and is then routed to the CDU evap pan on top of the case. See Drain and Pump section on page 13 for more details.
- OPTIONAL (Floor Drain):** The tube from the case is routed to a floor drain located in the store.

## Condensate Tubing Installation Instructions for Drain Options a (Standard Pump) and b (Filtered Pump)

### Objective

To install and route condensate drain tubing from the pump (with tank) to the CDU evaporator pan/tray, ensuring proper drainage and secure fastening for stable operation across JNRB/ZHSA Units.

### Required Components

- Option 1 (**Standard**): Submersible pump with tank (115V, 60Hz)
- Option 2 (**Optional**): Grease trap with integrated condensate pump (use only if specified by project requirements)
- Clear tubing (3/8" O.D., supplied with pump kit)
- Clamps for securing tube
- Zip ties for securing tube
- Power source for pump (115V connection)
- Pump tube fitting + 90° brass elbow

### Installation Steps

#### 1. Position Condensate Pan and Pump

- Ensure the condensate tank is level and securely positioned.
- Completely submerge the pump inside the tank.
- **Standard** Configuration: Use submersible pump with tank.
- **Optional** Configuration: Use grease trap with integrated condensate pump if required by project specifications.

#### 2. Connect Tubing

- Thread the pump tube fitting + 90° brass elbow to the pump outlet.
- Attach the clear tubing (3/8" O.D.) to the pump outlet fitting.
- Cut tubing to the required length to reach from the pump outlet to the inside of the CDU evaporator pan/tray.
- Ensure a snug fit at the outlet to prevent leaks.

#### 3. Route Tubing

- Gently route the tubing from the tank toward the CDU evaporator pan/tray.
- Avoid sharp bends or kinks to maintain smooth condensate flow.

#### 4. Secure Tubing

- Guide the 3/8" clear tubing from the pump outlet toward the CDU evaporator pan/tray.
- Insert tubing into the dedicated clamp located

on the CDU base plate and tighten securely, avoiding overtightening.

### 5. Electrical Connection

- Connect the pump to a 115V power source.
- Verify pressure-activated switch operation:
- Pump activates at ~1.6 in water level.
- Pump shuts off at ~1.3 in water level.

### 6. Final Checks

- Confirm tubing is securely fastened with no movement or sagging.
- Pour water into the tank to activate the pump and verify flow into the CDU evaporator pan.
- Inspect for leaks, misalignment, or hose movement.
- Ensure pump cycles correctly and tubing remains secure.

### DRAIN AND PUMP (Low Charge Cases)

Current configurations of the case will be equipped with a pump and condensate pan (46a). The optional method uses a PVC drain and a grease trap with an integrated pump (Fig. 46b).

1. Unpack the PVC drain and grease trap. Remove all packing material.



Fig. 46a Pump and Condensate Pan

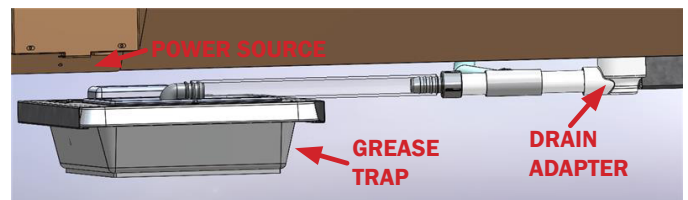


Fig. 46b Optional PVC Drain and Grease Trap

2. Glue together the PVC drain parts (Fig. 47) to the drain hub using only approved PVC primer and cement (Fig. 48). Position the PVC drain to face left toward the location where the grease trap will be installed (Fig. 49).

# CASE INSTALLATION

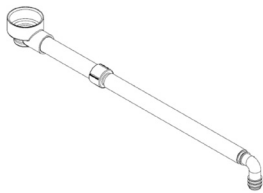


Fig. 47 2-Door PVC Drain



Fig. 48 Approved PVC primer and cement



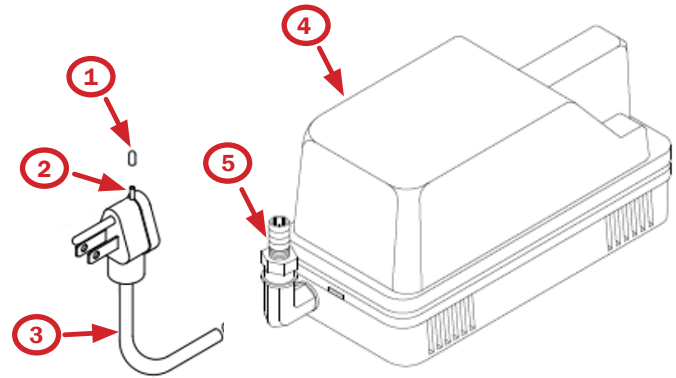
Fig. 49 PVC drain oriented left toward grease trap.

3. Cut a short enough section (5' typically) of tubing to reach from the outlet of the drain to the inlet of the pump. Connect the tubing from the drain outlet nipple to the pump inlet. Attach the 3/8" barbed check valve to the 1/4" N.P.T. elbow, and attach this assembly to the pump's discharge. **BE CAREFUL NOT TO OVER-TIGHTEN.**

Using 3/8" vinyl tubing, run the discharge up to the minimum distance required, being sure not to exceed 10', which is the maximum flow height of the pump.

4. **IMPORTANT: Remove the "Breather Tube Cap" on the pump's power cord.** Plug the power cord into the pump receptacle (Fig. 50).

\*\*The receptacle is Factory-installed on newer case models (Fig. 51).



1	Breather Tube Cap
2	Breather Tube
3	Cord
4	Pump
5	Barb fitting

Fig. 50 Pump components



Fig. 51 Plug pump into pump receptacle

## LEVEL CASES

1. Make sure to perform these steps prior to moving the cases to, and setting them in, their final positions. Rodent-exclusion angles may be required. Install those from the floor to the wall, behind the cases, per the architect's details. Also make sure to consult the plan sets to confirm whether the floor requires any advance preparations if seismic brackets are required.
2. Confirm with the general contractor at new stores, that you have the most current version of the store plans and building dimensions. Then, ask for the points of reference from which you should take dimensions to locate the cases.
3. At new and existing stores, mark the floor where the cases are to be located for the entire lineup using a laser transit (Fig. 35) and chalk lines (preferred method). The lines should coincide with the outside edges of the case feet.



**Fig. 35 Laser transit**

4. Leveling is necessary to ensure proper case alignment and to avoid potential case damage. Locate the highest point on the positioning lines as a reference for determining the proper height of the shim-pack levelers. A laser transit is recommended for precision and requires just one person.
5. Locate the basehorse positions along the chalk lines and then place properly leveled shim packs at each location.

**LINE-UP & INSTALLATION**

**Single Case**

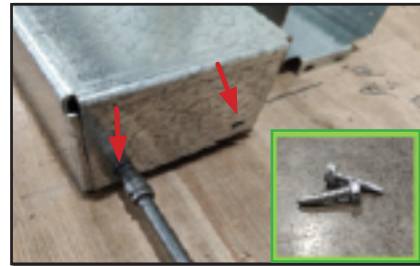
\* The ship-loose junction box will be required at a later step.

1. Move the case into position, leaving a minimum of 2" between the wall and back of case. This space must be unobstructed and is required in order to leave sufficient room for airflow behind the case.
2. Using a "J" bar, raise the case at each base foot and install the base risers. Lower the base risers on to the shim packs. Lift at designated points on the baseframe (see Appendix F).
3. Locate the Hat-sections and the Front Fastening Plates enclosed in the case (Fig. 36).

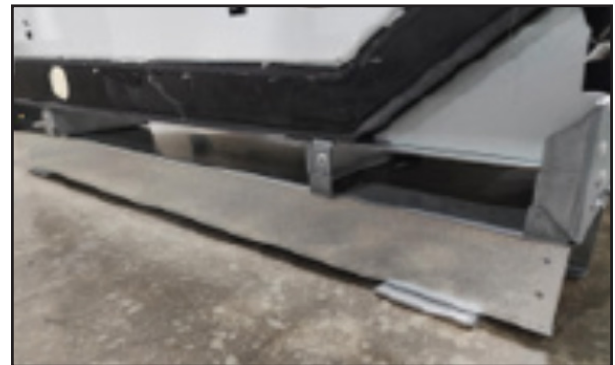


**Fig. 36 Hat-section and front fastening plates**

4. Fasten the rear of each hat-section with 8-size Tek screws (2 nos.) provided (Fig. 37).
5. Align each hat-section from front (at locator lip) at the center of each pair of fork pockets and shim them accordingly.
6. Check the alignment at the front/rear and now place the case over the hat-sections (Fig. 38).



**Fig. 37 Fasten rear of hat-section**



**Fig. 38 Case over hat-sections**

7. Now fasten the locator lip with 8-size Tek screws provided (Fig. 39).



**Fig. 39 Fasten locator lip**

8. Place front fastening plates over side fastening holes; fasten plate with Tek screws on each side (Fig. 40).



**Fig. 40 Fasten front plates to side fastening holes**

9. Once the basehorse is properly placed on the shim packs, check the vertical plumb of the case by placing a bubble level on the shelf standard. Add/remove shim packs as needed. For the horizontal level, repeat this process after placing the bubble level on the front sill.

# CASE INSTALLATION

## Multi-Case

1. Remove shelves and deck pans from the ends of the cases. Also remove any shipping braces and other packing materials that were not removed previously. Keep all other loose items such as kick plates, end kick plates, nose bumper, fascia, etc. for later in the installation process.
2. Remove the return air grill at the case joint. The grill lifts out without fasteners and can be easily removed to gain clear access to the case-to-case joining bolts.
3. Follow the single-case installation instructions for the first case, then position the next case in the line-up approximately 3' away.
4. Apply the foam tape gasket (supplied) and one continuous bead of butyl or silicone sealant against the outer edge of the gasket for medium-temperature cases (Fig. 41).



Fig. 40 Apply foam tape (Medium Temp)

Apply two continuous beads of sealant, one inside and the other outside of the gasket for low-temperature cases (Fig. 42).



Fig. 42 Apply Sealant (Low Temp)

5. Push the second case close to the first case and install the 3.25" riser feet before setting the case on the shim packs (Fig. 43).



Fig. 43 Push second case close to first case

6. Push the cases tightly together, then lightly bolt them together through the six holes (Fig. 44). Tighten all the joining bolts until all margins between the cases are equal.

**NOTE:** Before starting the bolts, the cases must be as tightly together as possible (Fig. 45) and that the bolts should never be used to draw the cases together as doing so will result in damage to the cases.

7. Repeat steps 3–6 of this sequence for all of the remaining cases. Be certain to properly level all of the cases. See **Appendix B** for the steps necessary to install seismic brackets where required by local ordinance.

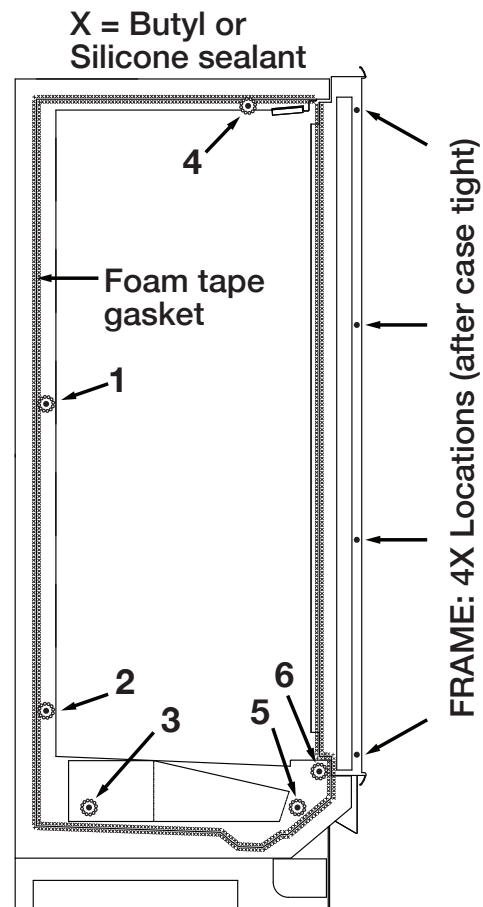


Fig. 44 Bolt holes, foam tape gasket, and sealant

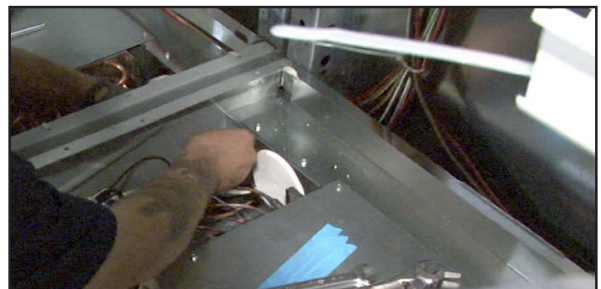


Fig. 45 Tightly align cases before bolting

## ⚠ DANGER

Risk of electrical shock if the cord and strain relief are removed.

### Pump Maintenance and Troubleshooting

Pumps have been designed to provide long, trouble-free service in normal operating conditions. However, if the pump fails to operate, please check the following:

## ⚠ WARNING

Always disconnect from electrical outlet before servicing this pump.

- Is the pump getting electrical power? Check the circuit breaker and try another outlet to be sure.
- Has the intake screen become clogged?
- Are there any kinks or blockages in the discharge tubing?
- Is the impeller broken or jammed with debris?

## ⚠ CAUTION

The cord of this pump contains a small "Breather Tube". This tube is necessary for the proper operation of the pressure switch. Do not allow this tube to become blocked.

## ⚠ WARNING

Do not remove the 4 screws that is holding the diaphragm cover in place. There are no serviceable parts in the switch mechanism, removing or loosening these screws may cause an electrical shock hazard.

### FINAL INSTALL

Electrical connections are made in the electrical junction box located at the top left of the case.

A diagram label on the side of the junction box, on top of the case, indicates exactly where each component is to be secured to the case (Fig. 52). Refer to the diagram before attaching the components.

The electrical junction box is a ship-loose item. Inside the box is a foam egress insert needed in the steps following.

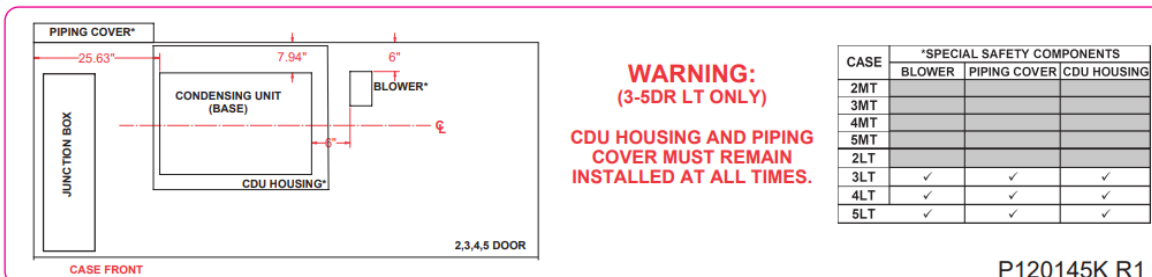


Fig. 52 Electrical junction box diagram label

For any questions or service needs, please contact our Case Division Customer Service Department at 804-614-1457 or [hillphoenix.com/company/contact-us](http://hillphoenix.com/company/contact-us).

1. If egress cover was not removed in "DOORWAY PREP", remove the (2) #8 tek screws holding the egress cover (Fig. 53). **NOTE:** the cover is attached to the case wire harnesses to facilitate their retrieval.
2. Lift harnesses until taught - approximately 6" (Fig. 54).



Fig. 53 Egress cover tek screws

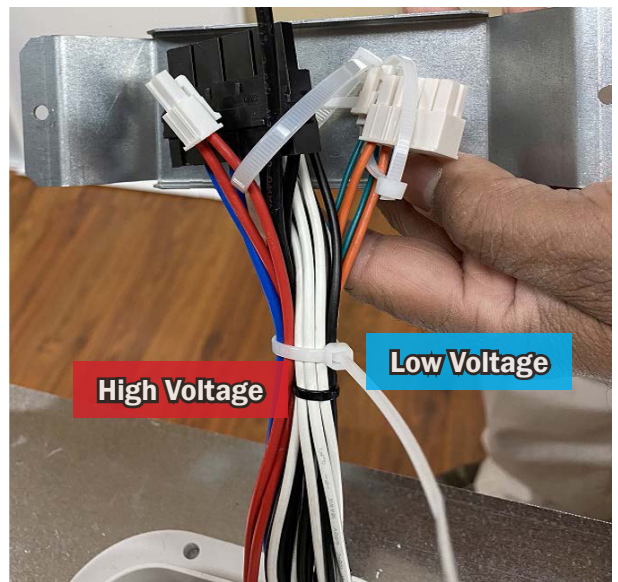


Fig. 54 Lift harness

3. Fit the high voltage harnesses into foam insert's larger hole. Fit low voltage harnesses into the smaller hole (Fig. 55). You may need to wiggle, twist or play with the wires to get them to seat more comfortably in the foam. Take care to evenly press/slide the foam insert into the egress until it bottoms out. The foam will be ~3/4" below top of egress (Fig. 56).

## CASE INSTALLATION

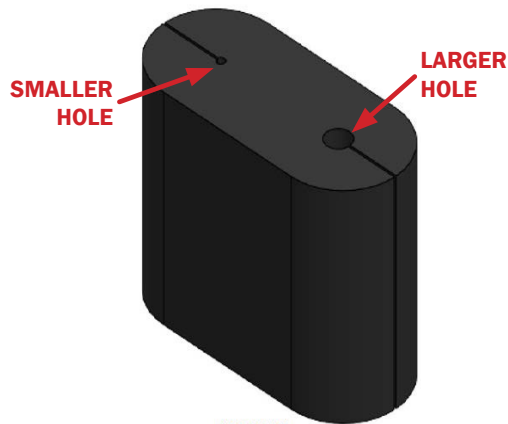


Fig. 55 Foam insert

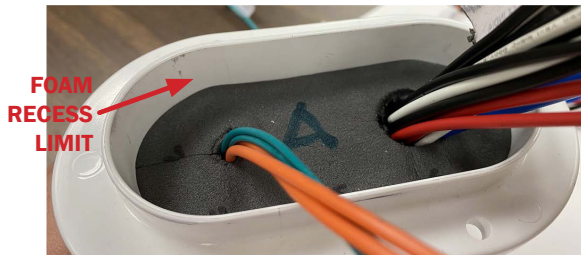


Fig. 56 Foam recess limit: 3/4" below egress opening

### ⚠ CAUTION

Ensure that the foam insert is not recessed more than 3/4" into the egress or it may interfere with air flow in the case.

### ⚠ CAUTION

Straighten and wiggle the wires once the foam is inserted in the egress to help seal around them and to the egress. There must not be any visible path for air to leak out from the case. If there are any concerns about how well the egress is sealed, add permagum or silicone on top of the foam.

4. Remove the egress cover from the harnesses (Fig. 57).

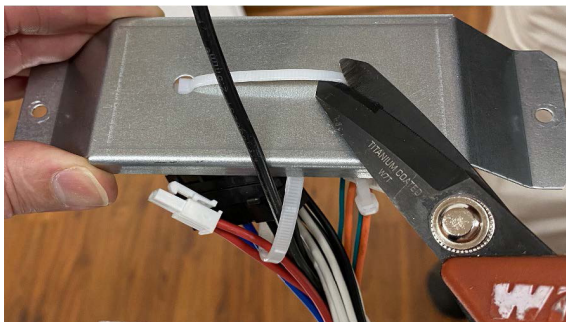


Fig. 57 Remove egress cover

5. Place the junction box on the canopy to the left of the condensing unit, feeding the harnesses through the bottom-rear of the box. (Fig. 58).

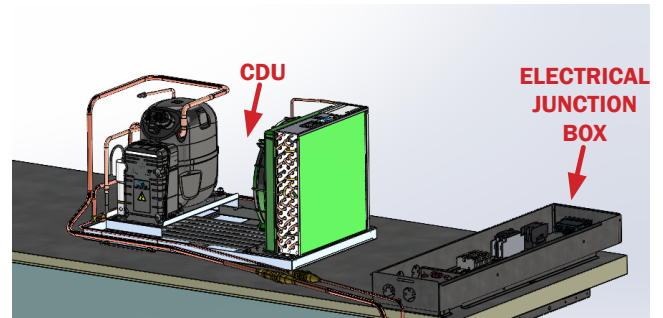


Fig. 58 Rear view of electrical junction box location

6. Plug the unique case harness connectors into their corresponding mates inside of the box (Fig 59).

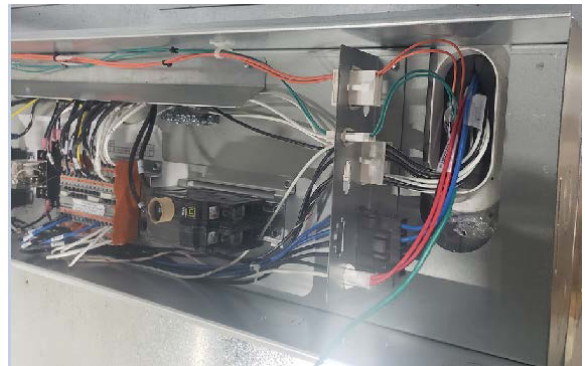


Fig. 59 Connect harnesses to their mates inside junction box

7. Route the green case ground wire along the right-hand (RH) side of the box and in front of the circuit breaker and install ground wire to ground terminal block (Fig. 60).



Fig. 60 Electrical Connections

### ⚠ ATTENTION

For Store, CDU and Condensate Pan wiring: Refer to Appendix C.

- With piping connections reconnected and electrical junction box installed, the condensing unit cover and piping cover can be placed back onto the high charge cases using the screws retained from "DOORWAY PREP" steps 1 and 2 (Fig. 61). Review those steps to ensure covers are fastened properly to complete installation (Fig. 62).  
**NOTE: For low charge cases, see next step.**

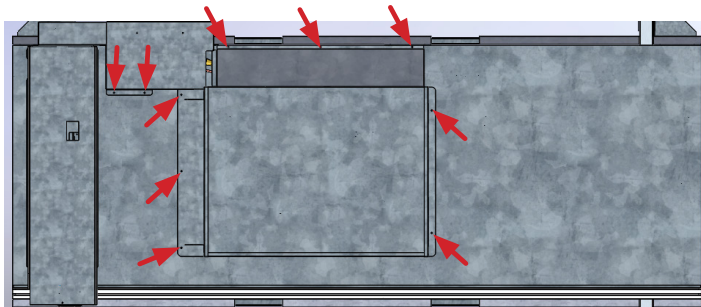


Fig. 61 Location of piping cap fasteners and CDU housing screws (3-5 door cases)

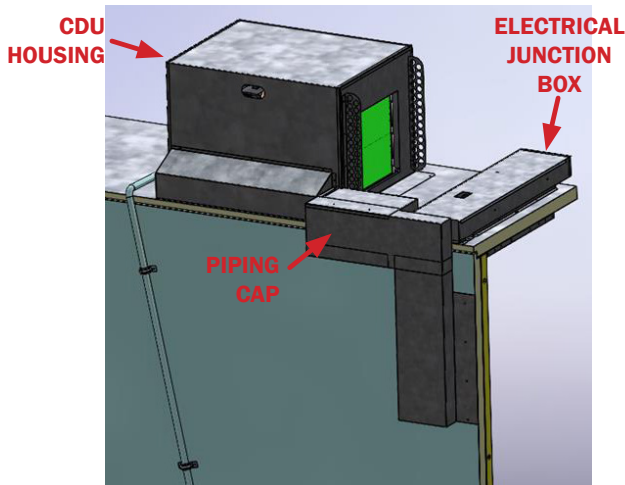


Fig. 62 Rear view of final install (high charge cases)

- With piping connections reconnected and electrical junction box installed on low charge cases, the condensing unit balloon guard can be placed back onto the cases using the screws retained from "DOORWAY PREP" step 3 (Fig. 63).

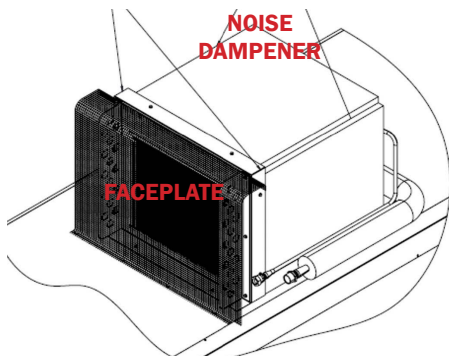


Fig. 63 Low charge housing air-block

**FINAL POSITIONING**

After the installation of all components is complete (Fig. 64), case can be moved into the final location.

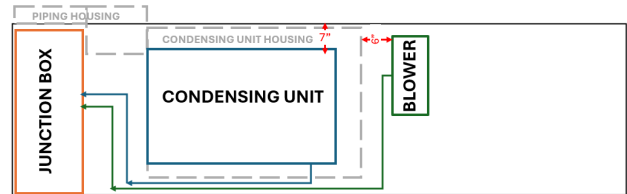


Fig. 64a High Charge Configuration

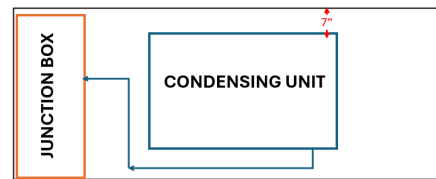


Fig. 64b Low Charge Configuration

## CASE INSTALLATION

### TRIM OUT

1. Seal the interior case-to-case joints with the caulk, and then the acrylic, tape from the ship-loose parts applied over the pipechase seam (Fig. 65). The tape acts as a watershed preventing water from settling in the case joint.

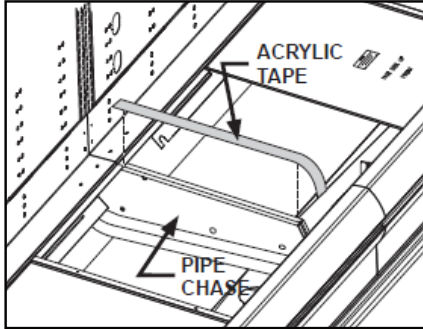


Fig. 65 Sealing the pipe chase

2. Re-install the shelves that were previously removed.
3. Properly align the case front panels as needed, then install the front panel joint trim behind bumper tracks (Fig. 66). Location and style of track and bumper [if ordered] may vary.



Fig. 66 Front panel trim installed behind bumper tracks

### Door Frame Trim Out

The Anthony doors may need be removed when sealing the frame-to-frame joints, or the frame to foamed-partitions. To remove the doors:

1. Disconnect hold-open assembly from door frame (Fig 67).



Fig. 67 Disconnect hold-open assembly

2. Release the tension from the closing mechanism at the bottom of the door using a flat-head screwdriver, turning until the screw is free of tension (Fig. 68).

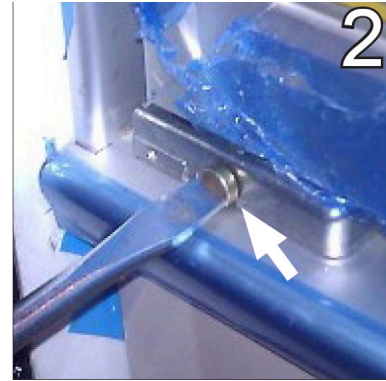


Fig. 68 Release tension from closing mechanism

3. Depress the spring clip at the top of the door (Fig. 69). Pull the top of the door free from the receptacle, then lift door free from the lower hinge plate. Set the door aside.

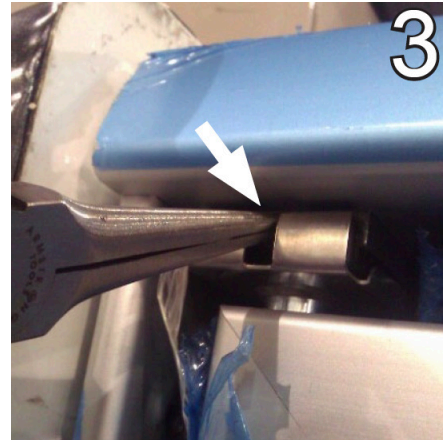


Fig. 69 Depress spring clip at top of door

4. Use a clamp to close the gap between the frame end and the foam partition, which compresses the sealant applied earlier (Fig. 70).

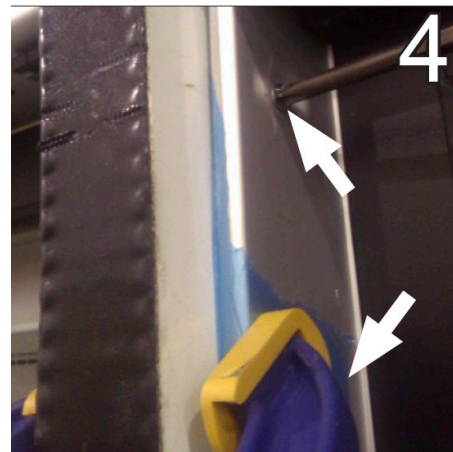
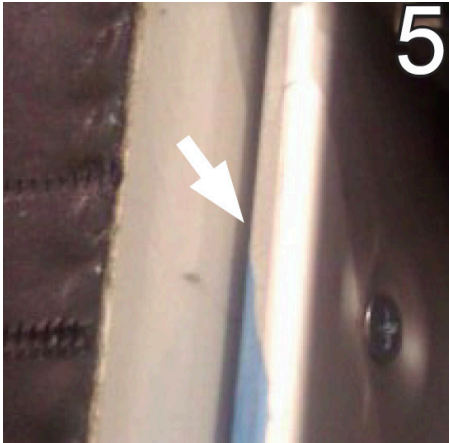


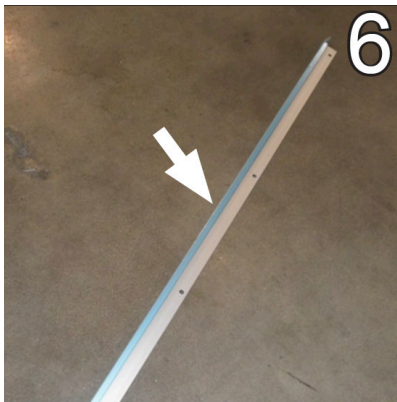
Fig. 70 Clamp to close gap between partition and frame

5. Tightly secure the frame to the partition using flat-head self-tapping screws (#6), included with the ship-loose parts. There should be no gap between the frame and foamed-partition when done (Fig. 71).



**Fig. 71 Secure frame to partition**

6. For case-to-case trim-out (no foam partition), carefully push the provided T-bar (Fig. 72) between the frames. Secure with the provided T-bolts.



**Fig. 72 Secure frame to partition**

7. Re-install the door by reversing steps 1-3.
8. Install the door frame joint trim with sex bolts (included with the ship-loose parts) that bolt through the door frames (Fig. 73), tightening the bolts compressing the sealant that was applied earlier (on page 14).



**Fig. 73 Door frame trim installed**

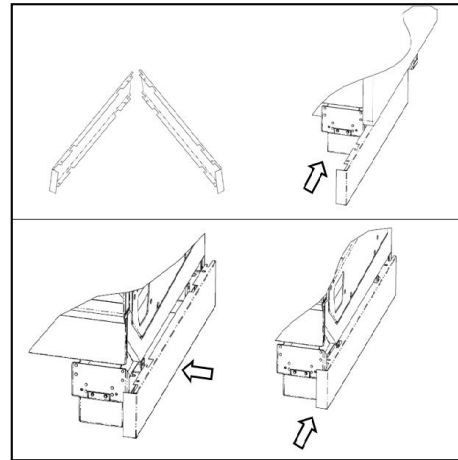
## Kickplate Trim Out

1. Install the end kickplates before the front kickplate (Fig. 74). The same end kickplate piece is used on both the left and right ends of the lineup or single cases.



**Fig. 74 End kickplate installation**

2. Slide the end kickplate front to rear, under the end of the case (Fig. 75). When the front flange is about  $\frac{9}{16}$ " from the base foot, slide it (the front flange) the rest of the way under the case also – then slide the whole kickplate the final  $\frac{9}{16}$ " rearward so that the metal tabs nest behind the case base feet (included with the ship-loose parts). The front flange of the end kick-plate is held in place when the front kick-plate is installed in the next step.



**Fig. 75 End view of front kickplate install**

3. Install the front kickplate by inserting its top flange behind the front panel of the case (Fig. 76) and then rotating it down to the floor.



**Fig. 76 Insert kickplate's top flange behind front panel**

## CASE INSTALLATION

- Secure the kickplate with color-matched screws through pre-punched slots to the base frame (Fig. 77), completing the kickplate install (Fig. 78).



**Fig. 77 Secure the kickplate to base frame**



**Fig. 78 Case lineup with kickplates installed**

### Top Fascia Trim Out

- Align the front fascia to the curved flange of the door frame (Fig. 79). Then secure the bottom edge of the front fascia to the case through the pre-punched screw holes (Fig. 80).



**Fig. 79 Align the front fascia to the curved flange of door**



**Fig. 80 Secure front fascia**

- Align the junction box's Carel controller display with the pre-punched cutout in the front fascia (Fig. 81). With box parallel to side of the case, egress flange will protrude the left-hand (LH) side of the junction box.



**Fig. 81 Align pre-punched cutout in front fascia**

- Secure the electrical box to the case body using (4) #8 tek screws (Fig. 82).



**Fig. 82 Secure electrical junction box**

- Attach the two-part end panels (extended the nested back section of the panel to the wall behind the cases and secure the front and back sections to each other) to the front fascia using pre-punched screw holes. Then secure end panels to the case body.
- Attach the support struts to the back of the panels. Install the support brackets near the rear wall of the case to provide room to remove the junction box cover and to avoid the CDU suction line on 2 door cases (Fig. 83).



**Fig. 83 Extend to wall and secure**

6. Install the fascia support brackets by securing end panels to the front fascia (Fig. 84).



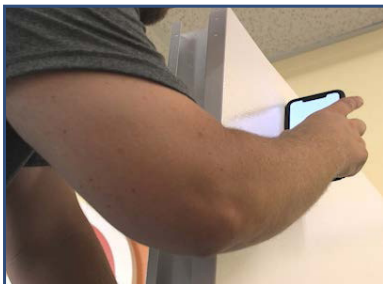
**Fig. 84 Secure end panel to front fascia**

7. **\*IMPORTANT:** Make sure to leave approximately 1/2" between the strut and the junction box cover to allow the box to open (Fig. 85). The bracket can be installed flange-up to gain distance.



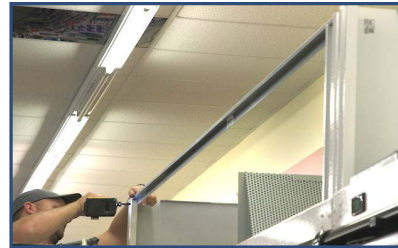
**Fig. 85 Front view of support bracket and junction box view**

8. Check the panel's vertical alignment (Fig. 86), adjust if necessary.



**Fig. 86 Check vertical alignment**

9. Attach the unpainted frame rail between adjacent panels (Fig. 87).



**Fig. 87 Install unpainted frame rail**

10. Mount the store signage to the fascia framework (Fig.88).



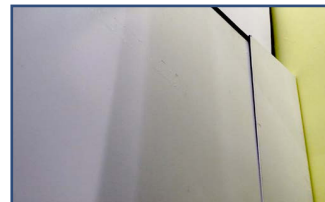
**Fig. 88 Mount store signage to fascia**

11. Install the front panel joint and door frame trim (Fig. 89).



**Fig. 89 Install frame trim between doors**

12. Install the top and bottom end-to-wall close-off panels for the opposite ends of the lineup (Fig. 90).



**Fig. 90a Top close-off panel**



**Fig. 90b Bottom close-off panel**

## START UP & PERFORMANCE

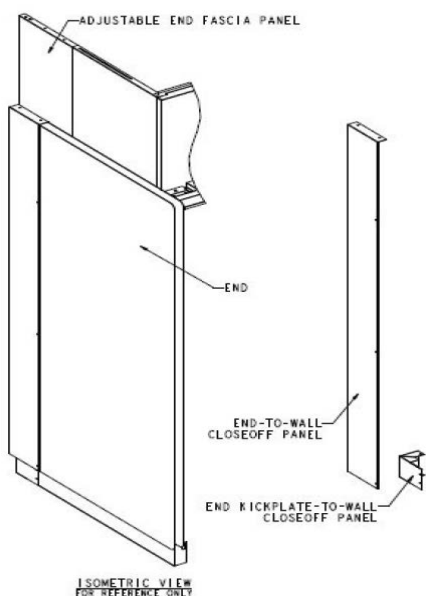


Fig. 90c Top and bottom close-off panels

### ⚠ ATTENTION

Refer to **Appendix E** for more information on installing the fascia framework.

13. The close-off panel's hemmed top rests on top of the case's insulated end panel. Slide the close-off panel (Fig. 91) back to close any gaps to the wall behind the case. Fasten it to the case with #8 Tech screws through the pre-drilled holes in the panel.



Fig. 91 Bottom end-to-wall close-off panel

### START-UP & PERFORMANCE CHECKS

When installation has been completed, the cases should be started up following these steps:

1. Confirm that incoming power is properly connected and then switch ON the electrical box breaker on at top of the case to turn on the case (Fig. 92).



Fig. 92 Switch location on junction box

2. Check that the condensing unit fan is running and that the compressor kicks on.
3. Check that the remote display at the top of the case confirms the compressor is running, that no faults are displaying, and that the current discharge air temperature is dropping (Fig. 93).

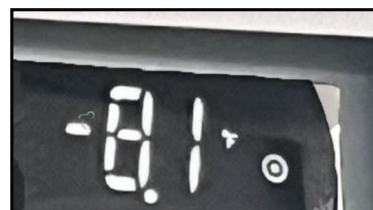


Fig. 93 Remote Display

4. Check the evaporator fans are on and running properly (in the right direction) by removing the wire racks, return air grill and lift the deck pans (Fig. 94).



Fig. 94 Running evaporator fans

5. Confirm the pump is operating by pouring a container of water, large enough to fill the pump reservoir, down the case drain under the deck pans (Fig. 95).

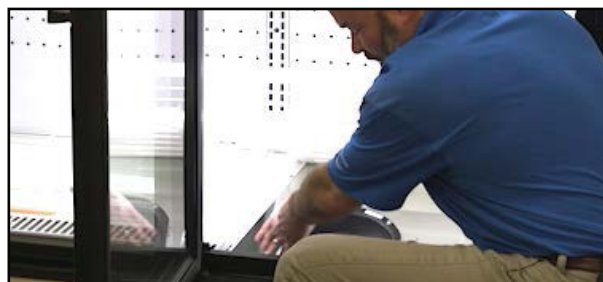


Fig. 95 Check pump operation

6. Check the remote display temperature reading one more time to confirm the case is pulling down to temperature after performing the other checks.

### ⚠ CAUTION

*Be careful to not touch the heating element which can cause burns.*

**REFRIGERATION**

The condensing unit is located on top of the case for easy access (Fig. 96). Refrigerant piping runs down the rear of the case to and from the coil (evaporator) inside of the case. The expansion valve and other controls, which are located on the left-hand side of the case, are accessed by lifting the left-hand deck pans (it is not necessary to lift the fan plenum shroud).

Before operating the case, be certain to remove any shipping blocks that protect the refrigeration lines during shipping. If it becomes necessary to penetrate the case tank in any area, be certain to seal any open gaps afterwards with canned-foam sealant and white RTV (Room Temp. Vulcanizing Silicone).

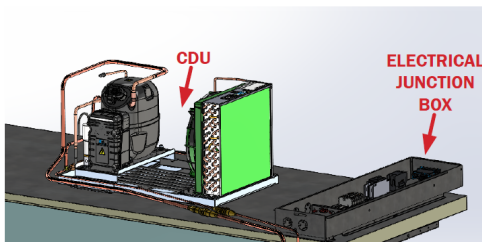


Fig. 96 CDU location

**⚠ ATTENTION**

Connections are illustrated in the dimensional drawing in Appendix A.

**PLUMBING**

The drain outlet is specially molded out of PVC material and is located at the front-center of the case for convenient access. The “P” trap that is furnished with the case is constructed of schedule 40 PVC pipe (Fig. 97). Case run-off (from condensation and other sources) is drained through the “P” trap by plastic tubing to the pump underneath the case. The pump is connected by more plastic tubing to the condensate/evaporative pan on top of the case.

For more details on case plumbing, see the Case Installation Case Prep section.

**NOTE:** Hillphoenix offers a version of the case that is designed for use with floor drains where required by local ordinance.

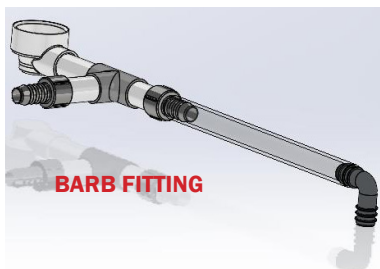


Fig. 97a High Charge Adapter

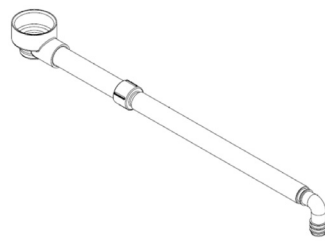


Fig. 97b. Low Charge Adapter

With the kickplate shipped loose (uninstalled), the drain line area under the case is readily accessible during installation. If the kickplate for some reason has been installed, it easy to remove. Simply remove the kickplate joint trim, then unscrew the upper and lower kickplates from the kickplate supports and remove (see Trim Out instructions on pages 19-23).

Care should be taken to ensure that all connections are water-tight and sealed with the appropriate PVC or ABS cement (see page 15).

**ELECTRICAL**

Electrical connections are made in the electrical junction box located at the top left of the case (Fig. 98). The cases use a Carel Case Controller. Lighting for the cases is pre-installed during manufacturing. Lighting can be in either two ways: through motion sensors on the case or the lighting can be programmed within the controller using timers set per the appropriate time zone. Lighting instructions can be found on page 25. The Anthony door/frame units are factory-installed and have anti-sweat control through the embedded controller in the standard configuration of the case. For any questions or service needs, please contact our Case Division Customer Service Department at 804-614-1457 or [www.hillphoenix.com/company/contact-us/](http://www.hillphoenix.com/company/contact-us/)

For more detailed electrical wiring information, see **Appendix C**. For more detailed information on the Carel Case Controller and setpoints, see **Appendix D**.



Fig. 98 Electrical Junction Box

**⚠ DANGER**

Case requires 4-wire power from the store. Neutral wire must be connected prior to starting case or else damage may occur.

**⚠ CAUTION**

If brazing is necessary, place wet rags around the area to avoid tank damage.

**⚠ CAUTION**

Be certain that all piping and electrical connections comply with local codes.

**⚠ CAUTION**

This case must be powered only in electrical installations with ground fault circuit interrupter (GFCI) circuit breakers or residual current device (RCD).

## CASE DETAILS

### MPXzero Lighting Schedule Setup Guide

1. Download the Carel phone application **Applica**.
2. Open **Applica** on your device.
3. Select **Bluetooth** and connect to the desired controller.

*Tip: Hold the device in close proximity to the desired controller to ensure the intended case is being edited.*

4. When prompted for a profile, select **Manufacturer**.
5. Enter **44** as the password when prompted.

**Note: If “44” is not accepted, leave the password field blank.**

6. Open the menu using the hamburger icon (☰) in the top left corner.
7. Select **Parameter List** from the menu options.

8. Select **DAY/NIGHT** from the parameter options at the top.

**Note: There are 8 total time bands available. Start times are labeled as “tSx” and “tEx” are labeled as end times, where “x” ranges from 1 to 8.**

9. For each time band, choose the “-d” (**days**) option and select the **All Days** option.

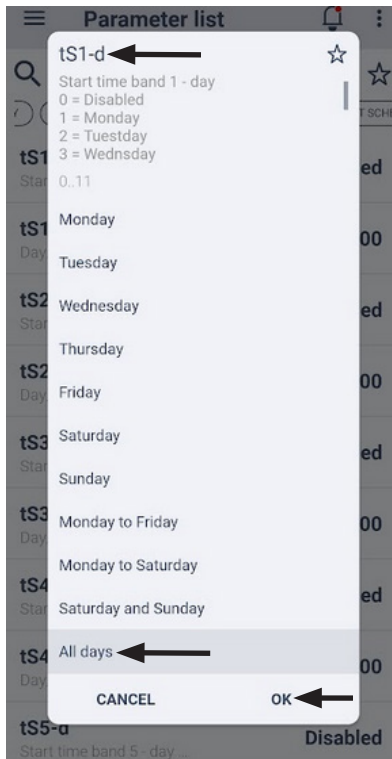


Fig. 99 Time band details

10. To set the lighting start times, choose the “-time” option for each **tSx** parameter and enter the desired start time for lighting.

11. To set the lighting end times, choose the “-time” option for each **tEx** parameter and enter the desired end time for lighting.

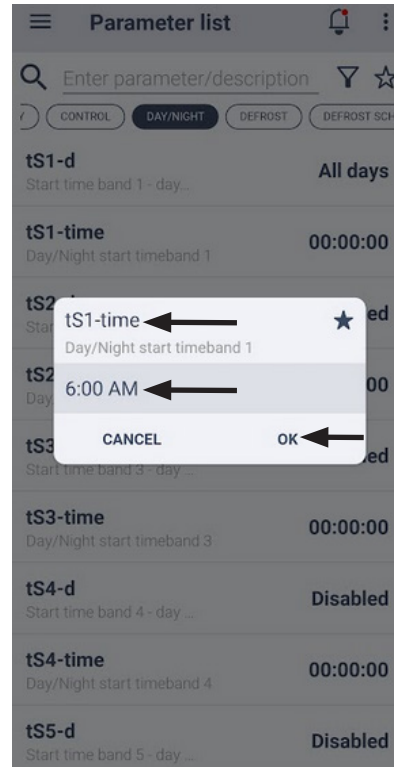


Fig. 100 Day start timeband example

12. When finished, open the menu (☰) and select **Disconnect**.

13. Select **Yes** to disconnect.

Before powering-up the case, and then when it's started, be certain that all of the steps listed below have been completed to ensure proper case functionality, safety, and compliance with warranty terms.

Have you:

- Thoroughly examined the case for shipping damage? (see pg. 6)
- Checked the vertical plumb and the horizontal level of the case? (see pg. 14)
- Applied the foam tape gasket and sealant to the ends of one of each pair of adjoining cases? (see pg. 14)
- Sealed the case-to-case joints by applying caulk and acrylic tape to the pipe-chase seams? (see pg. 21)
- Confirmed that incoming power is properly connected? (see pg. 25)
- Checked that the condensing unit fan is running and that the compressor kicks on when the case is turned on? (see pg. 25)
- Checked that the remote display at the top of the case confirms the compressor is running, that no faults are displaying and that the current discharge air temperature is dropping? (see pg. 25)
- Checked that the evaporator fans are ON and running properly (see pg. 25)
- Confirm the pump is operating (see pg. 25)
- Removed the shipping blocks from the refrigeration lines? (see pg. 26)

# AIRFLOW & DEFROST

## AIR FLOW & PRODUCT LOAD

Do not overload the product in the case so that it blocks the air flow pattern—doing so will result in reduced performance and the inability of the case to maintain proper temperature, particularly when the discharge honeycomb and return air grille are covered. Make sure to keep products within the load limit line (Fig. 101).

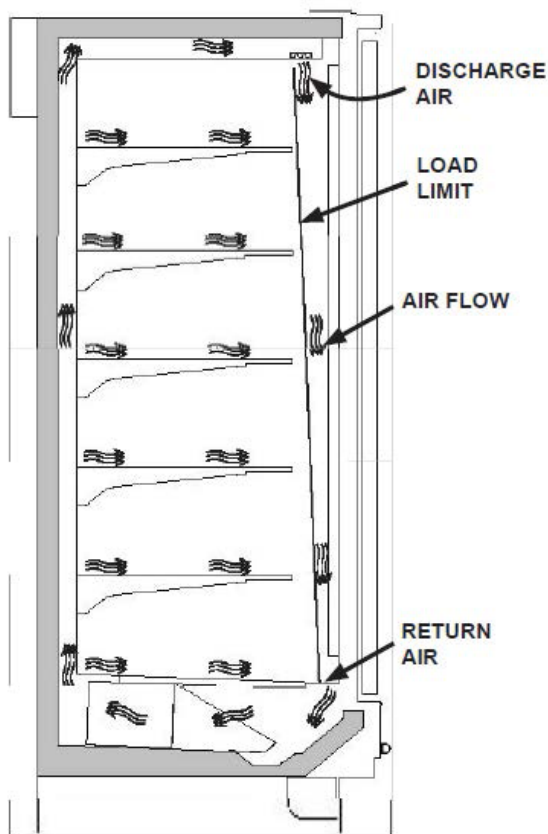


Fig. 101 Airflow, probe, and sensor locations

## DEFROST & TEMPERATURE CONTROLS

The primary components used for the defrost cycle are the various defrost termination sensors, which work to terminate the defrost cycle in the case.

JNRBHSAs utilize Off-Time defrost. The defrost termination probe is housed at the rear wall, behind the lower rear baffle. The discharge air probe monitors the temperature of the discharge air and may be used as the defrost termination sensor. The probe can generally be found behind the rear baffle, in the upper baffle, or in front of the honeycomb.

NOTE: If the discharge air probe is used for defrost termination, none of the termination sensors listed earlier will be installed in the case.

JNRZHSAs utilize hot gas defrost. The defrost termination probe is mounted on the suction line, under insulating tape, near the vertical suction header at left end of the coil (Fig. 102). The discharge air probe monitors the temperature of the discharge air and is found behind the plug button in the upper flue panel.



Fig. 102 LT defrost termination probe sensor location

For more detailed information on suggested defrost times and settings, see Appendix A. Further adjustment may be required depending on store conditions.

## DETERMINING SUPERHEAT

To identify proper superheat settings, perform the following steps:

1. Obtain the suction pressure from the access port. Obtain the suction line temperature from the area near the TXV bulb at the outlet of the evaporator coil (Fig. 103).
2. Using the suction pressure reading, convert pressure to temperature.
3. Finally, subtract the converted temperature reading from the actual temperature reading. The resulting number is the superheat setting. Once this has been determined, adjust the TXV as needed to obtain the proper setting.

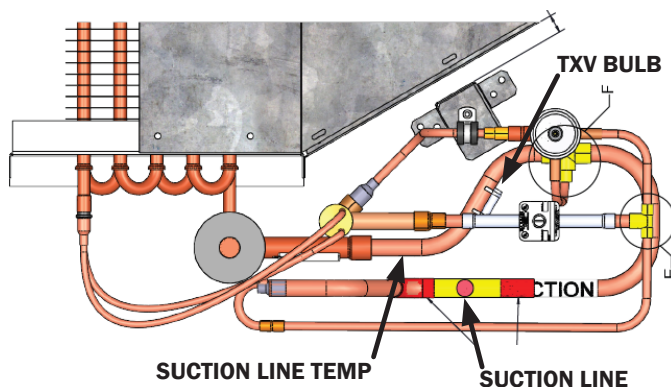


Fig. 103 Obtain pressure/temperature readings from these points

## CLEANING PROCEDURES

A periodic cleaning schedule should be established to maintain proper sanitation, insure maximum operating efficiency, and avoid the corrosive effect of food fluids on metal parts. Hillphoenix recommends cleaning once a week:

- Be certain that all electricity to the case is turned off before servicing or cleaning to avoid electrical shock. In some cases, more than one switch may need to be turned off to completely de-energize the case.
- All surfaces pitch downward to a drain trough, funneling liquids and other debris to the waste outlet. Check the waste outlet before starting the cleaning process to insure it is unclogged. Avoid introducing water faster than the case drain can carry it away.
- Access the coil for cleaning and maintenance by removing (2) screws at the ends of the plenums and gently sliding the plenum assembly forward taking care to not damage any of the refrigeration piping or electrical components beneath the plenum (Fig. 104).



**Fig. 104 Coil & single-piece fan plenum**

- Clean the lights only when lights are shut off in the case. Wipe them down with a soft, damp cloth. Avoid using harsh or abrasive cleaners as they may damage the lights. Be certain that the lights are completely dry before re-energizing.
- If any potentially harmful cleaners are used, be certain to provide a temporary separator (e.g., cardboard, plastic wrap, etc.) between those cases that are being cleaned and those that may still contain product.
- Avoid spraying cleaning solutions directly on electrical connections.
- Allow cases to be turned off long enough to clean any frost or ice from coil and pans.
- Remove the kickplate and clean underneath the case with a broom and a long-handled mop. Use warm water and a

disinfecting cleaning solution when cleaning underneath the cases.

### ⚠ DANGER

#### SHOCK HAZARD

Always disconnect power to case when servicing or cleaning. Failure to do so may result in injury or death.

### ⚠ CAUTION

Exercise extreme caution when working in a case with the coil cover removed. The coil contains many sharp edges that can result in severe cuts to the hands and arms.

## FANS

Hillphoenix door cases feature electronic commutated fan motor assemblies. The fans have a factory-set blade pitch and a pre-configured RPM specific to each model.

Fan assemblies may be changed with an simple two-step process without lifting up the plenum, thereby avoiding having to unload the entire product display to change the fan assembly:

1. Unplug the fan motor (Fig. 105) from the receptacle on the exterior of the fan plenum. Push the power cord back through the plenum opening.
2. Remove fasteners, then lift out the entire fan basket. (Reverse procedure when re-installing the fan assembly.)



**Fig. 105 Fan basket**

### ⚠ CAUTION

The power cord must be pushed back through the plenum opening before removing the fan basket. Failure to do so may result in damage to the power cord.

### ⚠ IMPORTANT

When re-installing the fan in field; orient the fan cord to the 7 o'clock position. Pull any excess cord slack forward and tie tightly.

# SAFETY DEVICES & SERVICE

## SAFETY DEVICES

### **WARNING**

**It is absolutely forbidden for the user to tamper with safety devices.** Before using the refrigerated case check that mechanical safety covers are properly in place. Any tampering shall render the warranty null and void and exonerate Hillphoenix from any liability with regard to users of the refrigerated case.

Only maintenance personnel may carry out maintenance tasks involving safety devices. These tasks are listed below:

SAFETY DEVICE	SCOPE OF INTERVENTION	ACTION
Incorporated over-pressure cut-out	On incorporated condenser unit	Cuts the electrical power of the compressor if the pressure of the refrigerant rises above the safety limits.
Ignition proof zone established around electrical junction box	On incorporated Condensing unit Condensor Fan	Prevents leak access to electrical components. Fans operate 100% of the times.
Case Internal leak mitigation system	External Blower system connected to the Tank drain adapter	Facilitates evacuation and dissipation of leaked charge during defrost cycle
Safety Housing (on cases with greater than 150gm charge) to be removed with tools for servicing	Sheet metal housing on Condensing unit	Prevents access to and protects piping in the Condensing Unit
Piping Cover (on cases with greater than 150gm charge) to be removed with tools for servicing	Sheet metal housing on external Copper piping	Prevents access to and protects external piping at the rear of the case

## DESCRIPTION OF RESIDUAL DANGERS AND RISK

### Residual Dangers

Dangers that have not been reduced/eliminated with the safety measures adopted on the refrigerated case can nevertheless be reduced/eliminated as long as users apply proper managerial practices.

- Ensure that all safety warning and labels are always in good condition; inspect them periodically and have them replaced whenever necessary.
- Do not install any spare parts that are not identical to the originals or of equivalent performance.
- Do not carry out any modifications or structural work without approval from Hillphoenix or a qualified field service technician.

- Should the refrigerated case be dented, inspect the structure visually or have qualified personnel carry out an inspection.

After a long period of disuse have a qualified field service technician carry out an inspection of the case to check that it is in good condition and working properly.

### Residual Risks

While the refrigerated case has been designed to ensure maximum safety, there nevertheless remain some residual risks. Hillphoenix has identified the main **dangers and residual risks for users and maintenance personnel** as follows in the “Scheduled Maintenance Table” on the next page.

## REFRIGERANT

This piece of equipment uses a R-290 Refrigeration system. This equipment has been clearly marked on the serial tag the type of refrigerant that is being used. There is also a warning label stating that the unit contains R-290 refrigerant.

No smoking or open flames when servicing this equipment. If needed, use a Class B (CO2 or dry powder) type fire extinguisher.

Only an authorized service technician, certified in R-290 system should service this equipment.

### **DANGER**

#### **SHOCK HAZARD**

Always disconnect power to case when servicing. Failure to do so may result in injury or death.

Use an R290 approved fan for constant ventilation while working.

- If an R290 approved fan is not available, make sure fan is at least 10’ away from cabinet.
- Remove at least two panels from the base to allow air flow through the unit.
- Point the fan towards the bottom of the work area as R290 is heavier than air.

The work area must be free from sources of ignition such as open flames and sparking electrical devices, like light switches. Keep a 10’ perimeter around the case of clearance.

The propane gas used in the unit has no odor. The lack of smell does not indicate a lack of escaped gas.

Recommend posting a “Flammable Refrigerant” placard in the area prior to servicing.

## MANIFOLD SET

A R-134a manifold set can be used for servicing this equipment.

## REFRIGERANT RECOVERY

Follow all national and local regulations for R-290 refrigerant recovery.

**SCHEDULED MAINTENANCE TABLE**

<b>DESCRIPTION OF RESIDUAL RISK</b>	<b>CAUSE</b>	<b>SAFETY MEASURES</b>
Danger of falls in area surrounding the cabinet	Presence of: stairs, columns etc. and/or slippery floors and objects and/or work tools	Mark out the relevant zones and highlight them with warning signs and symbols (e.g. yellow/black striped marker tape on stairs etc.) that are visible during both routine use and maintenance.
Danger of objects accidentally falling	Haphazard storage of tools/objects.	Use tool boxes in work areas. Ensure personnel are trained.
Danger of injury to hands, arms, legs and head	During cleaning and maintenance there may be objects or parts of the cabinet protruding from the case itself (e.g. glass covers open during cleaning)	Mark out the work area with appropriate barriers. Always use the recommended personal safety devices.
Risk of refrigerating gas leaks	Accidental damage to pipes	Immediate shutdown of case operation. Disconnect electrical power supply. Contact a service technician.

**LEAKING CHECKING AND REPAIR**

Leak check an R-290 system the same way you would an R-134a or R-404a system with the following exceptions.

1. Do not use a Halide leak detector on a R-290 system.
2. Electronic leak detector must be designated specifically for combustible gas.

A quality combustible gas leak detector is mandatory for hydrocarbon service work. Leak detector should be placed near the bottom of the cabinet, as R290 is heavier than air.

When repairing a leak, it is recommended using oxygen free dry nitrogen with a trace gas not exceeding 200PSI.

When accessing an R-290 system, proper charge is to be weighed into the system and the system is to be leak checked afterwards.

The R-290 equipment must have red process tubes and other devices through which the refrigerant is serviced, such as any service port. This color marking must remain on the equipment. If marking is removed, it must be replaced and extended at least 2.5 centimeters (1") from the compressor.

**⚠ CAUTION**

Component parts shall be replaced with like components. Service work shall be done by factory authorized service personnel, so as to minimize the risk of possible ignition due to incorrect parts or improper service.

**CHARGING**

Follow the charge amount specified on the data tag. It is recommended to use the shortest hoses possible to prevent undercharging.

- Component parts shall be replaced with like components. Service work shall be done by factory authorized service personnel, so as to minimize the risk of possible ignition due to incorrect parts or improper service.
- Ensure the system is sealed and leak checked
- Evacuate system to a minimum 500 microns
- Weigh in correct charge
- Leak check the system again
- Bleed the refrigerant from the high side hose to the low side hose
- Disconnect the hoses
- Remove line taps

**CHARGING PORTS**

Schrader port locations across the case are red marked to highlight them as Charging ports per regulations (Fig. 104).

**⚠ WARNING**

Use Caps with o-rings on Schrader Valves, post service.



Fig. 106 Schrader port locations

### DANGER

#### FLAMMABLE

DANGER - Risk of Fire or Explosion. Flammable Refrigerant Used. Do Not Use Mechanical Devices To Defrost Refrigerator. Do Not Puncture Refrigerant Tubing.



### CAUTION

**It is highly recommended that a technician servicing a case with HC refrigerant is aware of safety considerations and maintenance procedures on how to safely handle flammable refrigerants.**

## DE-ICING EVENTS

Depending on the severity of the icing event, there may not be enough capacity in the pan to accommodate all of the water. The recommended procedure is for the service technician to:

1. carry a 3/8" vinyl tube
2. connect this tube to the outlet of the pump
3. pump excess water to a drain or into a 5 gallon bucket.

If the technician does not have this hose on-hand, then they can use the one attached to the pump by disconnecting it at the top of the case and reinstalling it when finished.

# Hillphoenix®

a **DOVER** company

Contact the Service Parts Department at:

**1-833-372-7871**

or

**orderparts@doverfoodretail.com**

Provide the following information about the part you are ordering:

- Model number and serial number\* of the case for which the part is intended.
- Length of the part (if applicable).
- Color of part (if painted) or color of polymer part.
- Whether part is for left or right-hand application.
- Quantity

\*Data tag is located on the left end exterior panel or top interior of the case.

If the parts are to be returned for credit, contact the Parts Department. Do not send parts without authorization.



## APPENDIX

A .....	Technical Reference Sheet
B .....	Seismic Brackets
C .....	Electrical Wiring
D .....	Controllers and Setpoints
E .....	Fascia Frame
F .....	Case Lifting Locations

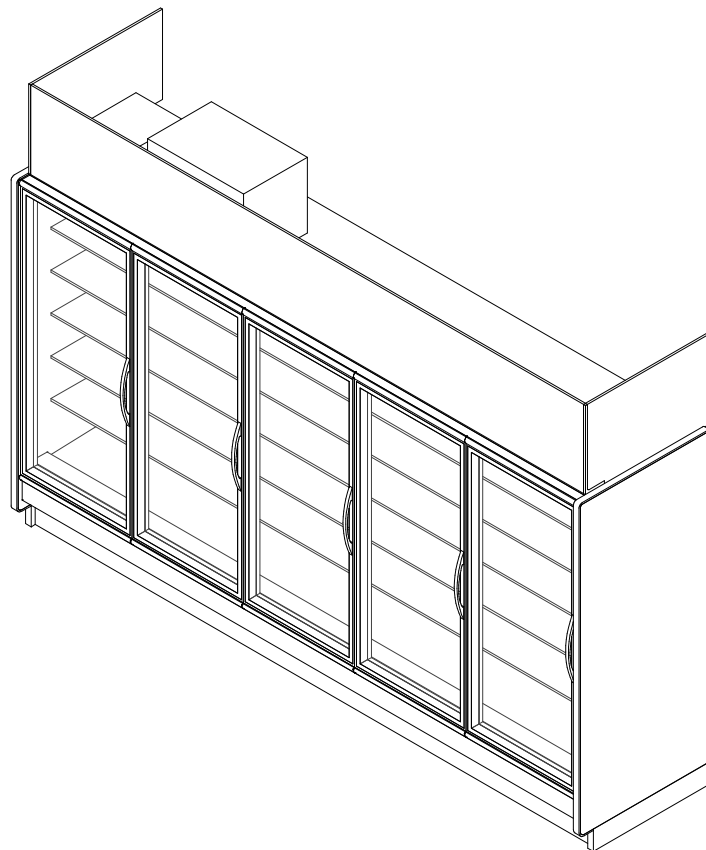
# A1: TECHNICAL REFERENCE SHEET

## JNRBHSA

2, 3, 4 & 5 Door / 6', 8', 12' High Narrow Reach-In Self Contained Merchandiser  
Beverage/Bakery/Dairy/Cut Produce/Deli

### GENERAL NOTES:

- "---" indicates that the feature is not an option with this case model and/or the data is not available at this time.
- Light controls - occupancy sensors are required.
- Option 1: OEM Provided: OEM anti-condensate and lighting controls (on/off) are standard unless otherwise specified.
- Option 2: End User Provided: Light controls should be based on occupancy sensors.
- WARNING: R-290 flammable refrigerant in use. Read the installation, operating and maintenance instructions thoroughly before installing or servicing this equipment.



SHIPPING WEIGHT	
Case	Weight
JNRBHSA	---



COMPONENT  
ALL MEASUREMENTS ARE TAKEN PER ASHRAE-72 SPECIFICATIONS. HILLPHOENIX REFRIGERATED DISPLAY CASES FOR SALE IN THE UNITED STATES MEET OR EXCEED DEPARTMENT OF ENERGY 2017 REQUIREMENTS.

### JNRBHSA

Rev. Date	Rev. #	Rev. Title
11-10-25	5	DATA UPDATE
07-16-25	4	DATA UPDATE



## A2: TECHNICAL REFERENCE SHEET

# JNRBHSA

2, 3, 4 & 5 Door / 6', 8', 12' High Narrow Reach-In Self Contained Merchandiser  
Beverage/Bakery/Dairy/Cut Produce/Deli



SYSTEM REQUIREMENT										
Case Length	Volts	Wiring Type	Phase	Frequency (Hz)	Optional Factory Installed Plug		MCA	MOP	24hr Energy Usage (kWh)	Heated Dissipated to Room (BTUH)
					Size	Amps				
2 Door	120	2 Wire + Gnd	1	60	NEMA 5-15P/L5-15P	6.95	8.1	15.0	6.4	1501.3
3 Door	120	2 Wire + Gnd	1	60	NEMA 5-15P/L5-15P	7.70	8.9	15.0	9.6	1716.2
4 Door	120	2 Wire + Gnd	1	60	NEMA 5-15P/L5-15P	9.46	11.2	15.0	11.6	1781.1
5 Door	120	2 Wire + Gnd	1	60	NEMA 5-20P/L5-20P	12.88	15.8	20.0	15.3	2900.2
6'	120	2 Wire + Gnd	1	60	NEMA 5-15P/L5-15P	7.57	8.4	15.0	8.8	---
8'	120	2 Wire + Gnd	1	60	NEMA 5-15P/L5-15P	8.61	9.7	15.0	10.6	---
12'	120	2 Wire + Gnd	1	60	NEMA 5-20P/L5-20P	12.58	14.4	20.0	12.9	---

ELECTRICAL DATA			
Case Length	Fans Per Case	Evaporator Fans	
		120 Volts	
		Amps	Watts
2 Door	1	0.42	34
3 Door	2	0.84	68
4 Door	3	1.26	102
5 Door	3	1.26	102
6'	2	0.84	68
8'	2	0.84	68
12'	3	1.26	102

LIGHTING DATA					
Case Length	Door Size	OP7 Single Swing		OP7 French Swing	
		120 Volts		120 Volts	
		Amps	Watts	Amps	Watts
2 Door	30"	0.28	33.0	---	---
3 Door	30"	0.41	49.2	---	---
4 Door	30"	0.55	65.4	---	---
5 Door	30"	0.68	81.6	---	---
6'	24"	---	---	0.44	52.3
8'	24"	---	---	0.44	52.3
12'	24"	---	---	0.64	76.6

ANTI CONDENSATE DATA					
Case Length	Door Size	101 Frames		Vista Frames	
		Un Heated Doors		Un Heated Doors	
		ELMD, I90		I60	
		120 Volts		120 Volts	
		Amps	Watts	Amps	Watts
2 Door	30"	0.36	43	0.36	43
3 Door	30"	0.55	66	0.55	66
4 Door	30"	0.75	90	0.75	90
5 Door	30"	0.94	113	0.94	113
6'	24"	0.39	47	0.39	47
8'	24"	0.43	52	0.43	52
12'	24"	0.68	82	0.68	82



JNRBHSA



ALL MEASUREMENTS ARE TAKEN PER ASHRAE-72 SPECIFICATIONS. HILLPHOENIX REFRIGERATED DISPLAY CASES FOR SALE IN THE UNITED STATES MEET OR EXCEED DEPARTMENT OF ENERGY 2017 REQUIREMENTS.

Rev. Date	Rev. #	Rev. Title
11-10-25	5	DATA UPDATE
07-16-25	4	DATA UPDATE

# A3: TECHNICAL REFERENCE SHEET

# JNRBHSA

2, 3, 4 & 5 Door / 6', 8', 12' High Narrow Reach-In Self Contained Merchandiser  
Beverage/Bakery/Dairy/Cut Produce/Deli



GUIDELINES AND CONTROL SETTINGS				
Application	Superheat Set Point @ Bulb (°F)	Discharge Air (°F)	Set Point Differential (°F)	Discharge Air Velocity (FPM)
Beverage	6 - 8	35	6	230
Bakery/Dairy/Cut Produce	6 - 8	30	6	230
Deli	6 - 8	29	6	230

CONDENSING UNIT DATA									
Case Length	Volts	Phase	Frequency (Hz)	Horsepower	Running Load Amps (RLA)	Locked Rotor Amps (LRA)	Refrigerant	Refrigerant (g)	
2 Door	120	1	60	1/3	4.3	16.7	R-290	130	
3 Door	120	1	60	1/3	4.3	16.7	R-290	140	
4 Door	120	1	60	1/3	5.3	32.0	R-290	145	
5 Door	120	1	60	1/2	8.4	40.2	R-290	150	
6'	120	1	60	1/3	4.3	16.7	R-290	130	
8'	120	1	60	1/3	5.3	32.0	R-290	134	
12'	120	1	60	1/2	8.4	40.2	R-290	150	

DEFROST CONTROLS			
Case Length	Defrosts Per Day	Fail-Safe (Min)	Termination Temp (°F)
2-5 Door	2	46	40
6', 8', 12'	4	46	36

**NOTES:**

- "----" indicates that this feature is not an option on this case model.
- The 24 Hour Energy Value is based upon AHRI 1200 test conditions with Hillphoenix provided evaporator fans, condensing unit, LED lights, occupancy sensor based (on/off) lighting control, dew point based anti-sweat heat controller, condensate pump, evaporator pan, heated door frame, and heated glass doors/electric defrost on low temp cases.
- Heat dissipated to room listed for maximum design conditions, normal operating loads may be lower.
- Data listed is for Optimax. For other lighting options please contact your sales representative.
- Light wattages above reflect 100% run time. To determine actual daily energy usage at 75°F/55%RH conditions, reduce the light wattages above by 42%.
- The recommended evaporator temperature and defrost settings may need to be adjusted based on system setup, store conditions, etc. The minimum recommended evaporator temperature is 4°F below the listed evaporator temperature.
- Discharge air temperature values represent readings taken within the upper air channel immediately behind/upstream of the honeycomb.
- Listed discharge air velocity represents the average velocity immediately after defrost completion using a Testo 410i vane anemometer with anemometer air scoop (HP part number P109185M) positioned adjacent to the interior edge of the discharge honeycomb.



COMPONENT  
ALL MEASUREMENTS ARE TAKEN PER ASHRAE-72 SPECIFICATIONS. HILLPHOENIX REFRIGERATED DISPLAY CASES FOR SALE IN THE UNITED STATES MEET OR EXCEED DEPARTMENT OF ENERGY 2017 REQUIREMENTS.

JNRBHSA

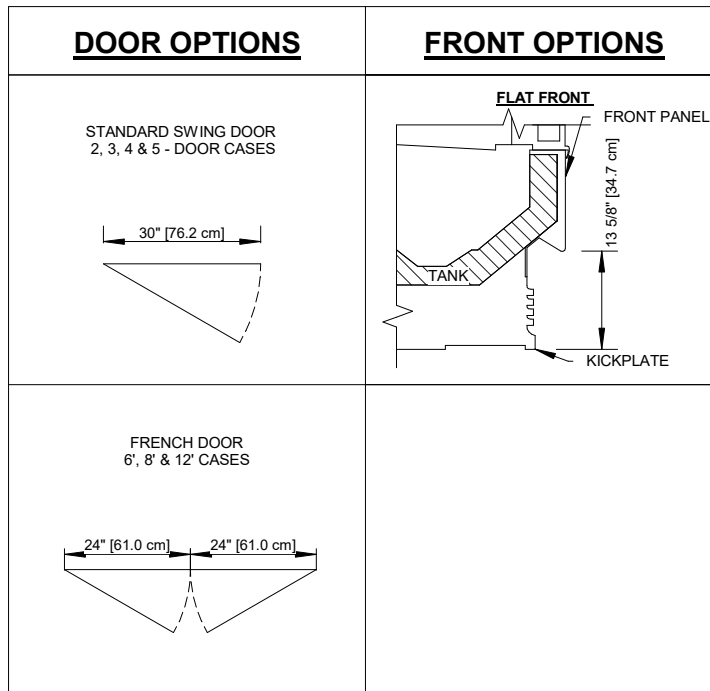
Rev. Date	Rev. #	Rev. Title
11-10-25	5	DATA UPDATE
07-16-25	4	DATA UPDATE



A4: TECHNICAL REFERENCE SHEET

**JNRBHSA**

2, 3, 4 & 5 Door / 6', 8', 12' High Narrow Reach-In Self Contained Merchandiser  
Beverage/Bakery/Dairy/Cut Produce/Deli



COMPONENT

ALL MEASUREMENTS ARE TAKEN PER ASHRAE-72 SPECIFICATIONS. HILLPHOENIX REFRIGERATED DISPLAY CASES FOR SALE IN THE UNITED STATES MEET OR EXCEED DEPARTMENT OF ENERGY 2017 REQUIREMENTS.

JNRBHSA

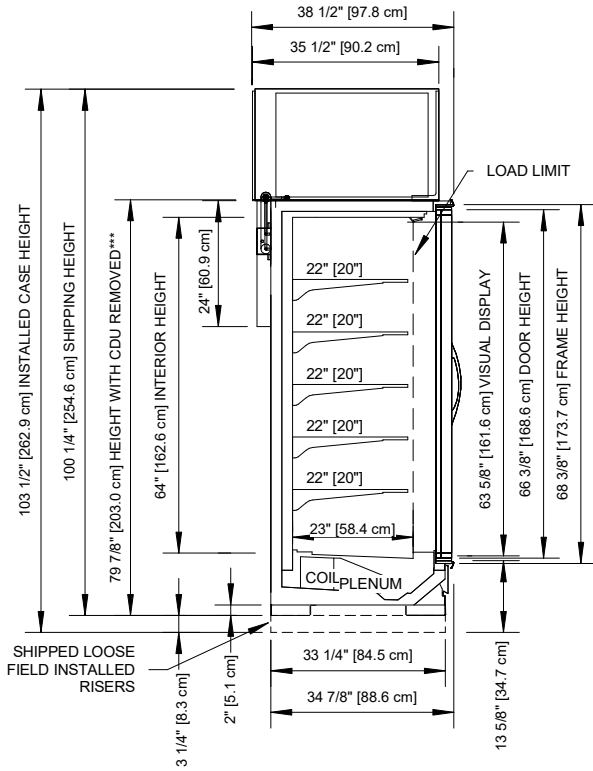
Rev. Date	Rev. #	Rev. Title
11-10-25	5	DATA UPDATE
07-16-25	4	DATA UPDATE



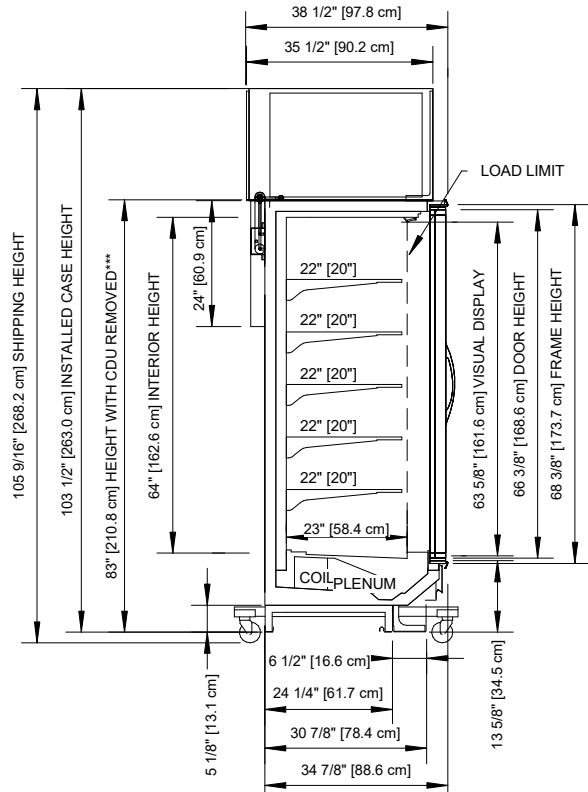
# A5: TECHNICAL REFERENCE SHEET

# JNRBHSA

2, 3, 4 & 5 Door / 6', 8', 12' High Narrow Reach-In Self Contained Merchandiser  
Beverage/Bakery/Dairy/Cut Produce/Deli



**SPECIALIZED**



**STANDARD**



COMPONENT

ALL MEASUREMENTS ARE TAKEN PER ASHRAE-72 SPECIFICATIONS. HILLPHOENIX REFRIGERATED DISPLAY CASES FOR SALE IN THE UNITED STATES MEET OR EXCEED DEPARTMENT OF ENERGY 2017 REQUIREMENTS.

JNRBHSA

Rev. Date	Rev. #	Rev. Title
11-10-25	5	DATA UPDATE
07-16-25	4	DATA UPDATE



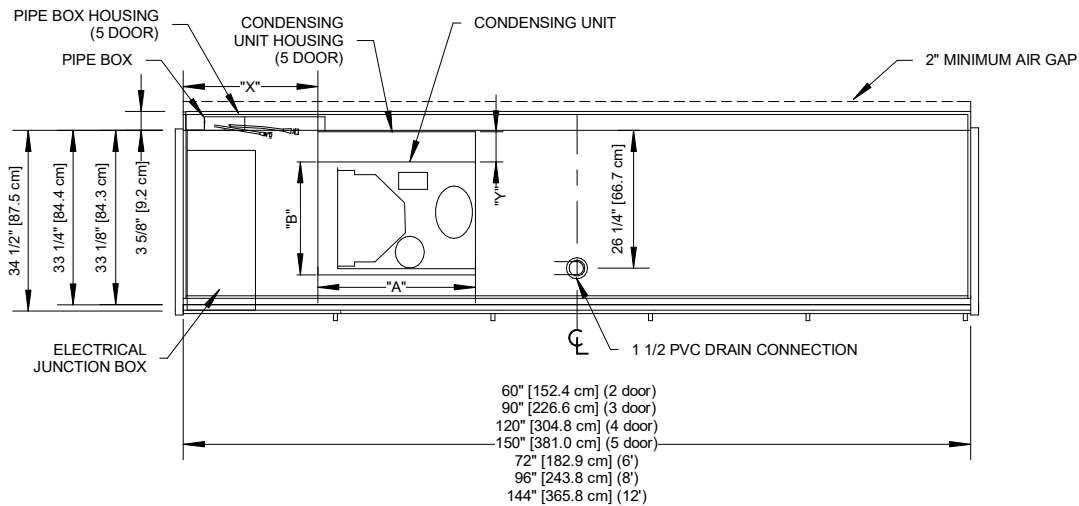
# A6: TECHNICAL REFERENCE SHEET

# JNRBHSA

2, 3, 4 & 5 Door / 6', 8', 12' High Narrow Reach-In Self Contained Merchandiser  
Beverage/Bakery/Dairy/Cut Produce/Deli



CONDENSING UNIT SIZE AND POSITION R-290							
CASE LENGTH	2DR	3DR	4DR	5DR	6'	8'	12'
"X"	25.63"	25.63"	25.63"	25.63"	25.63"	25.63"	25.63"
"Y"	7.94"	7.94"	7.94"	7.94"	7.94"	7.94"	7.94"
"A"	21"	21"	25.9"	25.9"	21"	25.9"	25.9"
"B"	17.2"	17.2"	17.2"	17.2"	17.2"	17.2"	17.2"



**NOTES:**

- \* : STUB-UP AREA.
- \*\* : RECOMMENDED STUB-UP CENTERLINE FOR ELECTRICAL AND HUB DRAINS.
- Specialized Base Frame (available on door length models ONLY):
- Case fits through 80" doorway in the as shipped configuration with 2" fork lift brackets.
- 2" lifting brackets (installed) & 3.25" ship loose risers combine for 5" baseframe once installed.
- Drain traps ship loose.
- Ends add approximately 1" to case height, 1/2" to the back & 1" to the front.



COMPONENT  
ALL MEASUREMENTS ARE TAKEN PER ASHRAE-72 SPECIFICATIONS. HILLPHOENIX REFRIGERATED DISPLAY CASES FOR SALE IN THE UNITED STATES MEET OR EXCEED DEPARTMENT OF ENERGY 2017 REQUIREMENTS.

JNRBHSA

Rev. Date	Rev. #	Rev. Title
11-10-25	5	DATA UPDATE
07-16-25	4	DATA UPDATE



# A7: TECHNICAL REFERENCE SHEET

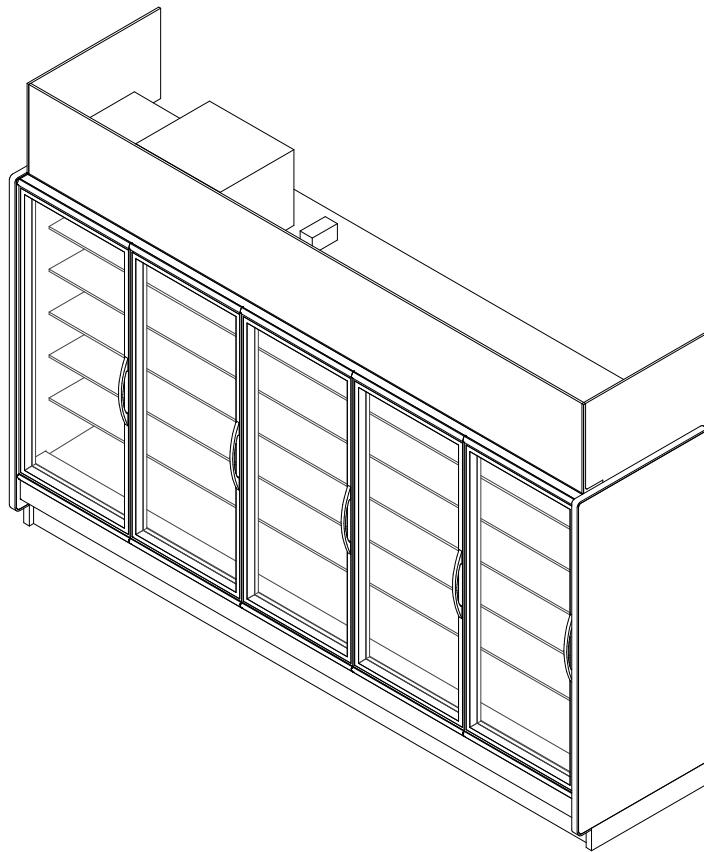
## JNRZHSA

2, 3, 4 & 5 Door High Narrow Reach-In Self Contained Merchandiser  
Frozen Food/Ice Cream



**GENERAL NOTES:**

- "---" indicates that the feature is not an option with this case model and/or the data is not available at this time.
- Light controls - occupancy sensors are required for heated doors only. Low E doors do not require the sensors.
- Option 1: OEM Provided: OEM anti-condensate and lighting controls (on/off) are standard unless otherwise specified.
- Option 2: End User Provided: Light controls should be based on occupancy sensors. Store level A/S control should be set to 30% minimum off time at 75°F/55%RH.
- WARNING: R-290 flammable refrigerant in use. Read the installation, operating and maintenance instructions thoroughly before installing or servicing this equipment.



SHIPPING WEIGHT	
Case	Weight
JNRZHSA	---



COMPONENT  
ALL MEASUREMENTS ARE TAKEN PER ASHRAE-72 SPECIFICATIONS. HILLPHOENIX REFRIGERATED DISPLAY CASES FOR SALE IN THE UNITED STATES MEET OR EXCEED DEPARTMENT OF ENERGY 2017 REQUIREMENTS.

**JNRZHSA**

Rev. Date	Rev. #	Rev. Title
11-10-25	7	DATA UPDATE
07-16-25	6	DATA UPDATE



# A8: TECHNICAL REFERENCE SHEET

# JNRZHS A

2, 3, 4 & 5 Door High Narrow Reach-In Self Contained Merchandiser  
Frozen Food/Ice Cream



### SYSTEM REQUIREMENT

Case Length	Volts	Wiring Type	Phase	Frequency (Hz)	Optional Factory Installed Plug	MCA	MOP	24hr Energy Usage (kWh)	Heat Dissipated to Room (BTUH)
2 Door	120/208	3 Wire + Gnd	1	60	NEMA 14-20/L14-20	8.8	15.0	19.7	3139.0
3 Door	120/208	3 Wire + Gnd	1	60	NEMA 14-20/L14-20	12.8	15.0	30.4	3719.1
4 Door	120/208	3 Wire + Gnd	1	60	NEMA L14-30	31.1	45.0	39.5	7062.8
5 Door	120/208	3 Wire + Gnd	1	60	NEMA L14-30	32.0	45.0	47.0	7915.8

### ELECTRICAL DATA

Case Length	Fans Per Case	Evaporator Fans	
		120 Volts	
		Amps	Watts
2 Door	1	0.42	34
3 Door	2	0.84	68
4 Door	3	1.26	102
5 Door	3	1.26	102

### LIGHTING DATA

Case Length	Door Size	OP7 Single Swing	
		120 Volts	
		Amps	Watts
2 Door	30"	0.28	33.0
3 Door	30"	0.41	49.2
4 Door	30"	0.55	65.4
5 Door	30"	0.68	81.6

### ANTI CONDENSATE DATA

Case Length	Door Size	Individual Circuits									
		190 Doors				ELMD Doors				Door Frame	
		Heated Doors		Low E Doors		Heated Doors		Low E Doors		101-LE	
		120 Volts		120 Volts		120 Volts		120 Volts		120 Volts	
		Amps	Watts	Amps	Watts	Amps	Watts	Amps	Watts	Amps	Watts
2 Door	30"	0.56	67	0.34	40	0.64	76	0.38	45	1.26	151
3 Door	30"	0.84	101	0.51	61	0.95	114	0.57	68	1.76	211
4 Door	30"	1.12	135	0.67	81	1.27	152	0.76	91	2.29	275
5 Door	30"	1.40	169	0.84	101	1.59	191	0.95	114	2.78	334

### GUIDELINES AND CONTROL SETTINGS

Case Length	Application	Superheat Set Point @ Bulb (°F)	Discharge Air (°F)	Set Point Differential (°F)	Discharge Air Velocity (FPM)
2 - 5 Door	Frozen Food	3 - 8	- 2	4	250
2 - 5 Door	Frozen Food	3 - 8	- 2	4	250
2 - 5 Door	Ice Cream	3 - 8	- 9	4	250
2 - 5 Door	Ice Cream	3 - 8	- 9	4	250



COMPONENT  
ALL MEASUREMENTS ARE TAKEN PER ASHRAE-72 SPECIFICATIONS. HILLPHOENIX REFRIGERATED DISPLAY CASES FOR SALE IN THE UNITED STATES MEET OR EXCEED DEPARTMENT OF ENERGY 2017 REQUIREMENTS.

## JNRZHS A

Rev. Date	Rev. #	Rev. Title
11-10-25	7	DATA UPDATE
07-16-25	6	DATA UPDATE



# A9: TECHNICAL REFERENCE SHEET

# JNRZHS A

2, 3, 4 & 5 Door High Narrow Reach-In Self Contained Merchandiser  
Frozen Food



CONDENSING UNIT DATA								
Case Length	Volts	Phase	Frequency (Hz)	Horsepower	Running Load Amps (RLA)	Locked Rotor Amps (LRA)	Refrigerant	Refrigerant (g)
2 Door	208	1	60	1	3.9	25.4	R-290	150
3 Door	208	1	60	1 1/2	6.1	48.0	R-290	180
4 Door	208	1	60	2 1/2	18.0	75.0	R-290	260
5 Door	208	1	60	2 1/2	18.0	75.0	R-290	300

DEFROST CONTROLS			
Defrosts Per Day	Hot Gas Defrost		
	Run-Off Time (Min)	Fail-Safe (Min)	Termination Temp (°F)
1	0	30	72

### NOTES:

- "---" indicates that this feature is not an option on this case model.
- The 24 Hour Energy Value is based upon AHRI 1200 test conditions with Hillphoenix provided evaporator fans, condensing unit, LED lights, occupancy sensor based (on/off) lighting control, dew point based anti-sweat heat controller, condensate pump, evaporator pan, heated door frame, and heated glass doors/electric defrost on low temp cases.
- Heat dissipated to room listed for maximum design conditions, normal operating loads may be lower.
- Data listed is for Optimax. For other lighting options please contact your sales representative.
- Light wattages above reflect 100% run time. To determine actual daily energy usage at 75°F/55%RH conditions, reduce the light wattages above by 42% and reduce the A/S values above by the minimum off time.
- Anti-condensate heat values for Low E represent a door with no heat on the glass.
- Low energy doors (no heat on the glass) do not require anti-condensate or lighting controls. Frame A/S heat is cycled off during defrost cycles.
- Heated doors (heat on the glass) require anti-condensate and lighting controls. Frame A/S heat is cycled off during defrost cycles.
- The recommended evaporator temperature and defrost settings may need to be adjusted based on system setup, store conditions, etc. The minimum recommended evaporator temperature is 4°F below the listed evaporator temperature.
- Discharge air temperature values represent readings taken within the upper air channel immediately behind/upstream of the honeycomb.
- Listed discharge air velocity represents the average velocity immediately after defrost completion using a Testo 410i vane anemometer with anemometer air scoop (HP part number P109185M) positioned adjacent to the interior edge of the discharge honeycomb.



COMPONENT  
ALL MEASUREMENTS ARE TAKEN PER ASHRAE-72 SPECIFICATIONS. HILLPHOENIX REFRIGERATED DISPLAY CASES FOR SALE IN THE UNITED STATES MEET OR EXCEED DEPARTMENT OF ENERGY 2017 REQUIREMENTS.

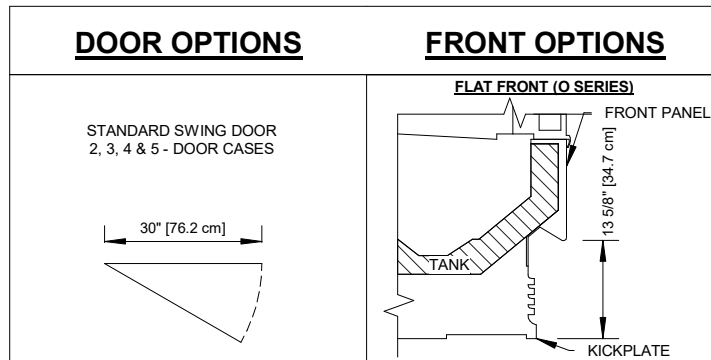
JNRZHS A

Rev. Date	Rev. #	Rev. Title
11-10-25	7	DATA UPDATE
07-16-25	6	DATA UPDATE



# JNRZHS A

2, 3, 4 & 5 Door High Narrow Reach-In Self Contained Merchandiser  
Frozen Food/Ice Cream



COMPONENT  
ALL MEASUREMENTS ARE TAKEN PER ASHRAE-72 SPECIFICATIONS. HILLPHOENIX REFRIGERATED DISPLAY CASES FOR SALE IN THE UNITED STATES MEET OR EXCEED DEPARTMENT OF ENERGY 2017 REQUIREMENTS.

## JNRZHS A

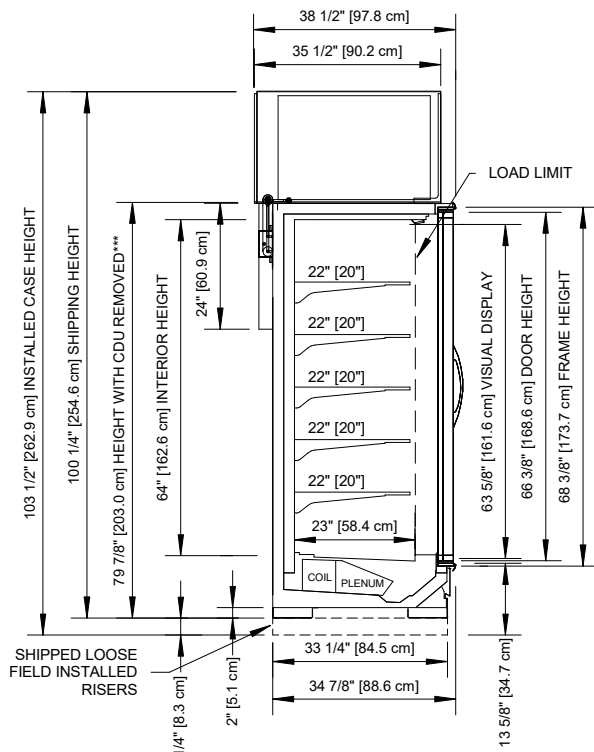
Rev. Date	Rev. #	Rev. Title
11-10-25	7	DATA UPDATE
07-16-25	6	DATA UPDATE



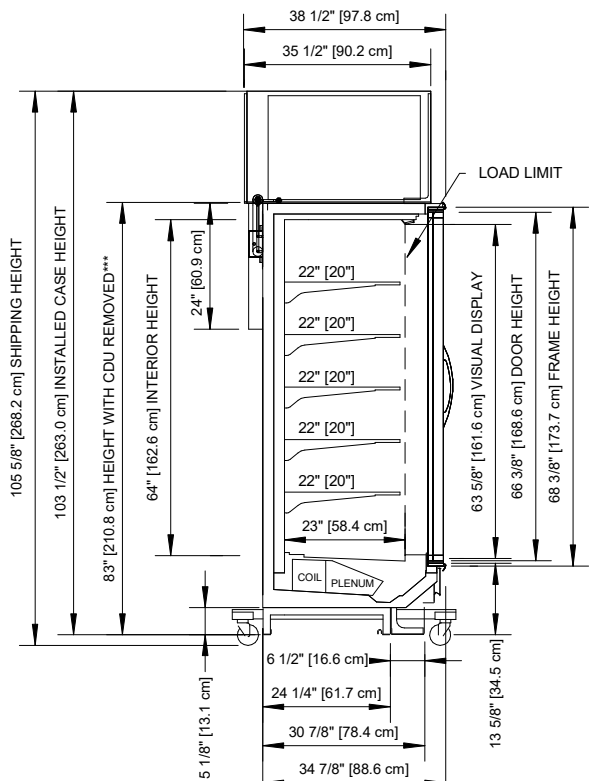
# A11: TECHNICAL REFERENCE SHEET

# JNRZHS A

2, 3, 4 & 5 Door High Narrow Reach-In Self Contained Merchandiser  
Frozen Food/Ice Cream



**SPECIALIZED**



**STANDARD**



COMPONENT

ALL MEASUREMENTS ARE TAKEN PER ASHRAE-72 SPECIFICATIONS. HILLPHOENIX REFRIGERATED DISPLAY CASES FOR SALE IN THE UNITED STATES MEET OR EXCEED DEPARTMENT OF ENERGY 2017 REQUIREMENTS.

JNRZHS A

Rev. Date	Rev. #	Rev. Title
11-10-25	7	DATA UPDATE
07-16-25	6	DATA UPDATE



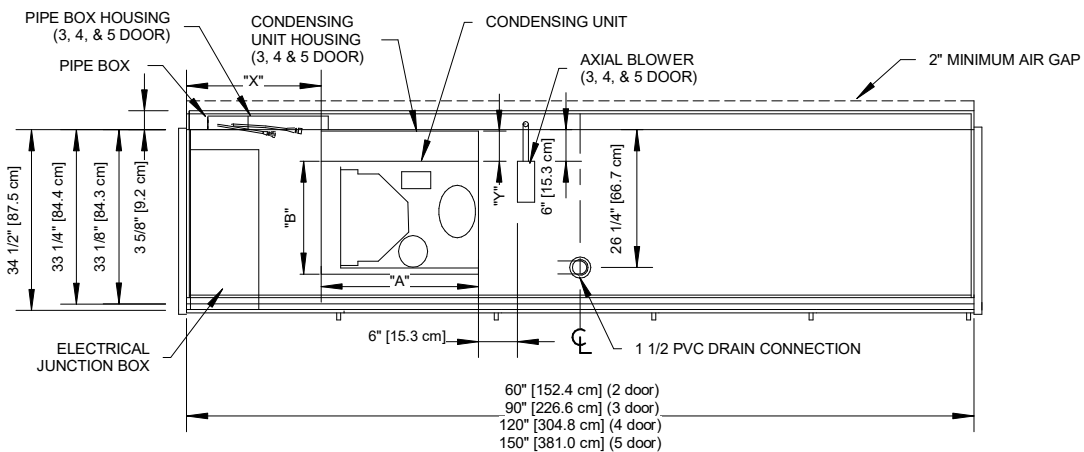
# A12: TECHNICAL REFERENCE SHEET

# JNRZHS A

2, 3, 4 & 5 Door High Narrow Reach-In Self Contained Merchandiser  
Frozen Food/Ice Cream



CONDENSING UNIT SIZE AND POSITION R-290				
CASE LENGTH	2DR	3DR	4DR	5DR
"X"	25.63"	25.63"	25.63"	25.63"
"Y"	7.94"	7.94"	7.94"	7.94"
"A"	25.9"	25.8"	22.75"	22.75"
"B"	17.2"	17.3"	19.89"	19.89"



**NOTES:**

- \* : STUB-UP AREA
- \*\* : RECOMMENDED STUB-UP CENTERLINE FOR ELECTRICAL AND HUB DRAINS
- \*\*\* Specialized Base Frame:
  - Case fits through 80" doorway after CDU is removed in the field.
  - 2" lifting brackets (installed) & 3.25" ship loose risers combine for 5" baseframe once installed.
  - Drain traps ship loose.
  - Ends add approximately 1/2" to the back & 1" to the front (end panel height included in case height).



ALL MEASUREMENTS ARE TAKEN PER ASHRAE-72 SPECIFICATIONS. HILLPHOENIX REFRIGERATED DISPLAY CASES FOR SALE IN THE UNITED STATES MEET OR EXCEED DEPARTMENT OF ENERGY 2017 REQUIREMENTS.

JNRZHS A

Rev. Date	Rev. #	Rev. Title
11-10-25	7	DATA UPDATE
07-16-25	6	DATA UPDATE

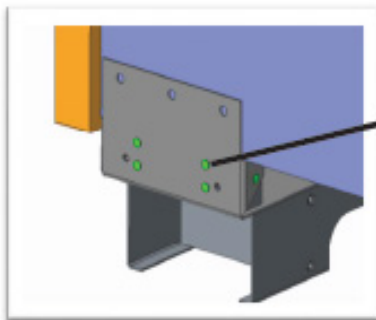


## B1: SEISMIC BRACKETS

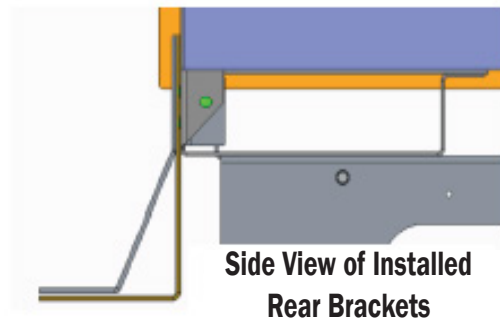
The case constraint brackets are installed on the rear and front base of the case. Brackets are designed for use with the split base frame configuration.

### Rear Brackets Installation:

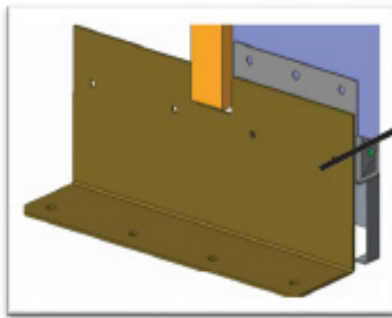
- Two 12G brackets are placed on the rear of the case and captured together by same HILTI thread for improved section modulus of anchor
- Screws pass through both parts and into the factory installed case rear-feet
- Wide part included anchor along case-to-case interface
- Single-width parts for anchor at ends of a single case or ends of line-up



Rear Feet of the Case

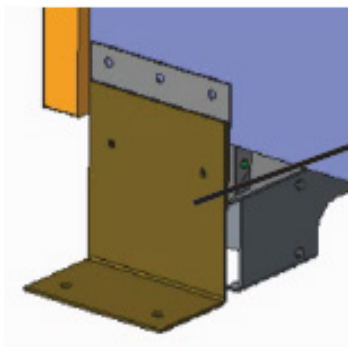
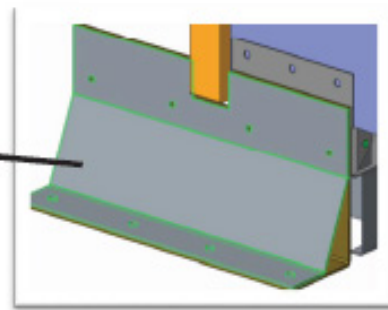


Side View of Installed Rear Brackets



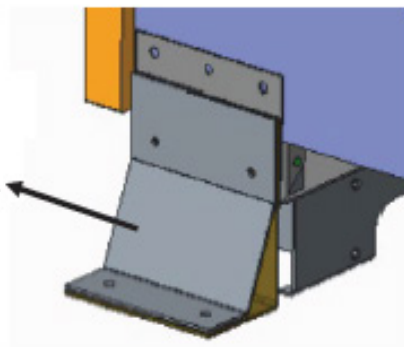
P/No: F885142AGL

P/No: F885144GGL



P/No: F884947FGL

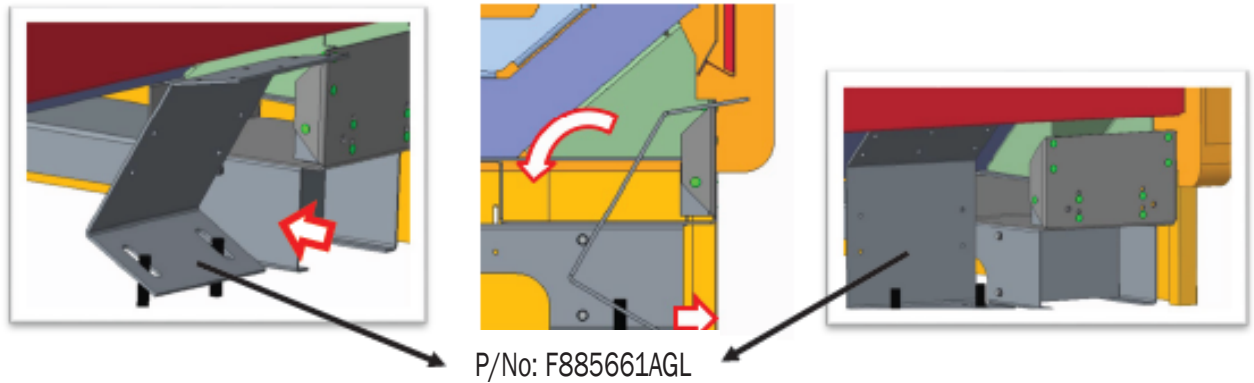
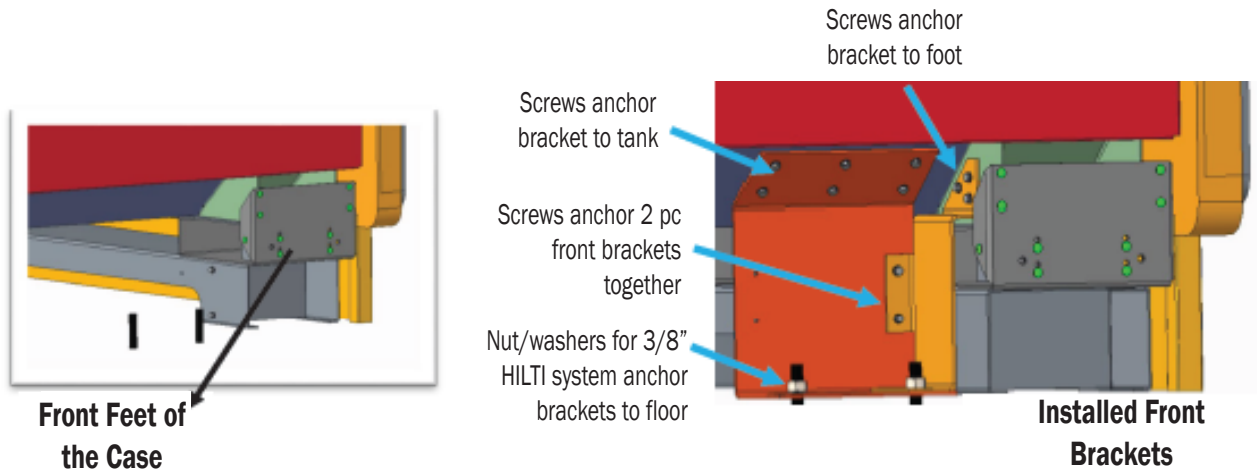
P/No: F885143KGL



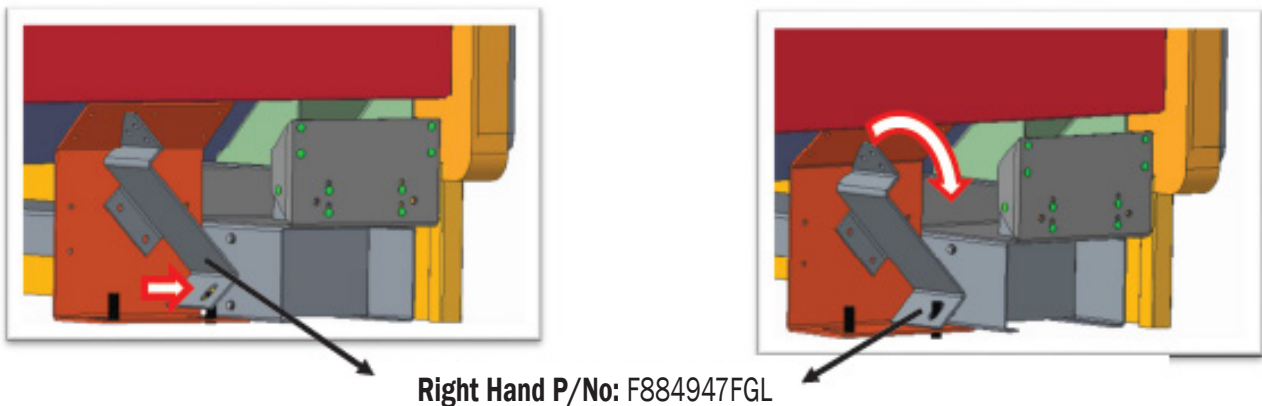
## B2: SEISMIC BRACKETS

### Front Brackets Installation:

- Two piece bracket system is used on the front of the case
- The front field-install brackets remain hidden from shoppers (behind aesthetic kick-plate panels)
- First piece is slotted front to rear so it can rotate onto the 1" tall HILTI threads from front of case



- Second piece rotates from the side
- Left and right hand version of part - for attachment to front base foot
- This part is slotted side-to-side so it can rotate onto the 1" tall HILTI threads from side



Left Hand P/No: (Not Shown in Picture) F885143KGL

# C1: ELECTRICAL WIRING

CAD SYMBOLS		CAD SYMBOLS	
TAG	SYMBOL DESCRIPTION	TAG	SYMBOL DESCRIPTION
CB	1 POLE CIRCUIT BREAKER	H1# / C3#	PLUG CONNECTOR
CB	2 POLE CIRCUIT BREAKER	A1# / H3#	RECEPTACLE CONNECTOR
TB	2 - CONDUCTOR THROUGH TERMINAL BLOCK	RECP	PUMP RECEPTACLE
TB	4 - CONDUCTOR THROUGH TERMINAL BLOCK	FS	FLOAT SWITCH
R / CONT	RELAY / CONTACTOR COIL	PS	HIGH PRESSURE SWITCH
R / CONT	RELAY / CONTACTOR NO OR NC CONTACT	PS	LOW PRESSURE SWITCH
R	FORM C RELAY CONTACT	SW	THERMIDISC T-STAT
SSR	SOLID STATE RELAY	JUMPER	TERMINAL BLOCK SHORT LINK / JUMPER
GND	GROUND CONNECTION	CT	CURRENT TRANSFORMER
DA/DT	TEMPERATURE PROBE	PT	PRESSURE TRANSDUCER
HTR	HEATER	EF	E/VAP FAN
DRIVER / PWS	LED DRIVER / POWER SUPPLY	LS	LIQUID SOLENOID
LIGHT	LED LIGHT	EEV	ELECTRONIC EXPANSION VALVE
AEC	ANTHONY ENERGY CONTROLLER	###	WIRE NUMBER
LSW	LED SWITCH	FU	FUSE
TR	TRANSFORMER	CDU	CONDENSING UNIT
		BL	BLOWER

TAG	SYMBOL DESCRIPTION	SYMBOL
H1# / C3#	PLUG CONNECTOR	
A1# / H3#	RECEPTACLE CONNECTOR	
RECP	PUMP RECEPTACLE	
FS	FLOAT SWITCH	
PS	HIGH PRESSURE SWITCH	
PS	LOW PRESSURE SWITCH	
SW	THERMIDISC T-STAT	
JUMPER	TERMINAL BLOCK SHORT LINK / JUMPER	
CT	CURRENT TRANSFORMER	
PT	PRESSURE TRANSDUCER	
EF	E/VAP FAN	
LS	LIQUID SOLENOID	
EEV	ELECTRONIC EXPANSION VALVE	
###	WIRE NUMBER	
FU	FUSE	
CDU	CONDENSING UNIT	
BL	BLOWER	

REF. W/L T. HG. DOORS.  
 (2) 1/4" DOCS @ 20" VAC  
 MPX ZERO CONTROLLER WITH  
 CONNECTORS, R280.

DATE: 05-24-2024  
 DRAWN BY: SRAI

CHECKED BY: MVC  
 FILE NAME: R010483.LT.PG2

W/ GRANTION SHOWN IS PROPER (AWAY AND COR) AND LOCAL DUPLICATIONS AND  
 USE IS PROHIBITED WITHOUT PERMISSION FROM THE DESIGNER.

PAGE NO: 2 OF 5

REV	DATE	REV. BY	ECN	DESCRIPTION
6	11/14/2024	SHS	123465	MOTION SENSOR WIRING AND TB LAYOUT UPDATED
5	11/05/2024	SRAI	122700	MOTION SENSOR AND VALVE NOMENCLATURE UPDATED
4	10/04/2024	SRAI	123209	BLOWER AND VALVES WIRING UPDATED
3	08/19/2024	SRAI	122929	WIRE GAUGE UPDATED IN THE TB LAYOUT
2	07/19/2024	SRAI	122874	RELAY FOOT PRINT ROTATED & WIRE IS MOVED
1	07-10-2024	SRAI	122870	SAFETY CONTACTOR CKT REPLACED WITH BLOWER CKT
0	05-24-2024	SRAI	122866	FOR INITIAL REVIEW AND RELEASE

\* USE COPIES OF CONDUCTORS ONLY.  
 ALL WIRING MUST BE DONE BEFORE POWER IS APPLIED.  
 ALL WIRING MUST BE DONE IN ACCORDANCE WITH LOCAL CODES.

**Hilti**  
 Energy Care  
 10000 W. 16th Ave.  
 Golden, CO 80401  
 303.440.4300  
 www.hilti.com

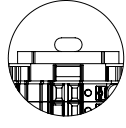
# C2: ELECTRICAL WIRING (JNRBHSA)

NAME: 10088368 OBJECT: R901156 DATE: 02-07-2025 17:56:36

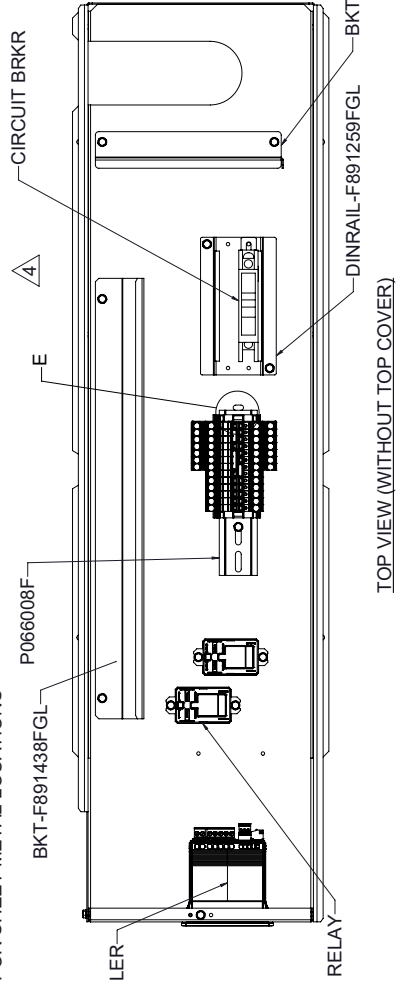
**NOTES-**

USE 19X P058780H FOR COMPONENTS FOR SHEET METAL LOCATIONS

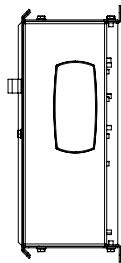
**NOTE:**  
 • FOR ALIGNMENT OF DIN RAIL (P066008F), MOUNT DIN RAIL LINING UP THE END OF THE DIN RAIL TO THE SLOT PROVIDED AS SHOWN IN DETAIL E 



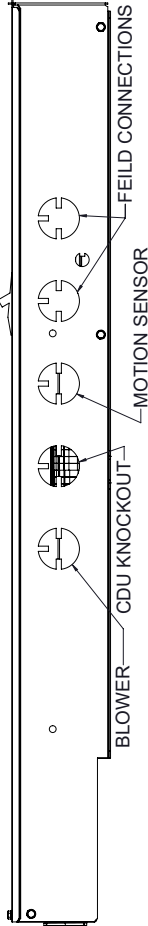
**DETAIL E**



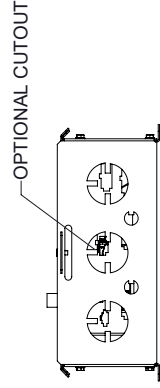
TOP VIEW (WITHOUT TOP COVER)



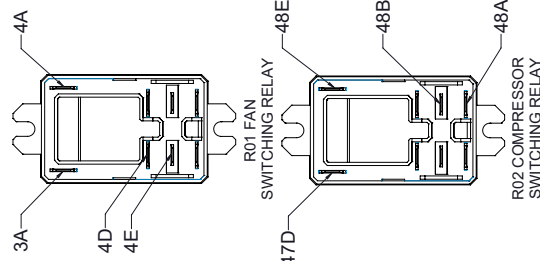
LEFT VIEW



FRONT VIEW



RIGHT VIEW



F905501DGL TOP COVER

F908482CGL SIDE

ISOMETRIC VIEW ONLY FOR REFERENCE

F904508EGL TRAY BOTTOM

REV	DATE	ECN NO.	DESCRIPTION
JS	07-02-2025	123733	7 CHANGED SIDE PANEL AND UPDATED TERMINAL BLOCK LAYOUT
JS	01/17/2025	123676	6 ADDED NOTES FOR DIN RAIL ALIGNMENT
JS	11/14/2024	123465	5 UPDATED TERMINAL BLOCK LAYOUT
EE	10/22/2024	122700	4 LAYOUT UPDATED FOR R290
EE	7/6/2024	122570	3 LAYOUT UPDATED FOR R290
EE	5/19/2024	122366	2 LAYOUT UPDATED FOR R290
EE	12/4/2023	120838	1 RELEASED TO PRODUCTION
REV	DATE	ECN NO.	DESCRIPTION

**ASSEMBLY TYPE: Sub-Assembly**  
 TOLERANCES: (UNLESS SPECIFIED)  
 UNITS: INCH (FRACTIONS)  
 DECIMALS: ±.002  
 ANGLES: ±.000  
 HOLE DIA: ±.000  
 HOLE DIA: ±.000  
 DRAWING NOT TO SCALE

**Hilphenix**  
 10000 Hillphenix Drive  
 Springfield, VA 22154  
 (703) 461-1000

**R901156**

REF: AS\_ELE-JBOX\_JNRBHSA-R290

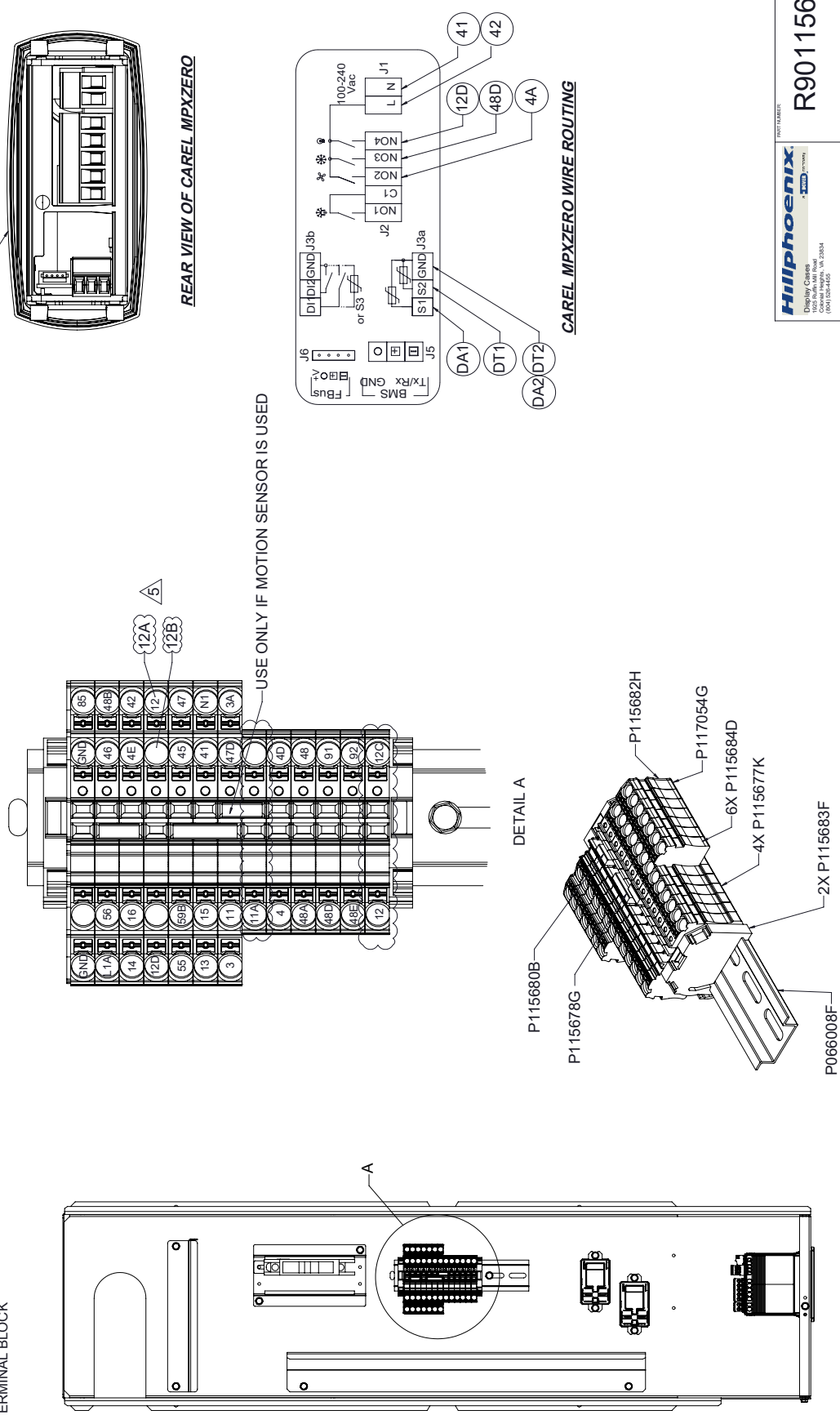
DATE: 04-12-2023  
 DRAWN BY: EE  
 SHEET: 1 OF 2

INFORMATION SHOWN IS PROPRIETARY AND CONFIDENTIAL. DUPLICATION AND USE IS PROHIBITED WITHOUT PERMISSION FROM HILPHENIX

\*\*\*DRAWING GENERATED IN SOLIDWORKS\*\*\*

# C3: ELECTRICAL WIRING (JNRBHSA)

NOTE:  
 USE R904884 AS REF FOR MT SCHEMATICS  
 UNLESS OTHERWISE SPECIFIED, WIRES COMES FROM PIG TAIL HARNESS  
 TB-TERMINAL BLOCK



DRAWING GENERATED IN SOLIDWORKS

Hilphoenix  
 17020 Highway 101 West  
 Everett, WA 98203  
 (206) 835-2400

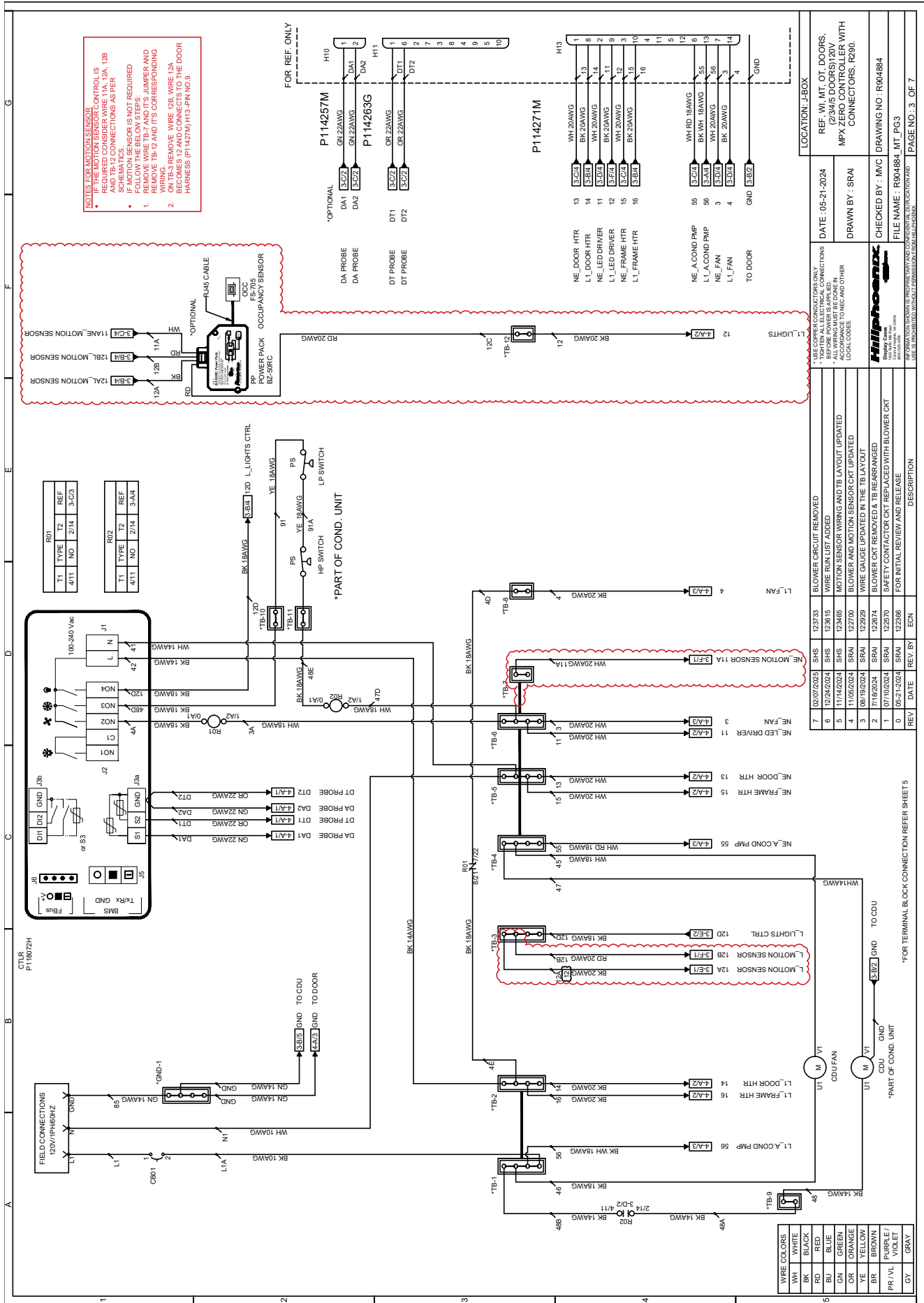
PART NUMBER: **R901156**

DRAWN BY: EE DATE: 04-12-2023 SHEET: 2 OF 2

REF: AS, ELE-JBOX, JNRBHSA-R290

INFORMATION SHOWN IS PROPRIETARY AND CONFIDENTIAL. DUPLICATION AND USE IS PROHIBITED WITHOUT PERMISSION FROM HILPHOENIX

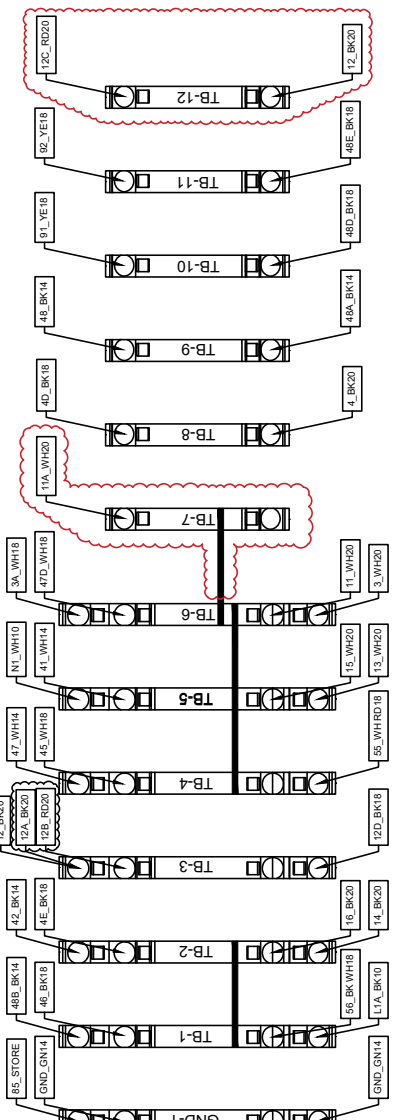
# C4: ELECTRICAL WIRING (JNRBHSA)



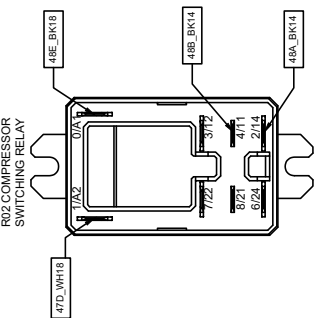


# C6: ELECTRICAL WIRING (JNRBHSA)

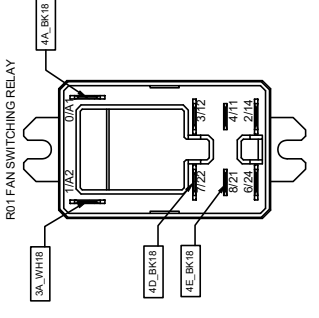
**NOTES FOR MOTION SENSOR:**  
 IF THE MOTION SENSOR CONTROL IS REQUIRED CONSIDER WIRE 11A, 12A, 12B AND TB-12 CONNECTIONS AS PER THE FOLLOWING STEPS:  
 IF MOTION SENSOR IS NOT REQUIRED FOLLOW THE BELOW STEPS:  
 REMOVE WIRE TB-7 AND ITS JUMPER AND WIRE TB-12 AND IT'S CORRESPONDING WIRING.  
 ON TB-3 REMOVE WIRE 12B. WIRE 12A BECOMES 12 AND CONNECTS TO THE DOOR HARNESS (P1162) PIN NO. 3.



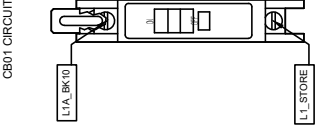
USED FOR	GROUND	PHASE - L1	NEUTRAL	FAN	CONSENSING UNIT	LIGHTS
WIRE FROM / TO	STORE	CDU FAN	CDU FAN	R01(7/22)	CDU PRESSURE SWITCH	MOTIONS NSR
WIRE #_COLOR-AWG	86_STORE	48B_BK14	47_WH14	3A_WH18	3A_WH18	12C_RD20
WIRE #_COLOR-AWG	GND_GN14	46_BK18	45_WH18	11A_WH20	4D_BK18	92_YE18
TERMINAL BLOCK TAG	GND-1	TB-1	TB-4	TB-7	TB-8	TB-10
WIRE #_COLOR-AWG	GND-1	56_BK_WH18	16_BK20	4_BK20	48A_BK14	48E_BK18
WIRE #_COLOR-AWG	GND_GN14	L1A_BK10	55_WH_RD18	11_WH20	48A_BK14	48D_BK18
WIRE FROM / TO	DOOR	L_ANTILOC DPUMP	NE_ANTILOC DPUMP	HARNESS(H13)	CTDR(M03)	R02(0A1)
		G5-01	HARNESS(H13)	R02(2H4)	R02(0A1)	R02(0A1)



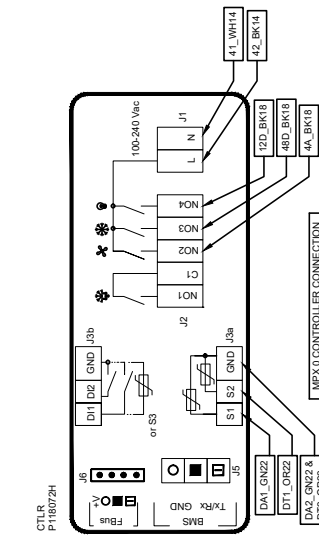
RELAY PIN	WIRE #_COLOR-AWG
0A1	48E_BK18
1A2	47D_WH18
2H4	48A_BK14
4T1	48B_BK18



RELAY PIN	WIRE #_COLOR-AWG
0A1	4A_BK18
1A2	3A_WH18
2H4	4D_BK18
4E1	4E_BK18



BREAKER PIN	WIRE #_COLOR-AWG
1/L1	L1_STORE
2/U2	L1A_BK10



CTDR PIN	WIRE #_COLOR-AWG
N	42_BK14
N	41_BK14
N01	4A_BK18
N02	4A_BK18
N03	48D_BK18
N04	12D_BK18
S1	D01_OR22
S2	D01_OR22
GND	D02_OR22 & D02_OR22

REV	DATE	REV. BY	ECN	DESCRIPTION
7	10/07/2025	SHS	123735	BLOWER CIRCUIT REMOVED
6	12/24/2024	SHS	123815	WIRE RUN LIST ADDED
5	11/14/2024	SHS	123465	MOTION SENSOR WIRING AND TB LAYOUT UPDATED
4	11/05/2024	SRAI	122700	BLOWER AND MOTION SENSOR CKT UPDATED
3	08/19/2024	SRAI	122929	WIRE GAUGE UPDATED IN THE TB LAYOUT
2	7/18/2024	SRAI	122874	BLOWER CKT REMOVED & TB REARRANGED
1	07/10/2024	SRAI	122570	SAFETY CONTACTOR CKT REPLACED WITH BLOWER CKT
0	05-21-2024	SRAI	122366	FOR INITIAL REVIEW AND RELEASE

DATE:	05-21-2024
DRAWN BY:	SRAI
CHECKED BY:	MVC
FILE NAME:	R904884_MT_PG5
LOCATION:	JBOX

USE COPPER CONDUCTORS ONLY  
 USE ONE POWER SUPPLY  
 WIRING SHALL BE ACCORDANCE TO NEC AND OTHER LOCAL CODES.  
**Hilphoenix**  
 Design Center  
 10000 W. 10th Ave.  
 Denver, CO 80202  
 USA  
 INFORMATION SHOWS PROPRIETARY AND CONFIDENTIAL INFORMATION AND IS TO BE KEPT OUTSIDE COMPANY PERIPHERY.



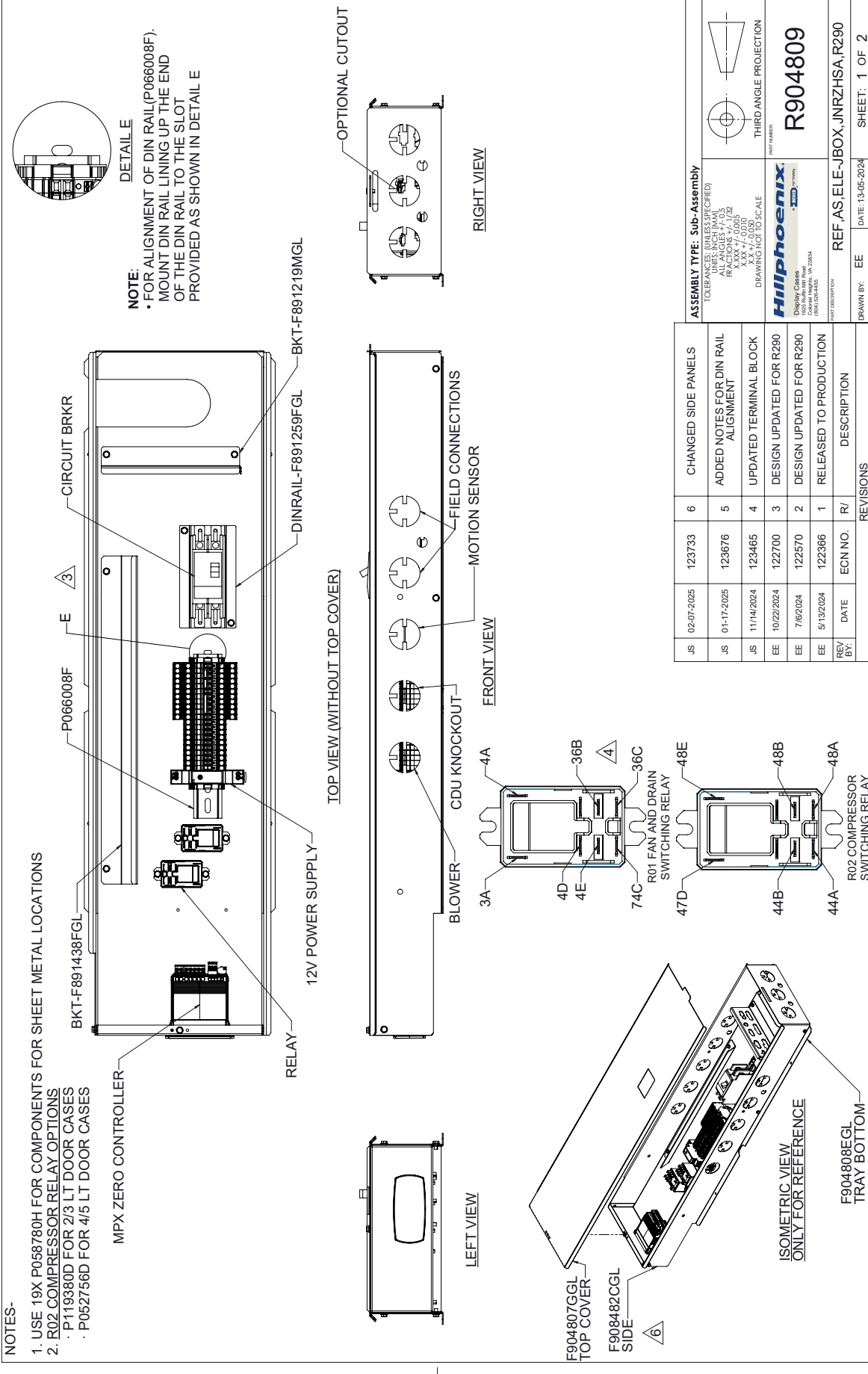


# C9: ELECTRICAL WIRING (JNRZHSA)

NAME: I0088368 OBJECT: R904809 DATE: 02-07-2025 17:55:30

**NOTES-**

1. USE 19X P058780H FOR COMPONENTS FOR SHEET METAL LOCATIONS
2. R02 COMPRESSOR RELAY OPTIONS
  - P119380D FOR 2/3 LT DOOR CASES
  - P052756D FOR 4/5 LT DOOR CASES



REV	BY	DATE	ECN NO.	R/	DESCRIPTION
JS	05-07-2025	123733	6		CHANGED SIDE PANELS
JS	01-17-2025	123676	5		ADDED NOTES FOR DIN RAIL ALIGNMENT
JS	11/14/2024	123465	4		UPDATED TERMINAL BLOCK
EE	10/22/2024	122700	3		DESIGN UPDATED FOR R290
EE	7/6/2024	122570	2		DESIGN UPDATED FOR R290
EE	5/13/2024	122366	1		RELEASED TO PRODUCTION
REV	BY	DATE	ECN NO.	R/	DESCRIPTION

**ASSEMBLY TYPE: Sub-Assembly**

TOLERANCES (UNLESS SPECIFIED)  
 DIMENSIONS IN INCHES  
 FRACTIONS 1/16, 1/32  
 DECIMALS .1, .125  
 ANGLES 1/2, 1/4, 3/8, 1/2, 3/4, 1, 1.5  
 HOLE DIA .0005  
 DRAWING IS NOT TO SCALE

**Hilphoenix**  
 Division of  
 10000 W. Hill Road  
 Dallas, TX 75243  
 (972) 232-8800

REF: AS, ELE-JBOX, JNRZHSA, R290

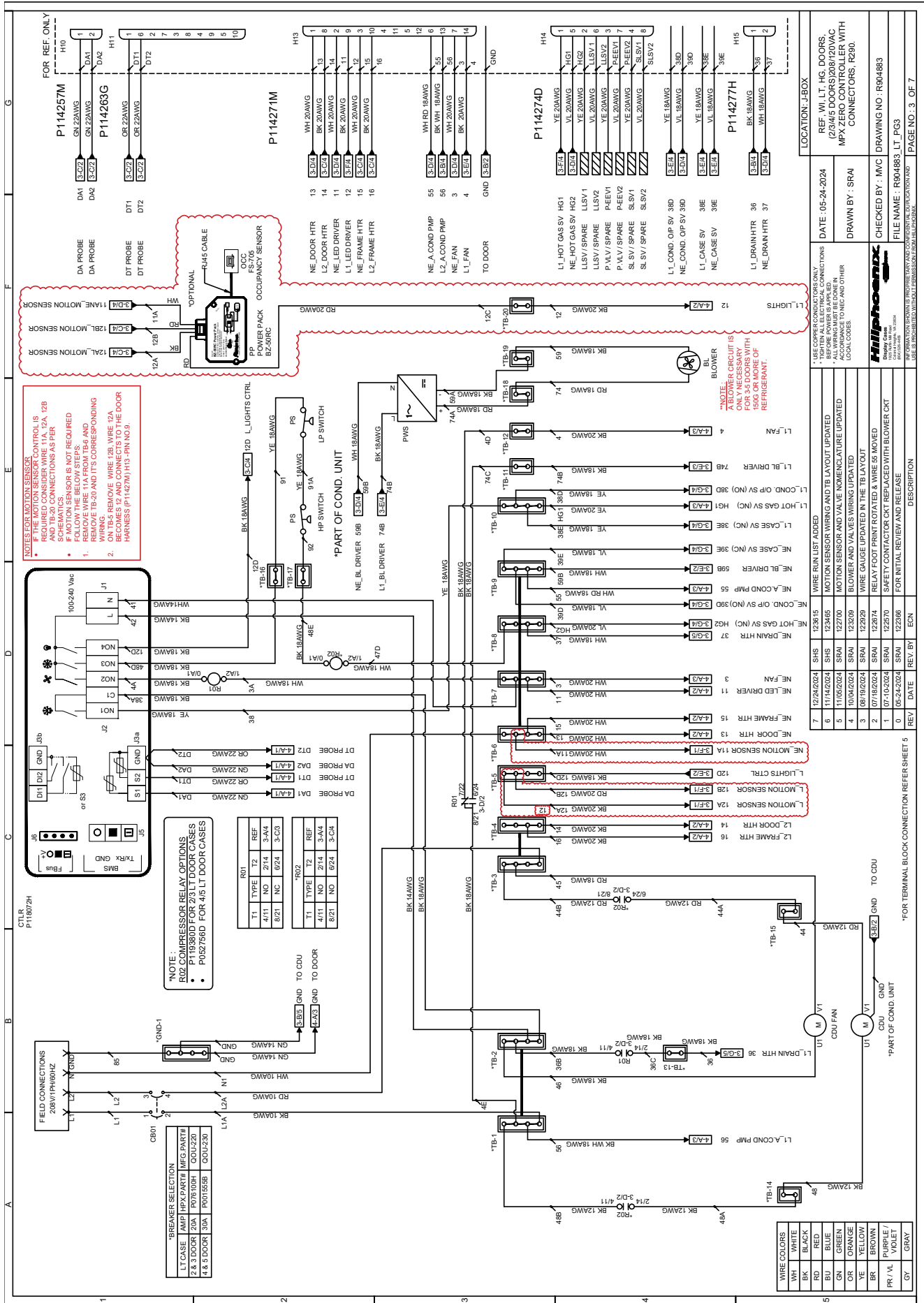
DATE: 13-05-2024

SHEET: 1 OF 2

INFORMATION SHOWN IS PROPRIETARY AND CONFIDENTIAL. DUPLICATION AND USE IS PROHIBITED WITHOUT PERMISSION FROM HILPHOENIX



# C11: ELECTRICAL WIRING (JNRZHS)







# C14: ELECTRICAL WIRING (JNRZHS)

SLNO	WIRE #	LENGTH	COLOR	AWG	WIRE P#	WIRE FROM	STRIP LENGTH	TO	STRIP LENGTH	REMARKS
<b>R290, CONNECTORIZED HARNESS -- R904883</b>										
<b>INCOMER WIRES</b>										
1	L1	18"	BLACK	10AWG	P001631A	STORE	0.35"(9MM)	CB01	0.35"(9MM)	
2	L2									
3	L1A	18"	BLACK	10AWG	P001631A	TB-1				
4	L2A					TB-3				
5	N1		WHITE		P001632K	TB-6				
6	85	142"(HARNESS)	GREEN	14AWG	P002454G	GND-1		STORE	0.35"(9MM)	
<b>CONTROLLER</b>										
7	42	18"	BLACK	14AWG	P001548G	CTLR(L)		TB-2		
8	41	18"	WHITE	14AWG	P001547K	CTLR(N)		TB-7		
9	GND	20"	GREEN	14AWG	P002454G	CDU		GND-1	0.47"(12MM)	
10	GND	20"	GREEN	14AWG	P002454G	DOOR				
11	38A	20"	BLACK		P001278A	CTLR(C1)	0.35"(9MM)	TB-2		
12	38		YELLOW		P001417E	CTLR(NO1)		TB-10		
13	4A			18AWG	P001278A	CTLR(NO2)		R01(O/A1)	0.35"(9MM (RED FLG-P096492E))	
14	48D	10"	BLACK			CTLR(NO3)		TB-16		
15	12D					CTLR(NO4)		TB-5	0.47"(12MM)	
<b>RELAYS</b>										
16	3A	10"	WHITE	18AWG	P001277C	R01(L/A2)		TB-7		
17	47D	10"	WHITE	18AWG	P001277C	R02(L/A2)		TB-8		
18	48E	10"	BLACK	18AWG	P001278A	R02(O/A1)		TB-17		
19	4D					R01(F/22)	0.35"(9MM (RED FLG-P096492E))	TB-12		
20	4E					R01(B/21)		TB-2		
21	74C	14"	BLACK	18AWG	P001278A	R01(G/24)		TB-11		
22	36B					R01(G/11)		TB-2		
23	36C					R01(Z/14)		TB-13	0.47"(12MM)	
24	44B					R02(B/21)	0.35"(9MM (YEL FLG-P042307K))	TB-3		
25	44A		RED		P001630C	R02(G/24)		TB-15		
26	44			12AWG		CDU	0.35"(9MM)	TB-15		
27	48B	18"	BLACK		P001629E	R02(G/11)	0.35"(9MM (YEL FLG-P042307K))	TB-1		
28	48A					R02(L/14)		TB-14		
29	48					CDU		TB-15		
30	45		RED	18AWG	P001415K	CDU FAN	0.35"(9MM)	TB-3		
31	46		BLACK		P001278A	CDU FAN		TB-2		

REV	DATE	BY	ECN	DESCRIPTION
7	12/24/2024	SHS	123615	WIRE RUN LIST ADDED
6	11/14/2024	SHS	123465	MOTION SENSOR WIRING AND TB LAYOUT UPDATED
5	11/05/2024	SRAL	122700	MOTION SENSOR AND VALVE Nomenclature UPDATED
4	10/04/2024	SRAL	123209	BLOWER AND VALVES WIRING UPDATED
3	09/19/2024	SRAL	122929	WIRE GAUGE UPDATED IN THE TB LAYOUT
2	07/16/2024	SRAL	122674	RELAY FOOT PRINT ROTATED & WIRE SIZE MOVED
1	07-10-2024	SRAL	122570	SAFETY CONTACTOR CKT REPLACED WITH BLOWER CKT
0	05-24-2024	SRAL	122386	FOR INITIAL REVIEW AND RELEASE

<small>USE COPPER CONDUCTORS ONLY BEFORE POWER IS APPLIED. WIRING SHALL BE PERFORMED ACCORDANCE TO IEC AND OTHER LOCAL CODES.</small>	<small>DATE: 05-24-2024 DRAWN BY: SRAL CHECKED BY: IMC DRAWING NO: R904883</small>	<small>REF: W/ L.T. HG. DOORS, (2) 3/4" DOORS/28" MPX ZERO CONTROLLER WITH CONNECTORS, R290.</small>
<small>INFORMATION SHOWN IS PROPRIETARY AND CONFIDENTIAL. OUR POLICY AND USE IS PROHIBITED WITHOUT PERMISSION FROM ILLUMINOX.</small>	<small>FILE NAME: R904883.LT.PG6 PAGE NO: 6 OF 7</small>	

# C15: ELECTRICAL WIRING (JNRZHSA)

A		B		C		D		E		F		G	
<b>HARNESSES</b>													
32	DA1	30"(HARNESSES)	GREEN	22AWG	P114271M (HARNESSES)	HARNESSES (H10)	NA	CTLR(S1)	0.354"(HARNESSES)				
33	DA2							CTLR(GND)					
34	DT1	30"(HARNESSES)	ORANGE	22AWG	P114280C (HARNESSES)	HARNESSES (H11)	NA	CTLR(S2)	0.354"(HARNESSES)				
36	13		WHITE					TB-6					
37	15												
38	14		BLACK					TB-4					
39	16												
40	11	18.11"(HARNESSES)	WHITE	20AWG	P114271M (HARNESSES)	HARNESSES (13)	NA	TB-7	0.354"(HARNESSES)				
41	12		BLACK					TB-12					
42	3		WHITE					TB-9					
43	4		BLACK					TB-1					
44	55		WHITE	18AWG				TB-10					
45	56		BLACK					TB-8					
46	HG1	18.11"(HARNESSES)	YELLOW	20AWG	P114274D (HARNESSES)	HARNESSES (H14)	NA	TB-13	0.354"(HARNESSES)				
47	HG2		VIOLET					TB-8					
48	36	18.11"(HARNESSES)	BLACK	18AWG	P114277H (HARNESSES)	HARNESSES (15)	NA	TB-8	0.354"(HARNESSES)				
49	37		WHITE										
50	38D		YELLOW		P001417E	COND OUTPUT SOL VALVE		TB-10					
51	39D	20"	VIOLET	18AWG	P014403M		0.35"(9MM)	TB-9	0.47"(12MM)				
52	38E		YELLOW		P001417E	CASE SOL VALVE		TB-10					
53	39E		VIOLET		P014403M			TB-9					
54	12(OR 12A)	18.11"(HARNESSES)/ 7" M_SNSR-BK	BLACK	20AWG	HARNESSES / (M_SNSR-BK)	HARNESSES (13)/ (M_SNSR-BK)	NA	TB-5	0.354"(HARNESSES)				
55	12B	7"	RED	20AWG	M_SNSR WIRE	M_SNSR-RD	NA	TB-5	0.47"(12MM)				OPTIONAL
56	12C		WHITE			M_SNSR-WH		TB-20					
57	11A		YELLOW	18AWG		LP SWITCH	NA	TB-16	0.357(9MM)				
59	91A		YELLOW	18AWG	P001417E	HP SWITCH	NA	LP SWITCH	0.357(9MM)				
60	92		YELLOW	18AWG		HP SWITCH	NA	TB-17	0.357(9MM)				
61	74B		BLACK		P001278A	PWS(L)	NA	TB-11					
62	74A	15"	RED			PWS(+)		TB-18					
63	74		RED	18AWG	P001415K	BLOWER	0.35"(9MM)	TB-18	0.357(9MM)				
64	59B		WHITE		P001277C	PWS(N)		TB-9					
65	59A		BLACK			PWS(-)		TB-19					
66	59		BLACK		P001278A	BLOWER		TB-19					

REF: W/LT, HG, DOORS, P/M, L DOORS, MPX ZERO CONTROLLER WITH CONNECTORS, R280.

DATE: 05-24-2024  
DRAWN BY: SRAI

CHECKED BY: MCV  
FILE NAME: R904883\_L1.PG7  
DRAWING NO.: R904883

REV	DATE	REV. BY	ECN	DESCRIPTION
7	12/24/2024	SHS	123615	WIRE RUN LIST ADDED
6	11/14/2024	SHS	123485	MOTION SENSOR WIRING AND TBLAYOUT UPDATED
5	11/05/2024	SRAI	122700	MOTION SENSOR AND VALVE NOMENCLATURE UPDATED
4	10/04/2024	SRAI	123209	BLOWER AND VALVES WIRING UPDATED
3	08/19/2024	SRAI	122929	WIRE GAUGE UPDATED IN THE TBLAYOUT
2	07/19/2024	SRAI	122674	RELAY FOOT PRINT ROTATED & WIRE #S MOVED
1	07-10-2024	SRAI	122570	SAFETY CONTACTOR COT REPLACED WITH BLOWER COT
0	05-24-2024	SRAI	122366	FOR INITIAL REVIEW AND RELEASE

\*USE COPPER CONDUCTORS ONLY  
\*ALL WIRING MUST BE DONE IN ACCORDANCE WITH LOCAL CODES.  
\*WIRING MUST BE DONE IN ACCORDANCE WITH LOCAL CODES.

**Hilphoenix**  
Wiring Cable  
Manufactured in USA  
WIRING INFORMATION: PROPER TERRY AND CONDUCTOR SIZE MUST BE USED.  
USE 18 GAUGE WIRE FOR 18 AWG WIRING.

REF: W/LT, HG, DOORS, P/M, L DOORS, MPX ZERO CONTROLLER WITH CONNECTORS, R280.

DATE: 05-24-2024  
DRAWN BY: SRAI

CHECKED BY: MCV  
FILE NAME: R904883\_L1.PG7  
DRAWING NO.: R904883

PAGE NO.: 7 OF 7

# D1: CONTROLLERS AND SETPOINTS

## Parameter table

Code	Description	Def	Min	Max	UOM	User Terminal	JNRBHS	JNRZSHA
<b>Analogue Inputs</b>								
/P1	Type of probe, group 1 (S1, S2, S3) 0 = PT1000 Standard Range -50/150 °C 1 = NTC Standard Range -50/190 °C	1	0	1	-	YES		
/P5	Configuration of analogue output Y1: 0 = 0-10 V, 6 = PWM	6	0	6	-	NO		
/P6	Configuration of analogue output Y2: 0 = 0-10 V, 6 = PWM	6	0	6	-	NO		
/FA	0 = Serial probe S11 1 = Serial probe S12 2 = Serial probe S13 3 = Probe S2 4 = Serial probe S14	1	-4	3	-	YES	1	1
/Fb	Assign defrost temperature probe (S0) - see /FA	2	-4	3	-	YES	2	2
/Fc	Assign defrost temperature probe (S1) - see /FA	3	-4	3	-	YES	0	0
/Fd	Assign defrost temperature probe 2 (S2) - see /FA	0	-4	3	-	YES	0	0
/FE	Assign auxiliary temperature/pressure probe 1 (Saux1) - see /FA	0	-4	3	-	NO		
/FH	Assign auxiliary temperature/pressure probe 2 (Saux2) - see /FA	0	-4	3	-	NO		
/FI	Assign ambient temperature probe (SA) - see /FA	0	-4	3	-	NO		
/FL	Assign ambient humidity probe (SU) - see /FA	0	-4	3	-	NO		
/FM	Assign glass temperature probe (SV) - see /FA	0	-4	3	-	NO		
/FN	Assign dewpoint value (SP) - see /FA	0	-4	3	-	NO		
/GA	Outlet temperature probe (Sm) calibration	0	-20	20	°C/F	NO		
/GB	Inlet temperature probe (Sj) calibration	0	-20	20	°C/F	NO		
/GC	Inlet temperature probe 2 (Sj2) calibration	0	-20	20	°C/F	NO		
/GD	Defrost temperature probe 2 (Sj2) calibration	0	-20	20	°C/F	NO		
/GE	Auxiliary temperature/pressure probe 1 (Saux1) calibration	0	-20	20	°C/F	NO		
/GF	Auxiliary temperature/pressure probe 2 (Saux2) calibration	0	-20	20	°C/F	NO		
/GG	Ambient temperature probe (SA) calibration	0	-20	20	°C/F	NO		
/GH	Ambient humidity probe (SU) calibration	0	-20	20	°C/F	NO		
/GI	Glass temperature probe (SV) calibration	0	-20	20	°C/F	NO		
/GJ	Dewpoint value (SP) calibration	0	-20	20	°C/F	NO		
/GL	Condenser temperature probe calibration	0	-20	20	°C/F	NO		
/GO	Analogue probe measurement stability	9	1	15	-	NO		

Code	Description	Def	Min	Max	UOM	User Terminal	JNRBHS	JNRZSHA
<b>Control</b>								
ON	ON/OFF command 0 = OFF, 1 = ON	0	0	1	-	YES		
/A	Virtual probe composition 0 = Air off probe Sjn 100 = Air on probe S	0	0	100	%	NO		
/Z	Minimum set point	-50	-50	72	°C/F	NO	25	-25
/Z1	Maximum set point	50	71	200	°C/F	NO	80	80
/Z2	Automatic night set point variation 0 = Air off probe Sjn 1 = Inlet probe Sjn 0 = Air off probe Sjn 1 = Inlet probe S	0	-50	50	°C/F	NO		
r6	Control offset with probe error	0	0	1	-	NO		
r7	Master sensor valve configuration 0 = local valve, 1 = network valve (connected to Main)	0	0	20	°C/F	NO		
S1	Set point	50	r1	r2	°C/F	YES	30	-5
S2	Inlet probe set point with double thermostat	50	r1	r2	°C/F	NO		
r3	Differential	2	0.1	99.9	°C/F	YES	6	4
rC	Operating mode 0 = Direct, 1 = Reverse	0	0	1	-	NO		
rD2	Set point S2 differential with double thermostat 0.0 = function disabled	0	0	99.9	°C/F	NO		
rHS	Virtual probe composition for glass temp. probe estimate 0 = Air off probe Sjn 100 = Air on probe S	20	0	100	%	NO		
rHA	Coeff. A for glass temp. probe estimate	2	-20	20	°C/F	NO		
rHB	Coeff. B for glass temp. probe estimate	222	0	100	°C/F	NO		
rHb	Offset for anti-sweat modulation	2	-20	20	°C/F	NO		
rHu	Manual anti-sweat heater activation percentage (of period TH1) 0 = function disabled	70	0	100	%	NO		
rHt	Manual anti-sweat heater activation period	5	0	180	min	NO		
rLI	Max time for Clean status	0	0	999	min	NO		
rSL	Maximum time for Strobby status	0	0	240	min	NO		
rH4	Time light stays on after closing the door	0	0	240	min	NO		
rDS	Safety timeout for double thermostat function	0	0	240	min	NO		
db1	Double thermostat function logic 0 = AND logic, 1 = OR logic	0	0	1	-	NO		

Code	Description	Def	Min	Max	UOM	User Terminal	JNRBHS	JNRZSHA
<b>Digital outputs</b>								
DOA	Assign solenoid/compressor digital output 0 = not configured 1 = digital input 1 (DI1) 2 = digital output 2 (D2) 3 = digital input 3 (DI3) 4 = digital input 4 (DI4)	2	0	4	-	NO	3	3
DOB	Assign alarm digital output - see DOA	0	0	4	-	NO		
DOC	Assign auxiliary digital output - see DOA	0	0	4	-	NO		
DOE	Assign light digital output serving the Main on the Secondary devices - see DOA	4	0	4	-	NO	4	4
DOF	Assign defrost digital output - see DOA	0	0	4	-	NO		
DOH	Assign auxiliary evaporator defrost digital output - see DOA	1	0	4	-	NO	0	1
DOI	Assign second ON/OFF compressor digital output - see DOA	0	0	4	-	NO		
DOJ	Assign evaporator fan digital output - see DOA	3	0	4	-	NO	0	2
DOk	Assign digital output for liquid valve (pump down)	0	0	4	-	NO		
DOl	Assign lined digital output - see DOA	0	0	4	-	NO		
DOM	Assign drain heater digital output - see DOA	0	0	4	-	NO		
DOO	Assign anti-sweat heater digital output - see DOA	0	0	4	-	NO		
DOOA	Assign not gas defrost digital output - see DOA	0	0	4	-	NO		
DOOB	Assign digital output for max fan speed connection	0	0	4	-	NO		
DOOC	Assign digital output for min fan speed connection	0	0	4	-	NO		
DOOD	Assign digital output for max fan speed connection	0	0	4	-	NO		
DOOE	Assign digital output for min fan speed connection	0	0	4	-	NO		
DOOJ	Assign digital output for max fan speed connection	0	0	4	-	NO		
DOOK	Assign digital output for min fan speed connection	0	0	4	-	NO		
DOOL	Assign digital output for max fan speed connection	0	0	4	-	NO		
DOOM	Assign digital output for min fan speed connection	0	0	4	-	NO		
DOON	Auxiliary digital output logic - see /OA	0	0	1	-	NO		
DOOQ	Auxiliary serving the Main on the Secondary devices digital output logic - see /OA	0	0	1	-	NO		
DOOE	Light digital output logic - see /OA	0	0	1	-	NO		
DOOF	Light serving the Main on the Secondary devices digital output logic - see /OA	0	0	1	-	NO		
DOOG	Defrost digital output logic - see /OA	0	0	1	-	NO		
DOOH	Auxiliary evaporator fan digital output logic - see /OA	0	0	1	-	NO		
DOOI	Evaporator fan digital output logic - see /OA	0	0	1	-	NO		
DOOJ	Liquid valve digital output logic - see /OA	0	0	1	-	NO		
DOOK	Pump heater digital output logic - see /OA	0	0	1	-	NO		
DOOL	Anti-sweat heater digital output logic - see /OA	0	0	1	-	NO		
DOOM	Hot gas defrost digital output logic - see /OA	0	0	1	-	NO		
DOON	Minimum fan speed connection digital output logic - see /OA	0	0	1	-	NO		
DOOO	Output switched with time bands	0	0	1	-	NO		
DOOQ	Relay Type 0 = Light 1 = AUX	0	0	1	-	NO	0	0
DOOT1	Relay Type 0 = Light 1 = AUX	-	-	-	-	-	3	3
DOOT2	Relay Type 0 = Light 1 = AUX	-	-	-	-	-	3	3
DOOT3	Relay Type 0 = Light 1 = AUX	-	-	-	-	-	3	3
DOOT4	Relay Type 0 = Light 1 = AUX	-	-	-	-	-	3	3
<b>Digital Inputs</b>								
DI0	Assign start defrost digital input - see /OA	0	-1	2	-	NO	1	1

**Note:**  
For full parameter list and instructions, please refer to Carel's website  
<https://www.carel.com/documents/1019170/%2B0300106EN/aa0a64c-0dec-45b4-92b4-bc812d1fc3fa?version=1.0>

Code	DATE	ECN	NO	OR	DESCRIPTION
AKM 07/16/25	123680	3	EVAP FANS SETPOINT UPDATED		
AKM 11/14/24	123469	2	SETPOINT UPDATED FOR LIGHT		
AKM 07/25/24	122707	1	UPDATED PRODUCTION SETPOINT		
REV 07/19/24	122638	X	RELEASED TO PRODUCTION		

ALL BENDS 90° UNLESS SPECIFIED  
UNITS: INCHES - (MM)  
LOCAL DIMENSIONS (UNLESS NOTED)  
ALL ANGULAR DIM. IN DEGREES  
DIMENSIONS ON FORMERS TO 0.03  
DIMENSIONS ON FORMERS TO 0.05  
DRAWING NOT TO SCALE  
**Hilphoenix**  
Display Cases  
Manufactured in the USA  
© 2025 Hilphoenix, Inc.  
04/2025  
DRAWN BY: AKM DATE: 07/19/24


SETPOINTS: MPXzero  
2-5DR LI & MT,  
R290, DOLLAR-TREE

R905649

SHEET 1 OF 4

# D2: CONTROLLERS AND SETPOINTS

Code	Description	Def	Min	Max	UOM	User Terminal	JNRBHS	JNRZSHA
<b>Defrost</b>								
d0	Type of defrost 0 = heater by temperature 1 = hot gas by temperature 2 = heater by time 3 = hot gas by time 4 = temperature control with heater by time	0	0	4	-	S	YES	0 1
dEP	Assign probe for end defrost in advance 0 = Not configured 1 = Outlet (Sn) 2 = Defrost (Sd) 3 = Intake (Si) 4 = Defrost 2 (SDP) 5 = Auxiliary 1 (Saux1) 6 = Auxiliary 2 (Saux2) 7 = Ambient humidity (SU) 8 = Ambient humidity (SV) 9 = Glass temperature (Sv) 10 = Dew point (SDP) 11 = Virtual probe (Sv)	0	0	11	-	S	NO	
dET	Temperature threshold for end defrost in advance	50	99.9	99.9	°C	S	NO	
d2	End defrost synchronized by Main 0 = not synchronized, 1 = synchronized	1	0	1	-	S	NO	
d3	Send start network defrost signal (for Main) Ignore start network defrost signal (for Secondary) 0 = no, 1 = yes	0	0	1	-	S	NO	
d4	Maximum interval between consecutive defrosts	8	0	240	hours	S	YES	12 24
d5	End defrost temperature (read by Sd)	8	-50	50	°C/F	S	YES	40 72
dP1	Maximum defrost duration	45	1	240	min	S	YES	46 30
dP2	Max secondary evaporator defrost duration	45	1	240	min	S	NO	
d4	Defrost on power on (Main = network defrost; Secondary = local defrost) 0 = No, 1 = Yes	0	0	1	-	S	NO	
d5	Defrost delay at power-on or (for Secondary) after control signal from Main 0 = delay disabled	0	0	240	min	S	NO	
d6	Display on terminals during defrost 0 = temperature alternating with 'dEF' 1 = freeze display 2 = 'dEF'	1	0	2	-	U	NO	0 0
d7	Dripping time after defrost (fans off) 0 = no dripping	2	0	15	min	S	NO	0 0
d7	Skip defrost 0 = disabled, 1 = enabled	0	0	1	-	S	NO	
d8	Bypass high temperature alarm time after defrost	30	1	240	min	S	NO	
d9	Defrost priority over compressor protection times 0 = compressor protection times observed, 1 = compressor protection times ignored	1	0	1	-	M	NO	
d10	Defrost time in Running time mode 0 = function disabled	0	0	240	min	S	NO	
d11	Defrost temperature threshold in Running time mode 0 = pump down disabled 1 = function disabled	-30	-50	50	°C/F	S	NO	
dS1	Compressor off time in sequential stop defrost mode 0 = function disabled	0	0	999	s	M	NO	
dS2	Compressor operating time in power defrost mode 0 = function disabled	120	0	240	min	M	NO	
dD	Additional end defrost temperature delta in power defrost mode 0 = function disabled	0	-20	20	°C/F	S	NO	
dP	Additional maximum defrost time delta in power defrost mode 0 = function disabled	75	0	100	min	S	NO	
r3	Nominal defrost duration for skip defrost End defrost by timeout signal 0 = disabled, 1 = enabled	0	0	1	-	S	NO	
c7	Defrost priority over continuous cycle 0 = No, 1 = Yes	0	0	1	-	M	NO	
dD1	Assign probe 1 to determine start defrost (dD1-dD2) - see FSa	0	0	14	-	S	NO	
dD2	Assign probe 2 to determine start defrost (dD1-dD2) - see FSa	0	0	14	-	S	NO	
dTd	Temperature differential threshold to start defrost	50	99.9	99.9	°C	S	NO	
dDf	Threshold evaluation time to start defrost	60	15	240	Hz	S	NO	
dCf	Compressor frequency during hot gas defrost procedure	140	0	255	Hz	S	NO	
dHf	Compressor frequency during dripping phase after hot gas defrost	140	0	255	Hz	S	NO	
dHG	Hot gas activation delay	0	0	300	s	S	NO	

Code	Description	Def	Min	Max	UOM	User Terminal	JNRBHS	JNRZSHA
<b>Defrost scheduling</b>								
tdf1	Defrost 1 to 8 - day 0 = event disabled 1 to 7 = Monday to Sunday 8 = Monday to Friday 9 = from Monday to Saturday 10 = Saturday & Sunday 11 = every day	0	0	11	day	S	NO	0 11
tdf1	Defrost 1 to 8 - hours	0	0	23	hours	S	NO	
tdf1	Defrost 1 to 8 - minutes	0	0	59	minutes	S	NO	
tdf1	Defrost 1 to 8 - enable power defrost: 0 = normal, 1 = power defrost	0	0	1	-	S	NO	
dFS	Number of daily defrosts (dF1) 0 = Disabled 1 = 24 hours and 0 minutes 2 = 12 hours and 0 minutes 3 = 6 hours and 0 minutes 4 = 4 hours and 0 minutes 5 = 3 hours and 0 minutes 6 = 2 hours and 0 minutes 7 = 1 hour and 0 minutes 8 = 4 hours and 26 minutes	0	0	14	-	S	NO	
d2S	Number of daily defrosts (dD2) - see d1S	0	0	14	-	S	NO	
<b>Evaporator fans</b>								
F0	Evaporator fan management 0 = always on 1 = activation based on Sa - Sb (see FSa and FSh) 2 = activation based on Sa (Sa = first probe, Sb = second probe)	0	0	2	-	S	YES	0 2
F1	Evaporator fan activation threshold (only if F0 = 1 or 2)	-5	-50	50	°C/F	S	YES	30 40
F2	0 = see F0 1 = always off	1	0	1	-	S	YES	0 0
F3	Evaporator fans during defrost 0 = On, 1 = time after defrost (fans off with control active)	1	0	1	-	S	F3	0 1
F4	Fan setpoint differential (including variable speed)	2	0	15	min	S	NO	
F5	Evaporator fan cut-on temperature (hysteresis 1 °C)	2	0	20	°C/F	S	YES	
F6	Maximum evaporator fan speed	100	F7	100	%	M	NO	
F7	Minimum evaporator fan speed	0	0	P6	%	M	NO	
F8	Evaporator fan peak time 0 = evaporator fan forcing time at maximum speed	0	0	240	min	M	NO	
F10	Evaporator fan forcing time at maximum speed 0 = Function disabled	0	0	240	min	M	NO	
<b>FSa</b>								
First fan control probe								
0 = Not configured								
1 = Outlet (Sm)								
2 = Defrost (Sd)								
3 = Intake (Si)								
4 = Inlet (Sv)								
5 = Auxiliary 1 (Saux1)								
6 = Auxiliary 2 (Saux2)								
7 = Ambient humidity (SU)								
8 = Ambient humidity (SV)								
9 = Glass temperature (Sv)								
10 = Dew point (SDP)								
11 = Virtual probe (Sv)								
<b>FSb</b>								
Second fan control probe - see FSa								
0 = On, 1 = Off								
<b>Fpd</b>								
Evaporator fans during post-dripping								
0 = 0, 1 = 1								
<b>POM</b>								
Unit cooling capacity indication								
4000 0 32000 watts								
ALL BENDS 90° UNLESS SPECIFIED								
UNITS: INCHES - (MM)								
LOCALS: (0) ALL ANGULAR DIM. (1) FEET/INCH								
DIMENSIONS ON FORMS ARE TO FACE UNLESS NOTED OTHERWISE								
DRAWING NOT TO SCALE								
								
Display Cases AKM 07/16/25 123680 3 EVAP FANS SETPOINT UPDATED AKM 11/14/24 123469 2 SETPOINT UPDATED FOR LIGHT AKM 07/25/24 122707 1 UPDATED PRODUCTION SETPOINT REV 07/19/24 122638 X RELEASED TO PRODUCTION BY DATE ECN NO/REV DESCRIPTION								
SETPOINTS, MPXzero 2-5DR LT & MT, R290, DOLLAR-TREE							R905649	

# D3: CONTROLLERS AND SETPOINTS

Code	Description	Def	Min	Max	UOM	User Terminal	JNFBHSA	JNRZSHA
<b>Solenoid/compressor</b>								
c0	Delay to enable solenoid/compressor and evaporation fans at power-on	0	0	240	min	M	NO	
c1	Minimum time between consecutive compressor starts	0	0	15	min	M	NO	
c2	Minimum compressor OFF time	0	0	15	min	M	NO	5
c3	Minimum compressor ON time	0	0	15	min	M	NO	5
c4	ON time for duty setting operation (Toff = 15 minutes, fixed value) 0 = compressor always OFF 100 = compressor always ON	0	0	100	min	M	NO	
cc	Running time in continuous cycle	1	0	15	hours	M	NO	
c6	Low temperature alarm bypass time after continuous cycle	60	0	240	min	M	NO	
c11	Second compressor start delay	4	0	250	s	S	NO	
c12	Second compressor start mode 0 = delay at start and in normal control 1 = delay sta. start only	0	0	1	-	S	NO	
<b>Alarms</b>								
A0	High and low temp. alarm reset differential	2	0.1	20	°C/°F	S	YES	
A1	Alarm thresholds (AL, AH) relative to the set point (St) or absolute 0/1 = relative /absolute	0	0	1	-	S	NO	0
A2	Alarm thresholds (AL2, AH2) relative to the set point (St) or absolute 0/1 = relative /absolute	0	0	1	-	S	NO	
A6	Configure compressor operation during external alarm (immediate or delayed) with fixed 15 min OFF time 100 = always ON	0	0	100	min	S	NO	
A10	Configure solenoid/compressor control during external alarm (immediate or delayed) with fixed 15 min OFF time 100 = always ON	0	0	100	min	S	NO	
A11	Delay times for delayed external alarm 0 = Signal-only alarm 0 = Not configured	0	0	240	min	S	NO	
AA	Assign probe for high (AH/AHA) and low (AL/ALA) temperature alarms 0 = Not configured 1 = Outlet (Sm) 2 = Defrost (Sd) 3 = Intake (Sr) 4 = Defrost 2 (Sd2) 5 = Auxiliary 1 (Stux1) 6 = Auxiliary 2 (Stux2) 8 = Reservoir (SA) 9 = Glass temperature (Sv) 10 = Dewpoint (SdP) 11 = Virtual probe (Sv)	1	0	11	-	S	YES	
AA2	Assign probe for high (AH2/AHA2) and low (AL2/ALA2) temperature alarms - see AA	1	0	11	-	S	NO	
AL	Low temperature alarm threshold (relative to set point)	4	0	50	°C/°F	S	YES	6
ALA	Low temperature alarm threshold (absolute threshold)	0	-50	50	°C/°F	S	NO	
AH	High temperature alarm threshold (relative to set point)	10	0	50	°C/°F	S	YES	30
AHA	High temperature alarm threshold (absolute threshold)	0	-50	200	°C/°F	S	NO	69
AL2	Low temperature alarm threshold 2	0	0	50	°C/°F	S	NO	
AL2*	Low temperature alarm threshold 2 (absolute threshold)	0	-50	50	°C/°F	S	NO	
AH2	High temperature alarm threshold 2	0	0	50	°C/°F	S	NO	
AHA2*	High temperature alarm threshold 2 (absolute threshold)	0	-50	200	°C/°F	S	NO	
Ad	Delay time for high and low temperature alarms (AH/AHA, AL/ALA)	120	0	240	min	U	YES	
Ad2	Delay time for high and low temp. alarms (AH2/AHA2, AL2/ALA2)	30	1	240	min	U	NO	
Ar	Signal alarms from Secondary to Main 0 = not enabled, 1 = enabled	1	0	1	-	S	NO	
Add	High temperature alarm bypass time for door open	30	1	240	min	U	NO	
Tdoor	Door open: alarm delay	30	1	240	min	S	NO	
Hid	HACCP alarm delay 0 = monitoring disabled	0	0	240	min	S	NO	
Notice *: for alarms with an absolute activation threshold (A1±1) the thresholds ALA/ALA2 and AHA/AHA2 need to be set correctly, (default full scale, absolute alarms disabled).								

Code	Description	Def	Min	Max	UOM	User Terminal	JNFBHSA	JNRZSHA
<b>Connectivity</b>								
In	Type of unit 0 = Secondary, 1 = Main					S	YES	1
H0	Serial or Main/Secondary network address	199	0	247	-	S	YES	
H1	BMS serial port configuration (stop bits and parity) 0 = 1 stop bit, no parity 3 = 2 stop bits, even parity 2 = 2 stop bits, odd parity 4 = 2 stop bits, even parity 5 = 2 stop bits, odd parity	1	0	5	-	S	YES	
H2	BMS serial port baudrate (bits) 0 = 2400 1 = 4800 2 = 9600 3 = 19200 4 = 38400 5 = 57600 6 = 115200 7 = 115200	4	0	8	-	S	YES	
H3	BMS serial port protocol 0 = Carel, 1 = Modbus	1	0	1	-	S	YES	
<b>Fields</b>								
Sn	No. of slaves in the local network 0 = no Slaves	0	0	9	-	S	NO	
H4	FBus port baudrate (bits) 0 = 1200 1 = 2400 2 = 4800 3 = 9600 4 = 19200 5 = 38400 6 = 57600 7 = 115200	4	0	1	-	S	NO	
Notice: on fixed DEFAULT values for VCP serial								
<b>Display</b>								
/5	Unit of measure 0 = °C/barg, 1 = °F/psig	0	0	1	-	S	YES	1
/6	Display decimal point 0 = Yes, 1 = No	0	0	1	-	S	NO	1
/11	Display on user terminal 0 = Terminal disabled 1 to 3 = Probe 1 to 3 4 to 8 = Reserved 9 = Control probe	9	0	15	-	S	NO	
H5	Enable keypad and NFC functions 0 = Disabled, 1 = Enabled	1	0	1	-	U	NO	
H8	Buzzer 0 = No, 1 = Yes	1	0	1	-	U	NO	
ON	Unit On/Off command on display	1	0	1	-	S	NO	
ONK	Enable unit On/Off from display	1	0	1	-	S	NO	
ONS	Enable unit On/Off from supervisor	0	0	1	-	S	NO	
<b>Day/Night</b>								
ts1..8-d	Start time band 1 to 8 day; day - see (td1..8-d)	0	0	11	day	S	NO	11
ts1..8-hh	Start time band 1 to 8 day; hours	0	0	23	hours	S	NO	6
ts1..8-mm	Start time band 1 to 8 day; minutes	0	0	59	minutes	S	NO	6
te1..8-d	End time band 1 to 8 day; day - see (td1..8-d)	0	0	11	day	S	NO	11
te1..8-hh	End time band 1 to 8 day; hours	0	0	23	hours	S	NO	0
te1..8-mm	End time band 1 to 8 day; minutes	0	0	59	minutes	S	NO	0
ALL BENDS 90° UNLESS SPECIFIED								
UNITS: INCHES - (MM)								
DIMENSIONS: (UNLESS OTHERWISE SPECIFIED)								
ALL ANGULAR DIM. IN DEGREES								
DIMENSIONS ON FORMER REV. 0-03								
DRAWING NOT TO SCALE								
<b>HiPhoxx</b>								
Display Cases								
AKM 07/16/25	123680	3	EVAP FANS SETPOINT UPDATED					
AKM 11/14/24	123469	2	SETPOINT UPDATED FOR LIGHT					
AKM 07/25/24	122707	1	UPDATED PRODUCTION SETPOINT					
REV 07/19/24	122638	X	RELEASED TO PRODUCTION					
BY	DATE	ECN	NO/REV	DESCRIPTION				
DRAWN BY: AKM DATE: 07/19/24								
SETPOINTS: MPXzero								
2-5DR LI & MT								
R290, DOLLAR-TREE								
R905649								
SHEET 3 OF 4								



# D5: CONTROLLERS AND SETPOINTS

## Parameter table

Code	Description	Def	Min	Max	UOM	User Terminal	JNRBHS	JNRZSHA	MT 2.5 DR	LT 2.5 DR
<b>Analogue inputs</b>										
/P1	Type of probe, group 1 (S1, S2, S3) 0 = PT1000 Standard Range -50/150 °C 1 = NTC Standard Range -50/190 °C	1	0	1	-	S	YES			
/P5	Configuration of analogue output Y1: 0 = 0-10 V, 6 = PWM	6	0	6	-	S	NO			
/P6	Configuration of analogue output Y2: 0 = 0-10 V, 6 = PWM	6	0	6	-	S	NO			
/FA	0 = Serial probe S11 1 = Serial probe S12 2 = Serial probe S13 3 = Serial probe S14	1	-4	3	-	S	YES	1	1	
/Fb	Assign defrost temperature probe (S1) - see /FA	2	-4	3	-	S	YES	2	2	0
/Fc	Assign defrost temperature probe (S2) - see /FA	3	-4	3	-	S	YES	0	0	
/Ff	Assign defrost temperature probe 2 (S2d) - see /FA	0	-4	3	-	S	NO			
/Fg	Assign auxiliary temperature/pressure probe 1 (Saux1) - see /FA	0	-4	3	-	S	NO			
/Fh	Assign auxiliary temperature/pressure probe 2 (Saux2) - see /FA	0	-4	3	-	S	NO			
/Fi	Assign ambient temperature probe (SA) - see /FA	0	-4	3	-	S	NO			
/Fj	Assign ambient humidity probe (SU) - see /FA	0	-4	3	-	S	NO			
/Fk	Assign dewpoint value (SP) - see /FA	0	-4	3	-	S	NO			
/Fa	Outlet temperature probe (Sm) calibration	0	-20	20	°C/F	S	NO			
/Fb	Inlet temperature probe (Sj) calibration	0	-20	20	°C/F	S	NO			
/Ff	Defrost temperature probe 2 (S2d) calibration	0	-20	20	°C/F	S	NO			
/Fg	Auxiliary temperature/pressure probe 1 (Saux1) calibration	0	-20	20	°C/F	S	NO			
/Fh	Auxiliary temperature/pressure probe 2 (Saux2) calibration	0	-20	20	°C/F	S	NO			
/Fi	Ambient temperature probe (SA) calibration	0	-20	20	°C/F	S	NO			
/Fj	Ambient humidity probe (SU) calibration	0	-20	20	°C/F	S	NO			
/Fk	Dewpoint value (SP) calibration	0	-20	20	°C/F	S	NO			
/Fm	Condenser temperature probe calibration	0	-20	20	°C/F	M	NO			
/Fz	Analogue probe measurement stability	9	1	15	-	M	NO			

Control	Description	Def	Min	Max	UOM	User Terminal	JNRBHS	JNRZSHA	MT 2.5 DR	LT 2.5 DR
ON	ON/OFF command 0 = OFF, 1 = ON	0	0	1	-	S	YES			
/A	Virtual probe composition 0 = Air off probe S1 100 = Air on probe S1	0	0	100	%	S	NO			
/Z	Minimum set point	-50	-50	72	°C/F	M	NO	25	-25	
/Z	Maximum set point	50	71	200	°C/F	M	NO	80	80	
/r4	Automatic night set point variation 0 = no night probe Sv, 1 = in take probe Sv	0	-50	50	°C/F	S	NO			
r6	Control offset with probe error	0	0	1	-	S	NO			
r0	Master sensor valve configuration 0 = local valve, 1 = network valve (connected to Main)	0	0	20	°C/F	S	NO			
r7	Set point	50	r1	r2	°C/F	U	YES	30	-9	
S2	In take probe set point with double thermostat	50	r1	r2	°C/F	S	NO			
r0	Differential	2	0.1	99.9	°C/F	U	YES	6	4	
rC	Operating mode 0 = Direct, 1 = Reverse	0	0	1	-	U	NO			
r02	Set point S2 differential with double thermostat 0.0 = function disabled	0	0	99.9	°C/F	S	NO			
rHS	Virtual probe composition for glass temp. probe estimate 0 = Air off probe S1 100 = Air on probe S1	20	0	100	%	S	NO			
rHA	Coeff. A for glass temp. probe estimate	2	-20	20	°C/F	S	NO			
rHB	Coeff. B for glass temp. probe estimate	222	0	100	°C/F	S	NO			
rHB	Offset for anti-sweat modulation	2	-20	20	°C/F	S	NO			
rHu	Manual anti-sweat heater activation percentage (of period TH1) 0 = function disabled	70	0	100	%	S	NO			
rHt	Manual anti-sweat heater activation period 0 = function disabled	5	0	180	min	S	NO			
CLT	Max time for Clean status	0	0	999	min	U	NO			
SLT	Maximum time for Standby status	0	0	240	min	S	NO			
H14	Time light stays on after closing the door	0	0	240	min	U	NO			
dbS	Safety timeout for double thermostat function	0	0	240	min	M	NO			
db1	Double thermostat function logic 0 = AND logic, 1 = OR logic	0	0	1	-	M	NO			

Code	Description	Def	Min	Max	UOM	User Terminal	JNRBHS	JNRZSHA	MT 2.5 DR	LT 2.5 DR
<b>Digital outputs</b>										
DOA	Assign solenoid/compressor digital output 0 = not configured 1 = digital input 1 (DI1) 2 = digital output 2 (D2) 3 = digital input 3 (DI3) 4 = digital input 4 (DI4)	2	0	4	-	S	NO	3	3	
DOB	Assign alarm digital output - see DOA	0	0	4	-	S	NO			
DOC	Assign auxiliary digital output - see DOA	0	0	4	-	S	NO			
DOE	Assign light digital output serving the Main on the Secondary devices - see DOA	4	0	4	-	S	NO	4	4	
DOF	Assign defrost digital output - see DOA	0	0	4	-	S	NO			
DOG	Assign defrost digital output - see DOA	1	0	4	-	S	NO	0	1	
DOH	Assign auxiliary evaporator defrost digital output - see DOA	0	0	4	-	S	NO			
DOI	Assign second ON/OFF compressor digital output - see DOA	0	0	4	-	S	NO			
DOJ	Assign evaporator fan digital output - see DOA	3	0	4	-	M	NO	0	2	
DOk	Assign digital output for liquid valve (pump down)	0	0	4	-	S	NO			
DOl	Assign lined digital output - see DOA	0	0	4	-	M	NO			
DOM	Assign drain heater digital output - see DOA	0	0	4	-	M	NO	0	0	
DOO	Assign anti-sweat heater digital output - see DOA	0	0	4	-	S	NO			
DOOA	Assign not gas defrost digital output - see DOA	0	0	4	-	M	NO			
DOO	Assign digital output for max fan speed connection	0	0	4	-	M	NO			
DOU	Assign digital output for min fan speed connection	0	0	4	-	M	NO			
DOV	Assign digital output for fan speed connection	0	0	4	-	M	NO			
DOX	Assign digital output for fan speed connection	0	0	4	-	M	NO			
DOY	Assign digital output for fan speed connection	0	0	4	-	M	NO			
DOZ	Assign digital output for fan speed connection	0	0	4	-	M	NO			
DO1	Assign digital output logic - see DOA	0	0	1	-	M	NO			
DO2	Assign digital output logic - see DOA	0	0	1	-	M	NO			
DO3	Assign digital output logic - see DOA	0	0	1	-	M	NO			
DO4	Assign digital output logic - see DOA	0	0	1	-	M	NO			
DO5	Assign digital output logic - see DOA	0	0	1	-	M	NO			
DO6	Assign digital output logic - see DOA	0	0	1	-	M	NO			
DO7	Assign digital output logic - see DOA	0	0	1	-	M	NO			
DO8	Assign digital output logic - see DOA	0	0	1	-	M	NO			
DO9	Assign digital output logic - see DOA	0	0	1	-	M	NO			
DO10	Assign digital output logic - see DOA	0	0	1	-	M	NO			
DO11	Assign digital output logic - see DOA	0	0	1	-	M	NO			
DO12	Assign digital output logic - see DOA	0	0	1	-	M	NO			
DO13	Assign digital output logic - see DOA	0	0	1	-	M	NO			
DO14	Assign digital output logic - see DOA	0	0	1	-	M	NO			
DO15	Assign digital output logic - see DOA	0	0	1	-	M	NO			
DO16	Assign digital output logic - see DOA	0	0	1	-	M	NO			
DO17	Assign digital output logic - see DOA	0	0	1	-	M	NO			
DO18	Assign digital output logic - see DOA	0	0	1	-	M	NO			
DO19	Assign digital output logic - see DOA	0	0	1	-	M	NO			
DO20	Assign digital output logic - see DOA	0	0	1	-	M	NO			
DO21	Assign digital output logic - see DOA	0	0	1	-	M	NO			
DO22	Assign digital output logic - see DOA	0	0	1	-	M	NO			
DO23	Assign digital output logic - see DOA	0	0	1	-	M	NO			
DO24	Assign digital output logic - see DOA	0	0	1	-	M	NO			
DO25	Assign digital output logic - see DOA	0	0	1	-	M	NO			
DO26	Assign digital output logic - see DOA	0	0	1	-	M	NO			
DO27	Assign digital output logic - see DOA	0	0	1	-	M	NO			
DO28	Assign digital output logic - see DOA	0	0	1	-	M	NO			
DO29	Assign digital output logic - see DOA	0	0	1	-	M	NO			
DO30	Assign digital output logic - see DOA	0	0	1	-	M	NO			
DO31	Assign digital output logic - see DOA	0	0	1	-	M	NO			
DO32	Assign digital output logic - see DOA	0	0	1	-	M	NO			
DO33	Assign digital output logic - see DOA	0	0	1	-	M	NO			
DO34	Assign digital output logic - see DOA	0	0	1	-	M	NO			
DO35	Assign digital output logic - see DOA	0	0	1	-	M	NO			
DO36	Assign digital output logic - see DOA	0	0	1	-	M	NO			
DO37	Assign digital output logic - see DOA	0	0	1	-	M	NO			
DO38	Assign digital output logic - see DOA	0	0	1	-	M	NO			
DO39	Assign digital output logic - see DOA	0	0	1	-	M	NO			
DO40	Assign digital output logic - see DOA	0	0	1	-	M	NO			
DO41	Assign digital output logic - see DOA	0	0	1	-	M	NO			
DO42	Assign digital output logic - see DOA	0	0	1	-	M	NO			
DO43	Assign digital output logic - see DOA	0	0	1	-	M	NO			
DO44	Assign digital output logic - see DOA	0	0	1	-	M	NO			
DO45	Assign digital output logic - see DOA	0	0	1	-	M	NO			
DO46	Assign digital output logic - see DOA	0	0	1	-	M	NO			
DO47	Assign digital output logic - see DOA	0	0	1	-	M	NO			
DO48	Assign digital output logic - see DOA	0	0	1	-	M	NO			
DO49	Assign digital output logic - see DOA	0	0	1	-	M	NO			
DO50	Assign digital output logic - see DOA	0	0	1	-	M	NO			
DO51	Assign digital output logic - see DOA	0	0	1	-	M	NO			
DO52	Assign digital output logic - see DOA	0	0	1	-	M	NO			
DO53	Assign digital output logic - see DOA	0	0	1	-	M	NO			
DO54	Assign digital output logic - see DOA	0	0	1	-	M	NO			
DO55	Assign digital output logic - see DOA	0	0	1	-	M	NO			
DO56	Assign digital output logic - see DOA	0	0	1	-	M	NO			
DO57	Assign digital output logic - see DOA	0	0	1	-	M	NO			
DO58	Assign digital output logic - see DOA	0	0	1	-	M	NO			
DO59	Assign digital output logic - see DOA	0	0	1	-	M	NO			
DO60	Assign digital output logic - see DOA	0	0	1	-	M	NO			
DO61	Assign digital output logic - see DOA	0	0	1	-	M	NO			
DO62	Assign digital output logic - see DOA	0	0	1	-	M	NO			
DO63	Assign digital output logic - see DOA	0	0	1	-	M	NO			
DO64	Assign digital output logic - see DOA	0	0	1	-	M	NO			
DO65	Assign digital output logic - see DOA	0	0	1	-	M	NO			
DO66	Assign digital output logic - see DOA	0	0	1	-	M	NO			
DO67	Assign digital output logic - see DOA	0	0	1	-	M	NO			
DO68	Assign digital output logic - see DOA	0	0	1	-	M	NO			
DO69	Assign digital output logic - see DOA	0	0	1	-	M	NO			
DO70	Assign digital output logic									

# D6: CONTROLLERS AND SETPOINTS

Code	Description	Def	Min	Max	UOM	User	Terminal	JNRBHS	JNRZSHA
<b>Defrost scheduling</b>									
dt1	Defrost 1 to 8 - day 0 = event disabled 1 to 7 = Monday to Sunday 8 = Monday to Friday 9 = from Monday to Saturday 10 = Saturday & Sunday 11 = every day	0	0	11	day	S	NO	0	11
dt1..8-hh	Defrost 1 to 8 - hours	0	0	23	hours	S	NO	0	3
dt1..8-mm	Defrost 1 to 8 - minutes	0	0	59	minutes	S	NO		
dt1..8-P	Defrost 1 to 8 - power defrost: 0 = normal, 1 = power defrost	0	0	1	-	S	NO		
dTS	Number of daily defrosts (d1) 0 = Disabled 1 = 24 hours and 0 Minutes 2 = 12 hours and 0 Minutes 3 = 8 hours and 0 Minutes 4 = 6 hours and 0 Minutes 5 = 4 hours and 0 Minutes 6 = 4 hours and 0 Minutes 7 = 3 hours and 26 Minutes	0	0	14	-	S	NO		
d2S	Number of daily defrosts (d2) - see d1S	0	0	14	-	S	NO		
<b>Evaporator fans</b>									
F0	Evaporator fan management 0 = always on 1 = activation based on Sa - Sb (see F5a and F5b) 2 = activation based on Sa (Sa = first probe, Sb = second probe)	0	0	2	-	S	YES	0	2
F1	Evaporator fan activation threshold (only if F0 = 1 or 2)	-5	-50	50	°C/F	S	YES	30	40
F2	Evaporator fans with compressor off 0 = see F0 1 = always off	1	0	1	-	S	YES	0	0
F3	Evaporator fans during defrost (on, 1 = on time after defrost (fans off with control active))	1	0	1	-	S	F3	0	1
F4	Post-opping time after defrost (fans off with control active)	2	0	15	min	S	NO		
F5	Fan activation differential (including variable speed)	2	0.1	20	°C/F	S	YES		
F6	Evaporator fan cut-off temperature (by default 1°C)	100	F1	50	°C/F	S	NO		
F7	Maximum evaporator fan speed	100	F7	100	%	M	NO		
F8	Minimum evaporator fan speed	0	0	F8	%	M	NO		
F9	Evaporator fan peak time	0	0	240	min	M	NO		
F10	Evaporator fan forcing time at maximum speed 0 = Function disabled	0	0	240	min	M	NO		
F11	First fan control probe 0 = Not configured 1 = Outlet (Sn) 2 = Defrost (Sd) 3 = Inlet (S1) 4 = Inlet (S2) 5 = Auxiliary 1 (Sau1) 6 = Auxiliary 2 (Sau2) 7 = Ambient (SA) 8 = Ambient humidity (SU) 9 = Glass temperature (SM) 10 = Dew point (SP) 11 = Virtual probe (Sv)	2	0	11	-	M	NO		
F5a	Evaporator fans during post-defrosting 0 = On, 1 = Off	11	0	11	-	M	NO		
F5b	Second fan control probe - see F5a	0	0	1	-	M	NO		
F5d	Unit cooling capacity indication	4000	0	32000	watts	M	NO		

Code	Description	Def	Min	Max	UOM	User	Terminal	JNRBHS	JNRZSHA
<b>Defrost</b>									
d0	Type of defrost 0 = heater by temperature 1 = hot gas by temperature 2 = heater by time 3 = hot gas by time 4 = temperature control with heater by time	0	0	4	-	S	YES	0	1
dEP	Assign probe for end defrost in advance 0 = Not configured 1 = Outlet (Sn) 2 = Defrost (Sd) 3 = Inlet (S1) 4 = Defrost 2 (Sd2) 5 = Auxiliary 1 (Sau1) 6 = Auxiliary 2 (Sau2) 7 = Ambient (SA) 8 = Ambient humidity (SU) 9 = Glass temperature (SM) 10 = Dew point (SP) 11 = Virtual probe (Sv)	0	0	11	-	S	NO		
dET	Temperature threshold for end defrost in advance	50	99.9	99.9	°C	S	NO		
d2	End defrost synchronized by Main 0 = not synchronized, 1 = synchronized	1	0	1	-	S	NO		
d3	Send start network defrost signal (for Main) 0 = ignore start network defrost signal (for Secondary) 0 = no, 1 = yes	0	0	1	-	S	NO		
d4	Maximum interval between consecutive defrosts	8	0	240	hours	S	YES	12	24
d5	End defrost temperature (read by Sd)	8	-50	50	°C/F	S	YES	40	72
dP1	Maximum defrost duration	45	1	240	min	S	YES	46	30
dP2	Max secondary evaporator defrost duration	45	1	240	min	S	NO		
d4	Defrost on power on (Main = network defrost; Secondary = local defrost) 0 = No, 1 = Yes	0	0	1	-	S	NO		
d5	Defrost delay at power-on or (for Secondary) after control signal 0 = delay disabled	0	0	240	min	S	NO		
d6	Display on terminals during defrost 0 = temperature alternating with dEF 1 = freeze display 2 = dEF	1	0	2	-	U	NO	0	0
d6	Dripping time after defrost (fans off) 0 = no dripping	2	0	15	min	S	NO	0	0
d7	Skip defrost 0 = disabled, 1 = enabled	0	0	1	-	S	NO		
d8	Bypass high temperature alarm time after defrost	30	1	240	min	S	NO		
d9	Defrost priority over compressor protection times 0 = compressor protection times observed, 1 = compressor protection times ignored	1	0	1	-	M	NO		
d10	Defrost time in Running time mode	0	0	240	min	S	NO		
d11	Defrost temperature threshold in Running time mode 0 = pump down disabled	-30	-50	50	°C/F	S	NO		
dH1	Pump down duration	0	0	999	s	M	NO		
dS1	Compressor off time in sequential stop defrost mode 0 = function disabled	0	0	45	min	M	NO		
dS2	Compressor operating time in sequential stop defrost mode	120	0	240	min	M	NO		
dD	Additional end defrost temperature delta in power defrost mode	0	-20	20	°C/F	S	NO		
dP	Additional maximum defrost time delta in power defrost mode	75	0	100	%	S	NO		
dN	Nominal defrost duration for skip defrost End defrost by timeout signal 0 = disabled, 1 = enabled	0	0	1	-	S	NO		
c7	Defrost priority over continuous cycle 0 = No, 1 = Yes	0	0	1	-	M	NO		
dd1	Assign probe 1 to determine start defrost (d1-d2) - see F5a	0	0	14	-	S	NO		
dd2	Assign probe 2 to determine start defrost (d1-d2) - see F5a	0	0	14	-	S	NO		
td	Temperature differential threshold to start defrost	50	99.9	99.9	°C	S	NO		
td	Threshold evaluation time to start defrost	60	15	240	min	S	NO		
cd	Compressor frequency during hot gas defrost procedure	140	0	255	Hz	S	NO		
cd	Compressor frequency during dripping phase after hot gas defrost	140	0	255	Hz	S	NO		
dHG	Hot gas activation delay	0	0	300	s	S	NO		

SETPOINTS: MPX0.2-5DR LT & MT, R290, BETA CASE, STD WITH LIGHTING SCHEDULE

Display Cases  
Copyright © 2016  
Hilphoenix  
11000 W. 10th Street, Suite 100, Omaha, NE 68144, USA  
www.hilphoenix.com

ALL BENDS 90° UNLESS SPECIFIED  
UNITS: INCHES - (MM)  
DIMENSIONS: (ALL DIMENSIONS UNLESS OTHERWISE SPECIFIED)  
DIMENSIONS OF FORMED PARTS TO BE TO DIMENSIONS OF FORMED PARTS UNLESS OTHERWISE SPECIFIED  
DRAWING NOT TO SCALE

REV: 01/16/25 12:36:80 X RELEASED TO PRODUCTION  
BY: DATE ECN NO/REV DESCRIPTION

R908294  
SHEET 2 OF 4

# D7: CONTROLLERS AND SETPOINTS

Code	Description	Def	Min	Max	UOM	User Terminal	JNRB/MT	JNRZ/DR	JNRZ/SHA
<b>Solenoid/compressor</b>									
c0	Delay to enable solenoid/compressor and evaporation fans at power-on	0	0	240	min	M	NO		
c1	Minimum time between consecutive compressor starts	0	0	15	min	M	NO	5	5
c2	Minimum compressor OFF time	0	0	15	min	M	NO	5	5
c3	Minimum compressor ON time	0	0	15	min	M	NO	5	5
c4	ON time for duty setting operation (Toff = 15 minutes, fixed value) 0 = compressive/valve always OFF 100 = compressive/valve always ON	0	0	100	min	M	NO		
cc	Running time in continuous cycle 0 = Disabled	1	0	15	hours	M	NO		
c6	Low temperature alarm bypass time after continuous cycle	60	0	240	min	M	NO		
c11	Second compressor start delay	4	0	250	s	M	NO		
c12	Second compressor start mode 0 = delay at start and in normal control 1 = delay sta start only	0	0	1	-	S	NO		

Code	Description	Def	Min	Max	UOM	User Terminal	JNRB/MT	JNRZ/DR	JNRZ/SHA
<b>Alarms</b>									
A0	High and low temp. alarm reset differential	2	0.1	20	°C/°F	S	YES		
A1	Alarm thresholds (AL, AH) relative to the set point SI or absolute 0/1 = relative/absolute	0	0	1	-	S	NO	0	0
A2	Alarm thresholds (AL2, AH2) relative to the set point S12 or absolute 0/1 = relative/absolute	0	0	1	-	S	NO		
A6	Configure compressor operation during external alarm (immediate or delayed) with fixed 15 min OFF time 0 = always OFF 100 = always ON	0	0	100	min	S	NO		
A10	Configure solenoid/compressor control during external alarm (immediate or delayed) with fixed 15 min OFF time 0 = always OFF 100 = always ON	0	0	100	min	S	NO		
A11	Delay time for delayed external alarm 0 = Signal-only alarm	0	0	240	min	S	NO		
AA	Assign probe for high (AH/AHA) and low (AL/ALA) temperature alarms 0 = Not configured 1 = Outlet (Sm) 2 = Defrost (Sd) 3 = Intake (St) 4 = Defrost 2 (Sd2) 5 = Auxiliary 1 (Saux1) 6 = Auxiliary 2 (Saux2) 7 = Sensor (Sh) 8 = Reseal 9 = Glass temperature (Sv4) 10 = Dewpoint (SdP) 11 = Virtual probe (Sv)	1	0	11	-	S	YES		
A42	Assign probe for high (AH2, AHA2) and low (AL2, ALA2) temperature alarms - see AA	1	0	11	-	S	NO		
AL*	Low temperature alarm threshold (relative to set point)	4	0	50	°C/°F	S	YES	6	6
ALH*	Low temperature alarm threshold (absolute threshold)	0	-50	50	°C/°F	S	NO		
AHA*	High temperature alarm threshold (relative to set point)	10	0	50	°C/°F	S	YES	30	69
AHA2*	High temperature alarm threshold (absolute threshold)	0	-50	200	°C/°F	S	NO		
AL2*	Low temperature alarm threshold 2 (absolute threshold)	0	-50	50	°C/°F	S	NO		
AH2*	High temperature alarm threshold 2 (absolute threshold)	0	50	200	°C/°F	S	NO		
AHA2*	High temperature alarm threshold 2 (absolute threshold)	0	-50	200	°C/°F	S	NO		
A4	Delay time for high and low temperature alarms (AH/AHA, AL/ALA)	120	0	240	min	U	YES		
A42	Delay time for high and low temp. alarms (AH2/AHA2, AL2/ALA2)	30	1	240	min	U	NO		
A1	Signal alarms from Secondary to Main 0 = not enabled, 1 = enabled	1	0	1	-	S	NO		
Add	High temperature alarm bypass time for door open	30	1	240	min	U	NO		
Door	Door open; alarm delay	30	1	240	min	S	NO		
H10	HACCP alarm delay 0 = nonotifying disabled	0	0	240	min	S	NO		

Notice \*: for alarms with an absolute activation threshold (A1=1) the thresholds ALA/ALA2 and AHA/AHA2 need to be set correctly (default full scale, absolute alarms disabled).

Code	Description	Def	Min	Max	UOM	User Terminal	JNRB/MT	JNRZ/DR	JNRZ/SHA
<b>Connectivity</b>									
In	Type of unit 0 = Secondary, 1 = Main	0	0	1	-	S	YES	1	1
H0	Serial or Main/Secondary network address	169	0	247	-	S	YES		
H1	BMS serial port configuration (stop bits and parity) 0 = 1 stop bit, no parity 1 = 2 stop bits, even parity 2 = 4 stop bits, no parity 3 = 4 stop bits, odd parity 4 = 1 stop bit, even parity 5 = 2 stop bits, odd parity	1	0	5	-	S	YES		
H2	BMS serial port baudrate (bits) 0 = 9600 1 = 2400 2 = 4800 3 = 9600 4 = 19200 5 = 38400 6 = 57600 7 = 115200	4	0	8	-	S	YES		
H3	BMS serial port protocol 0 = Carel, 1 = Modbus	1	0	1	-	S	YES		

Code	Description	Def	Min	Max	UOM	User Terminal	JNRB/MT	JNRZ/DR	JNRZ/SHA
<b>Fieldsbus</b>									
Sn	No. of slaves in the local network 0 = no Slaves	0	0	9	-	S	NO		
H4	FBus port baudrate (bits) 0 = 1200 1 = 2400 2 = 4800 3 = 9600 4 = 19200 5 = 38400 6 = 57600 7 = 115200	4	0	1	-	S	NO		

Notice: on fixed DEFAULT values for VCP serial

Code	Description	Def	Min	Max	UOM	User Terminal	JNRB/MT	JNRZ/DR	JNRZ/SHA
<b>Display</b>									
/5	Unit of measure 0 = °C/hg, 1 = °F/sig	0	0	1	-	S	YES	1	1
/6	Display decimal point 0 = Yes, 1 = No	0	0	1	-	S	NO	1	1
/11	Display on user terminal 0 = Terminal disabled 1 to 3 = Probe 1 to 3 4 to 8 = Reserved 9 = Control probe	9	0	15	-	S	NO		
H5	Enable keypad and NFC functions 0 = Disabled, 1 = Enabled	1	0	1	-	U	NO		
H8	Buzzer 0 = No, 1 = Yes	1	0	1	-	U	NO		
ON	Unit On/Off command on display	1	0	1	-	S	NO		
ONK	Enable unit On/Off from display	1	0	1	-	S	NO		
ONS	Enable unit On/Off from supervisor	0	0	1	-	S	NO		

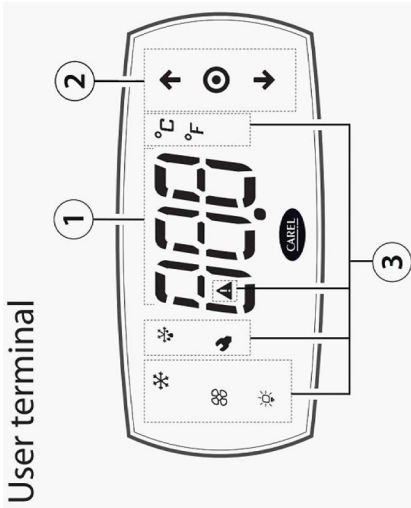
Code	Description	Def	Min	Max	UOM	User Terminal	JNRB/MT	JNRZ/DR	JNRZ/SHA
<b>Day/Night</b>									
/s1..8-d	Start time band 1 to 8 day/day - see (dt1...8-d)	0	0	11	day	S	NO	11	11
/s1..8-hh	Start time band 1 to 8 day; hours	0	0	23	hours	S	NO	6	6
/s1..8-mm	Start time band 1 to 8 day; minutes	0	0	59	minutes	S	NO		
/e1..8-d	End time band 1 to 8 day/day - see (dt1...8-d)	0	0	11	day	S	NO	11	11
/e1..8-hh	End time band 1 to 8 day; hours	0	0	23	hours	S	NO	0	0
/e1..8-mm	End time band 1 to 8 day; minutes	0	0	59	minutes	S	NO		

ALL BENDS 90° UNLESS SPECIFIED  
UNITS: (INCHES - (MM))  
LOCATIONS: (0 = FIELD)  
ALL ANGULAR DIM. (°)  
DIMENSIONS ON FORMS ARE 0.0  
UNLESS NOTED OTHERWISE. UNITS ARE IN  
DRAWING NOT TO SCALE.  
**Hilphoenix**  
Display Cases  
Glenfield, WI 53126  
www.hilphoenix.com

SETPOINTS: MPX0.2 - 5DR LT & MT, R290, BETA CASE, STD WITH LIGHTING SCHEDULE  
R908294  
DRAWN BY: AKM DATE: 01/16/25  
SHEET 3 OF 4

REV: 01/16/25 12:36:00 RELEASED TO PRODUCTION  
BY: DATE ECN NO/REV DESCRIPTION

Parameter categories visible on the user terminal



Procedure: To navigate the menu, use the following buttons:

- UP and DOWN to navigate the menu and set the values;
- PRG to enter the menu items and save the changes made;
- ESC to select the menu item or ESC to return to the previous branch. Example of how to set parameter St (set point):

- Wait for the standard display to be shown.
- Press PRG, the display will show 'Loc' (display locked).
- Press and hold PRG and until 'PSR' is shown.
- Press PRG, the first category of parameters is displayed.
- Press PRG, the second category of parameters is displayed.
- Press PRG, the second category of parameters is displayed.
- Press PRG, the second category of parameters is displayed.
- Press PRG, the second category of parameters is displayed.
- Press PRG, the second category of parameters is displayed.
- Press PRG, the second category of parameters is displayed.
- Press PRG, the second category of parameters is displayed.
- Press PRG, the second category of parameters is displayed.

**Mobile device and PC**

The 'APPLICA' app and 'SPARK' software can be used to configure the controller from a mobile device (smartphone, tablet), via NFC (Near Field Communication) or Bluetooth. The controller can be programmed according to the profile used for access to APPLICA or SPARK, with different parameter visibility depending on the rights associated with each profile (User, Service, Manufacturer). Procedure:

- download the 'APPLICA' app;
- on the mobile device start the app for commissioning the controller;
- activate NFC or Bluetooth on the mobile device;
- activate APPLICA or SPARK on the mobile device;
- follow the instructions shown on the display.

**3.2.5 Direct functions**

The following functions can be activated directly from the keypad or via the app:

Icon	Display	On/off
☼	UIT	Cabinet light
⌚	Cnt	Continuous cycle
⚙️	dEF	Default
🌐	dFn	Network default (Main only)
🗑️	CLn	Clear cabinet
⚡	ON	Unit ON with control request

Tab. 3.h

Procedure:

- go to the standard display,
- press PRG until "--" is shown and then release immediately to unlock the display
- press PRG again to access the direct commands (the first item will be the light command Lht);
- press PRG to turn the light on/off and DOWN to move to the next direct function;
- follow the previous steps for all the other functions;
- When finished, press Esc to exit.

**3.2.2 Display**

The icons provide information on device operation and/or the activation of certain functions, as shown in the table.

Icon	Function	On
🐟	Fishing	
⚙️	Compressor	Compressor times active
⚙️	Compressor	Compressor times active
⚙️	Expansor fan	Expansor fan on
💡	Lights	Light on
⚙️	Defrost	Defrost active
⚙️	Service	Maintenance request
⚙️	Alarm	Alarm acknowledged
⚙️	Alarm	Alarm active
°C	Unit of measure degrees Celsius	Unit of measure °C
°F	Unit of measurement degrees Fahrenheit	Unit of measure °F

Tab. 3.k

**3.2.1 Keypad**

Button	Description	Function
↑	UP / DOWN	<ul style="list-style-type: none"> <li>Increase/decrease the value</li> <li>Scroll direct access functions</li> <li>LED on: scroll menu parameters, direct access functions</li> </ul>
⌚	PRG	<ul style="list-style-type: none"> <li>Pressed briefly: set parameter values</li> <li>Save value and return to the parameter code</li> <li>Mute buzzer</li> <li>Pressed and held (hold unit "--" is shown):</li> <li>Enter direct access function menu (from main screen) and activate/deactivate functions</li> <li>Pressed and held (hold after "--" is shown):</li> <li>Enter programming mode or return to previous level without saving</li> <li>LED on: main screen/programming mode</li> </ul>

ⓘ Notice: when scrolling, a button is enabled only when illuminated.

- Go to the standard display,
- Press PRG until "--" is displayed and then release immediately.
- Press PRG again. Lht is displayed, the UP and DOWN buttons light up. Press PRG to turn the light on/off. The icon will come on or go off. Press DOWN to activate the next function (Cnt) or press Esc to exit.
- Select Esc to exit
- The standard display is shown

ALL BENDS 90° UNLESS SPECIFIED	INCHES - (MM)
UNITS:	
DEVIATION (°):	
ALL ANGULAR DIM. (°):	
ALL DIMENSIONS ON FORMED TUBES TO BE TO DIMENSIONS OF FORMED TUBES TO BE DRAWING, NOT TO SCALE	
<b>Hilphoenix</b>	
Display Cases Manufactured in Italy Distributors: Hilphoenix S.p.A. - Via S. Maria Maddalena, 10 - 00187 Roma, Italy Tel. +39 06 490101 - Fax +39 06 49010200 - Email: info@hilphoenix.it	
DATE: 01/16/25	DRAWN BY: AKM
REV: 01/16/25	RELEASED TO PRODUCTION
BY:	DESCRIPTION

SETPOINTS: MPX0,2-5DR, LT & MT, R290, BETA CASE, STD WITH LIGHTING SCHEDULE

R908294

SHEET 4 OF 4

# D9: CONTROLLERS AND SETPOINTS

## Parameter table

Code	Description	Def	Min	Max	UOM	User Terminal	JNRBHS	JNRZSHA
<b>Analogue inputs</b>								
/P1	Type of probe, group 1 (S1, S2, S3) 0 = PT1000 Standard Range -50/150 °C 1 = NTC Standard Range -50/90 °C	1	0	1	-	S	YES	
/P5	Configuration of analogue output Y1: 0 = 0-10 V, 6 = PWM	6	0	6	-	S	NO	
/P6	Configuration of analogue output Y2: 0 = 0-10 V, 6 = PWM	6	0	6	-	S	NO	
/FA	0 = Serial probe S11 1 = Serial probe S12 2 = Serial probe S13 3 = Serial probe S14	1	-4	3	-	S	YES	1
/Fb	Assign defrost temperature probe (S1) - see /FA	2	-4	3	-	S	YES	2
/Fc	Assign defrost temperature probe (S2) - see /FA	3	-4	3	-	S	YES	0
/FF	Assign auxiliary temperature probe 2 (S2d2) - see /FA	0	-4	3	-	S	NO	
/FH	Assign auxiliary temperature/pressure probe 1 (Saux1) - see /FA	0	-4	3	-	S	NO	
/FI	Assign auxiliary temperature/pressure probe 2 (Saux2) - see /FA	0	-4	3	-	S	NO	
/FL	Assign ambient humidity probe (SA) - see /FA	0	-4	3	-	S	NO	
/FM	Assign ambient humidity probe (SU) - see /FA	0	-4	3	-	S	NO	
/FN	Assign dewpoint value (SP) - see /FA	0	-4	3	-	S	NO	
/GA	Outlet temperature probe (Sm) calibration	0	-20	20	°C/F	S	NO	
/GB	Defrost temperature probe (Sd) calibration	0	-20	20	°C/F	S	NO	
/GC	Intake temperature probe (S2) calibration	0	-20	20	°C/F	S	NO	
/GD	Defrost temperature probe 2 (S2d2) calibration	0	-20	20	°C/F	S	NO	
/GE	Auxiliary temperature probe 1 (Saux1) calibration	0	-20	20	°C/F	S	NO	
/GF	Auxiliary temperature probe 2 (Saux2) calibration	0	-20	20	°C/F	S	NO	
/GH	Ambient humidity probe (SA) calibration	0	-20	20	°C/F	S	NO	
/GI	Ambient humidity probe (SU) calibration	0	-20	20	°C/F	S	NO	
/GL	Dewpoint value (SP) calibration	0	-20	20	°C/F	S	NO	
/GM	Glass temperature probe (Sv) calibration	0	-20	20	°C/F	S	NO	
/GN	Condenser temperature probe calibration	0	-20	20	°C/F	M	NO	
/GO	Condenser temperature measurement stability	9	1	15	-	M	NO	

Control	Description	Def	Min	Max	UOM	User Terminal	JNRBHS	JNRZSHA
<b>Control</b>								
ON	ON/OFF command 0 = OFF, 1 = ON	0	0	1	-	S	YES	
/A	Virtual probe composition 0 = Air off probe S1h 100 = Air on probe S1	0	0	100	%	S	NO	
/Z	Minimum set point	-50	-50	72	°C/F	M	NO	25
/Z1	Maximum set point	50	71	200	°C/F	M	NO	80
/Z2	Automatic night set point variation	0	-50	50	°C/F	S	NO	80
r6	0 = Air off probe S1 01 = Inlet probe S1 02 = Inlet probe S2	0	0	1	-	S	NO	
r0	Master sensor valve configuration	0	0	20	°C/F	S	NO	
r7	0 = local valve, 1 = network valve (connected to Main)	0	0	1	-	S	YES	
S1	Set point	50	r1	r2	°C/F	U	YES	30
S2	Make probe set point with double thermostat	50	r1	r2	°C/F	S	NO	
r0	Differential	2	0.1	99.9	°C/F	U	YES	6
rC	Operating mode 0 = Direct, 1 = Reverse	0	0	1	-	U	NO	
rD2	Set point S2 differential with double thermostat 0.0 = function disabled	0	0	99.9	°C/F	S	NO	
rHS	Virtual probe composition for glass temp. probe estimate	20	0	100	%	S	NO	
rHA	0 = Air off probe S1h 100 = Air on probe S1	2	-20	20	°C/F	S	NO	
rHB	Coeff. A for glass temp. probe estimate	22	0	100	-	S	NO	
rHB	Coeff. B for glass temp. probe estimate	2	-20	20	°C/F	S	NO	
rHB	Offset for anti-sweat modulation	0	0	20	°C/F	S	NO	
rHu	Manual anti-sweat heater activation percentage (of period TH1)	70	0	100	%	S	NO	
rH	Manual anti-sweat heater activation period	5	0	180	min	S	NO	
rH	0 = function disabled	0	0	999	min	U	NO	
CLT	Max time for Clean status	0	0	240	min	S	NO	
HL1	Time light stays on after closing the door	0	0	240	min	U	NO	
dBS	Safety timeout for double thermostat function	0	0	240	min	M	NO	
db1	Double thermostat function logic 0 = AND logic, 1 = OR logic	0	0	1	-	M	NO	

Code	Description	Def	Min	Max	UOM	User Terminal	JNRBHS	JNRZSHA
<b>Digital outputs</b>								
DOA	Assign solenoid/compressor digital output 0 = not configured 1 = digital input 1 (DI1) 2 = digital output 2 (DO2) 3 = digital input 3 (DI3) 4 = digital input 4 (DI4)	2	0	4	-	S	NO	3
DOB	Assign alarm digital output - see DOA	0	0	4	-	S	NO	
DOC	Assign auxiliary digital output - see DOA	0	0	4	-	S	NO	
DOd	Assign digital output serving the Main on the Secondary device - see DOA	0	0	4	-	S	NO	
DOE	Assign light digital output - see DOA	4	0	4	-	S	NO	4
DOF	Assign defrost digital output - see DOA	0	0	4	-	S	NO	
DOG	Assign defrost digital output - see DOA	1	0	4	-	S	NO	0
DOH	Assign auxiliary evaporator defrost digital output - see DOA	0	0	4	-	S	NO	
DOI	Assign second ON/OFF compressor digital output - see DOA	0	0	4	-	S	NO	
DOJ	Assign evaporator fan digital output - see DOA	3	0	4	-	M	NO	0
DOk	Assign digital output for liquid valve (pump down)	0	0	4	-	S	NO	
DOl	Assign digital output - see DOA	0	0	4	-	M	NO	0
DOm	Assign drain heater digital output - see DOA	0	0	4	-	M	NO	0
DOp	Assign anti-sweat heater digital output - see DOA	0	0	4	-	S	NO	
DOq	Assign not gas defrost digital output - see DOA	0	0	4	-	M	NO	
DOr	Assign digital output for max fan speed connection	0	0	4	-	M	NO	
DOs	Assign digital output for min fan speed connection	0	0	4	-	M	NO	
DOt	Assign digital output for fan speed connection	0	0	4	-	M	NO	
DOu	Assign digital output for fan speed connection	0	0	4	-	M	NO	
DOv	Assign digital output for fan speed connection	0	0	4	-	M	NO	
DOw	Assign digital output for fan speed connection	0	0	4	-	M	NO	
DOx	Assign digital output for fan speed connection	0	0	4	-	M	NO	
DOy	Assign digital output for fan speed connection	0	0	4	-	M	NO	
DOz	Assign digital output for fan speed connection	0	0	4	-	M	NO	
DO1	Auxiliary digital output logic - see /OA	0	0	1	-	M	NO	
DO2	Auxiliary digital output logic - see /OA	0	0	1	-	M	NO	
DO3	Auxiliary digital output logic - see /OA	0	0	1	-	M	NO	
DO4	Auxiliary digital output logic - see /OA	0	0	1	-	M	NO	
DO5	Auxiliary digital output logic - see /OA	0	0	1	-	M	NO	
DO6	Auxiliary digital output logic - see /OA	0	0	1	-	M	NO	
DO7	Auxiliary digital output logic - see /OA	0	0	1	-	M	NO	
DO8	Auxiliary digital output logic - see /OA	0	0	1	-	M	NO	
DO9	Auxiliary digital output logic - see /OA	0	0	1	-	M	NO	
DO10	Auxiliary digital output logic - see /OA	0	0	1	-	M	NO	
DO11	Auxiliary digital output logic - see /OA	0	0	1	-	M	NO	
DO12	Auxiliary digital output logic - see /OA	0	0	1	-	M	NO	
DO13	Auxiliary digital output logic - see /OA	0	0	1	-	M	NO	
DO14	Auxiliary digital output logic - see /OA	0	0	1	-	M	NO	
DO15	Auxiliary digital output logic - see /OA	0	0	1	-	M	NO	
DO16	Auxiliary digital output logic - see /OA	0	0	1	-	M	NO	
DO17	Auxiliary digital output logic - see /OA	0	0	1	-	M	NO	
DO18	Auxiliary digital output logic - see /OA	0	0	1	-	M	NO	
DO19	Auxiliary digital output logic - see /OA	0	0	1	-	M	NO	
DO20	Auxiliary digital output logic - see /OA	0	0	1	-	M	NO	
DO21	Auxiliary digital output logic - see /OA	0	0	1	-	M	NO	
DO22	Auxiliary digital output logic - see /OA	0	0	1	-	M	NO	
DO23	Auxiliary digital output logic - see /OA	0	0	1	-	M	NO	
DO24	Auxiliary digital output logic - see /OA	0	0	1	-	M	NO	
DO25	Auxiliary digital output logic - see /OA	0	0	1	-	M	NO	
DO26	Auxiliary digital output logic - see /OA	0	0	1	-	M	NO	
DO27	Auxiliary digital output logic - see /OA	0	0	1	-	M	NO	
DO28	Auxiliary digital output logic - see /OA	0	0	1	-	M	NO	
DO29	Auxiliary digital output logic - see /OA	0	0	1	-	M	NO	
DO30	Auxiliary digital output logic - see /OA	0	0	1	-	M	NO	
DO31	Auxiliary digital output logic - see /OA	0	0	1	-	M	NO	
DO32	Auxiliary digital output logic - see /OA	0	0	1	-	M	NO	
DO33	Auxiliary digital output logic - see /OA	0	0	1	-	M	NO	
DO34	Auxiliary digital output logic - see /OA	0	0	1	-	M	NO	
DO35	Auxiliary digital output logic - see /OA	0	0	1	-	M	NO	
DO36	Auxiliary digital output logic - see /OA	0	0	1	-	M	NO	
DO37	Auxiliary digital output logic - see /OA	0	0	1	-	M	NO	
DO38	Auxiliary digital output logic - see /OA	0	0	1	-	M	NO	
DO39	Auxiliary digital output logic - see /OA	0	0	1	-	M	NO	
DO40	Auxiliary digital output logic - see /OA	0	0	1	-	M	NO	
DO41	Auxiliary digital output logic - see /OA	0	0	1	-	M	NO	
DO42	Auxiliary digital output logic - see /OA	0	0	1	-	M	NO	
DO43	Auxiliary digital output logic - see /OA	0	0	1	-	M	NO	
DO44	Auxiliary digital output logic - see /OA	0	0	1	-	M	NO	
DO45	Auxiliary digital output logic - see /OA	0	0	1	-	M	NO	
DO46	Auxiliary digital output logic - see /OA	0	0	1	-	M	NO	
DO47	Auxiliary digital output logic - see /OA	0	0	1	-	M	NO	
DO48	Auxiliary digital output logic - see /OA	0	0	1	-	M	NO	
DO49	Auxiliary digital output logic - see /OA	0	0	1	-	M	NO	
DO50	Auxiliary digital output logic - see /OA	0	0	1	-	M	NO	
DO51	Auxiliary digital output logic - see /OA	0	0	1	-	M	NO	
DO52	Auxiliary digital output logic - see /OA	0	0	1	-	M	NO	
DO53	Auxiliary digital output logic - see /OA	0	0	1	-	M	NO	
DO54	Auxiliary digital output logic - see /OA	0	0	1	-	M	NO	
DO55	Auxiliary digital output logic - see /OA	0	0	1	-	M	NO	
DO56	Auxiliary digital output logic - see /OA	0	0	1	-	M	NO	
DO57	Auxiliary digital output logic - see /OA	0	0	1	-	M	NO	
DO58	Auxiliary digital output logic - see /OA	0	0	1	-	M	NO	
DO59	Auxiliary digital output logic - see /OA	0	0	1	-	M	NO	
DO60	Auxiliary digital output logic - see /OA	0	0	1	-	M	NO	
DO61	Auxiliary digital output logic - see /OA	0	0	1	-	M	NO	
DO62	Auxiliary digital output logic - see /OA	0	0	1	-	M	NO	
DO63	Auxiliary digital output logic - see /OA	0	0	1	-	M	NO	
DO64	Auxiliary digital output logic - see /OA	0	0	1	-	M	NO	
DO65	Auxiliary digital output logic - see /OA	0	0	1	-	M	NO	
DO66	Auxiliary digital output logic - see /OA	0	0	1	-	M	NO	
DO67	Auxiliary digital output logic - see /OA	0	0	1	-	M	NO	
DO68	Auxiliary digital output logic - see /OA	0	0	1	-	M	NO	
DO69	Auxiliary digital output logic - see /OA	0	0	1	-	M	NO	
DO70	Auxiliary digital output logic - see /OA	0	0	1	-	M	NO	
DO71	Auxiliary digital output logic - see /OA	0	0	1	-	M	NO	
DO72	Auxiliary digital output logic - see /OA	0	0	1	-	M	NO	
DO73	Auxiliary digital output logic - see /OA	0	0	1	-	M	NO	
DO74	Auxiliary digital output logic - see /OA	0	0	1	-	M	NO	
DO75	Auxiliary digital output logic - see /OA	0	0	1	-	M	NO	
DO76	Auxiliary digital output logic - see /OA	0	0	1	-	M	NO	
DO77	Auxiliary digital output logic - see /OA	0	0	1	-	M	NO	
DO78	Auxiliary digital output logic - see /OA	0	0	1	-	M	NO	
DO79	Auxiliary digital output logic - see /OA	0	0	1	-	M	NO	
DO80	Auxiliary digital output logic - see /OA	0	0	1	-	M		

# D10: CONTROLLERS AND SETPOINTS

Code	Description	Def	Min	Max	UOM	User Terminal	JNRBHSA	JNRZSHA
<b>Defrost</b>								
d0	Type of defrost 0 = heater by temperature 1 = hot gas by temperature 2 = heater by time 3 = hot gas by time 4 = temperature control with heater by time	0	0	4	-	S	YES	0 1
dEP	Assign probe for end defrost in advance 0 = Not configured 1 = Outlet (Sn) 2 = Defrost (Sd) 3 = Intake (Si) 4 = Defrost 2 (Sd2) 5 = Auxiliary 1 (Saux1) 6 = Auxiliary 2 (Saux2) 7 = Ambient humidity (SU) 8 = Ambient humidity (SV) 9 = Glass temperature (Sv) 10 = Dew point (SDP) 11 = Virtual probe (Sv)	0	0	11	-	S	NO	
dET	Temperature threshold for end defrost in advance	50	99.9	99.9	°C	S	NO	
d2	End defrost synchronized by Main 0 = not synchronized, 1 = synchronized	1	0	1	-	S	NO	
d3	Send start network defrost signal (for Main) Ignore start network defrost signal (for Secondary) 0 = no, 1 = yes	0	0	1	-	S	NO	
d4	Maximum interval between consecutive defrosts	8	0	240	hours	S	YES	12 24
d5	End defrost temperature (read by Sd)	8	-50	50	°C/F	S	YES	40 72
dP1	Maximum defrost duration	45	1	240	min	S	YES	46 30
dP2	Max secondary evaporator defrost duration	45	1	240	min	S	NO	
d4	Defrost on power on (Main = network defrost; Secondary = local defrost) 0 = No, 1 = Yes	0	0	1	-	S	NO	
d5	Defrost delay at power-on or (for Secondary) after control signal from Main 0 = delay disabled	0	0	240	min	S	NO	
d6	Display on terminals during defrost 0 = temperature alternating with °F 1 = freeze display 2 = °C/F	1	0	2	-	U	NO	0 0
dD	Dripping time after defrost (fans off) 0 = no dripping	2	0	15	min	S	NO	0 0
d7	Skip defrost 0 = disabled, 1 = enabled	0	0	1	-	S	NO	
d8	Bypass high temperature alarm time after defrost	30	1	240	min	S	NO	
d9	Defrost priority over compressor protection times 0 = compressor protection times observed, 1 = compressor protection times ignored	1	0	1	-	M	NO	
d10	Defrost time in Running time mode 0 = function disabled	0	0	240	min	S	NO	
d11	Defrost temperature threshold in Running time mode 0 = pump down disabled 1 = function disabled	-30	-50	50	°C/F	S	NO	
dS1	Compressor off time in sequential stop defrost mode 0 = function disabled	0	0	999	s	M	NO	
dS2	Compressor operating time in power defrost mode	120	0	240	min	M	NO	
dD1	Additional end defrost temperature delta in power defrost mode 0 = function disabled	0	-20	20	°C/F	S	NO	
dD	Additional maximum defrost time delta in power defrost mode	75	0	60	min	S	NO	
r3	Nominal defrost duration for skip defrost End defrost by timeout signal 0 = disabled, 1 = enabled	0	0	1	-	S	NO	
c7	Defrost priority over continuous cycle 0 = No, 1 = Yes	0	0	1	-	M	NO	
dd1	Assign probe 1 to determine start defrost (d41-d42) - see FSa	0	0	14	-	S	NO	
dd2	Assign probe 2 to determine start defrost (d41-d42) - see FSa	0	0	14	-	S	NO	
dTd	Temperature differential threshold to start defrost	50	99.9	99.9	°C	S	NO	
td	Threshold evaluation time to start defrost	60	15	240	min	S	NO	
cdF	Compressor frequency during hot gas defrost procedure	140	0	255	Hz	S	NO	
cdF	Compressor frequency during dripping phase after hot gas defrost	140	0	255	Hz	S	NO	
dHG	Hot gas activation delay	0	0	300	s	S	NO	

Code	Description	Def	Min	Max	UOM	User Terminal	JNRBHSA	JNRZSHA
<b>Defrost scheduling</b>								
tdf1.8-d	Defrost 1 to 8 - day 0 = event disabled 1 to 7 = Monday to Sunday 8 = Monday to Friday 9 = from Monday to Saturday 10 = Saturday & Sunday 11 = every day	0	0	11	day	S	NO	0 11
tdf1.8-h	Defrost 1 to 8 - hours	0	0	23	hours	S	NO	0 3
tdf1.8-mm	Defrost 1 to 8 - minutes	0	0	59	minutes	S	NO	
tdf1.8-P	Defrost 1 to 8 - enable power defrost. 0 = normal, 1 = power defrost	0	0	1	-	S	NO	
dFS	Number of daily defrosts (dF1) 0 = Disabled 1 = 24 hours and 0 Minutes 2 = 12 hours and 0 Minutes 3 = 8 hours and 0 Minutes 4 = 6 hours and 0 Minutes 5 = 4 hours and 0 Minutes 6 = 4 hours and 26 Minutes 7 = 3 hours and 26 Minutes	0	0	14	-	S	NO	
d2S	Number of daily defrosts (d2) - see d1S	0	0	14	-	S	NO	
<b>Evaporator fans</b>								
F0	Evaporator fan management 0 = always on 1 = activation based on Sa - Sb (see FSa and FSb) 2 = activation based on Sa (Sa = first probe, Sb = second probe)	0	0	2	-	S	YES	0 2
F1	Evaporator fan activation threshold (only if F0 = 1 or 2)	-5	-50	50	°C/F	S	YES	30 40
F2	0 = see F0 1 = always off	1	0	1	-	S	YES	0 0
F3	Evaporator fans during defrost 0 = On, 1 = On time after defrost (fans off with control active)	1	0	1	-	S	F3	0 1
F4	Fan setpoint differential (including variable speed)	2	0	15	mph	S	NO	
F5	Evaporator fan cut-on temperature (hysteresis 1 °C)	2	0	20	°C/F	S	YES	
F6	Maximum evaporator fan speed	100	F1	50	°C/F	S	NO	
F7	Minimum evaporator fan speed	0	0	100	%	M	NO	
F8	Evaporator fan peak time 0 = evaporator fan speed 1 = Fan speed	0	0	P6	%	M	NO	
F10	Evaporator fan forcing time at maximum speed 0 = Function disabled	0	0	240	min	M	NO	
FSa	First fan control probe 0 = Not configured 1 = Outlet (Sm) 2 = Defrost (Sd) 3 = Intake (Si) 4 = Inlet (Sv) 5 = Auxiliary 1 (Saux1) 6 = Auxiliary 2 (Saux2) 7 = Ambient humidity (SU) 8 = Ambient humidity (SV) 9 = Glass temperature (Sv) 10 = Dew point (SDP) 11 = Virtual probe (Sv)	2	0	11	-	M	NO	
FSb	Second fan control probe - see FSa 0 = On, 1 = Off	11	0	11	-	M	NO	
Fpd	Evaporator fans during post-dripping	0	0	1	-	0	NO	
POM	Unit cooling capacity indication	4000	0	32000	watts	M	NO	

REV	DATE	ECN	NO	DESCRIPTION
01	1/16/25	123680	X	RELEASED TO PRODUCTION

UNITS	INCHES - (MM)
LOCATIONS	(0) UNLESS SPECIFIED
ALL ANGULAR DIM.	(1) UNLESS SPECIFIED
DIMENSIONS ON FORMS	UNLESS OTHERWISE SPECIFIED
DRAWINGS NOT TO SCALE	

Display Cases	DATE	BY	DATE
01	01/16/25	AWM	01/16/25

SETPOINTS: MPX0, 2-5DR LT & MT, R290, BETA CASE, STD WITH MOTION SENSOR

R908293

SHEET 2 OF 4





# D13: CONTROLLERS AND SETPOINTS

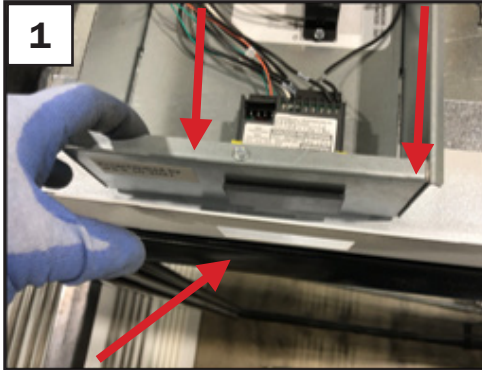
Setpoints for MPXzero Advanced - SOMPSA4B03S0274 (P118072H)				
NAME	ACRONYM	Value LT 2-5 DR	Value MT 2-5 DR	Value MT 1DR
Temp Unit	/5	1	1	1
Decimal pt	/6	1	1	1
Control Diff	rd	4	6	6
Minimum SetP	r1	-25	25	25
Maximum SetP	r2	80	80	80
Temp Setpoint	St	-5	30	36
Comp On Time	c2	5	5	5
Comp Off Time	c3	5	5	5
Defrost Interval	dl	24	12	12
Defrost Term Temp	dt1	48	40	40
Max Defrost Time	dP1	46	46	46
Drip Time	dd	0	0	0
Alarm Type	A1	0	0	0
High Temp Alarm	AH	69	30	30
Low Temp Alarm	AL	6	6	6
Fan Management	F0	2	0	0
Fan Start Temp	F1	30	30	30
Fans with comp	F2	0	0	0
Fan cycle defrost	F3	1	0	0
Defrost Day	td1-d	11	0	0
Defrost Hour	td1-hh	3	0	0
Defrost Display	d6	0	0	0
Discharge Air	/FA	1	1	1
Defrost Termination	/Fb	2	2	2
Return Air	/Fc	0	0	0
Drain Heater	DOP	4	0	0
Defrost Heaters	DOG	1	0	0
Fans	DOI	2	0	0
Compressor	DOA	3	3	3
Lights	DOE	0	0	0
Main/Secondary type	In	1	1	1
Defrost Trigger DI	DId	1	1	1
Relay Type	DOT1	3	3	3
	DOT2	3	3	3
	DOT3	3	3	3
	DOT4	3	3	3
				P118567K

# E1: FASCIA FRAME

## NOTES:

- Both sides of the fascia frame are called the “End Fascia”, as the frame is symetrical and either end can be right or left.
- Holes on top of the front panels are for paint line, no field screws needed (see last picture in instructions for example).

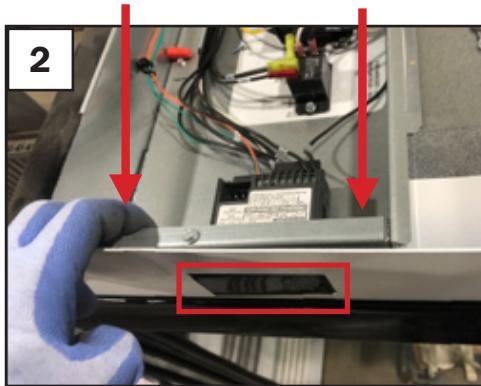
Push Base (white metal frame) into black frame-flange so it sits tight against it.



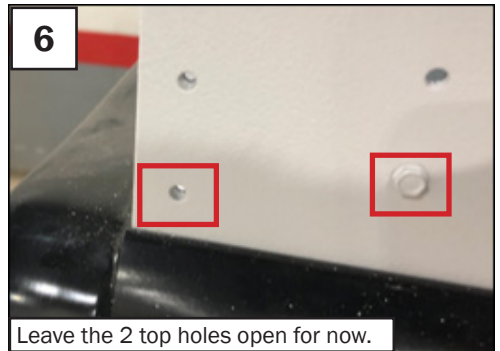
Fasten the top of the bigger, end fascia to the smaller end fascia.



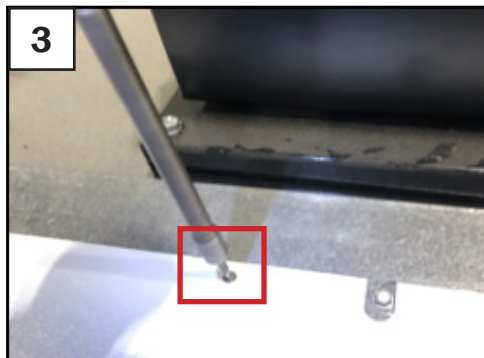
Slide gray controller box against white painted cut-out on top of the case so the controller face shows through cut-out.



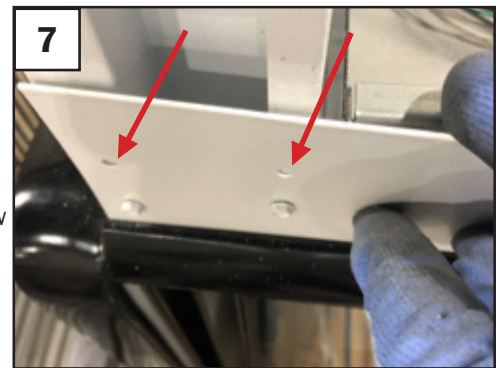
Fasten the end fascia at the bottom two holes ONLY.



Fasten fascia base to the case at the punched out holes only.



Keep top two screw holes of base loose for now until step 14



Nest the smaller, adjustable end fascia inside the larger end fascia.



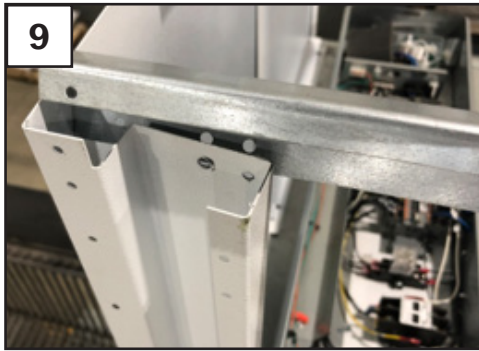
Fasten the end fascia you are currently working on, to case.

Repeat steps 4-8 for the other end fascia side.



## E2: FASCIA FRAME

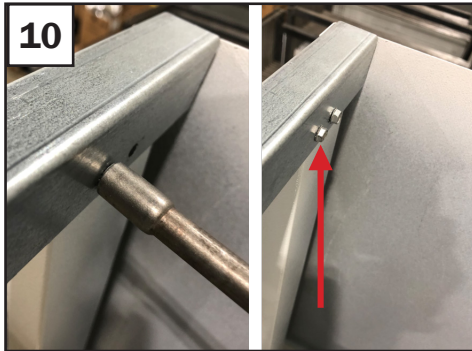
PLACE the top metal frame bar across one end fascia to the other. Do not fasten the metal bar to the frame at this point.



Slide panels behind fascia base.



Fasten from REAR (pre-punched)



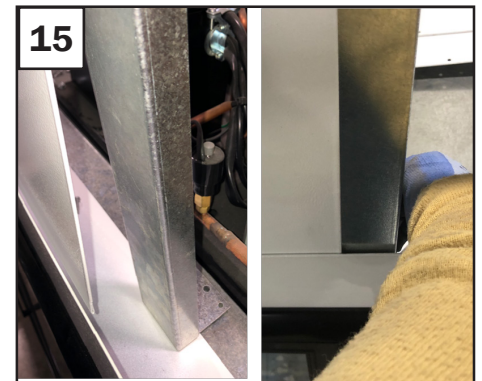
Fasten top front screws (base) to secure panels.



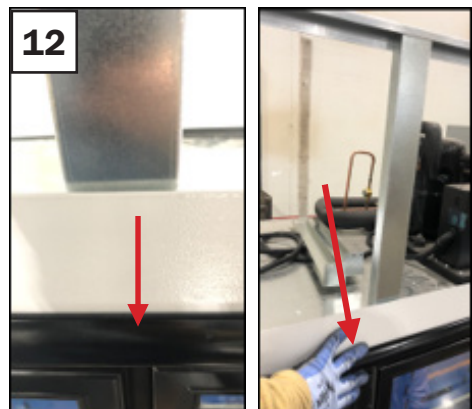
Slide vertical trim piece into the bottom of the top frame bar.



Slide trim tight against panels that were just installed in step 13.



Align vertical trim piece to the center frame mullions below.



Fasten the panels and the vertical trim pieces using the pre-punched holes only

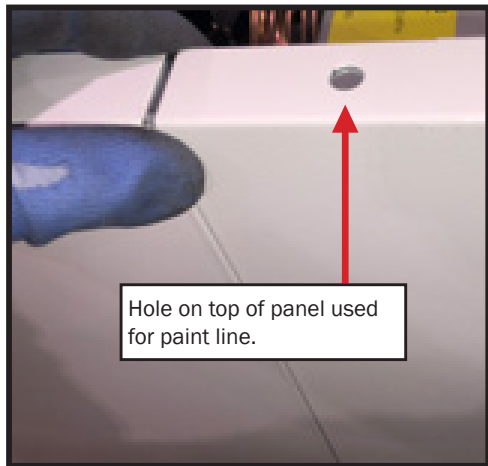


## E3: FASCIA FRAME

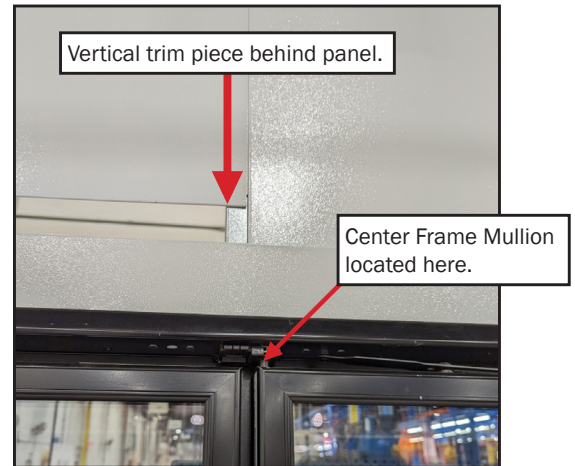
View of final set up with fascia installed on top of case.



### **EXAMPLES:**



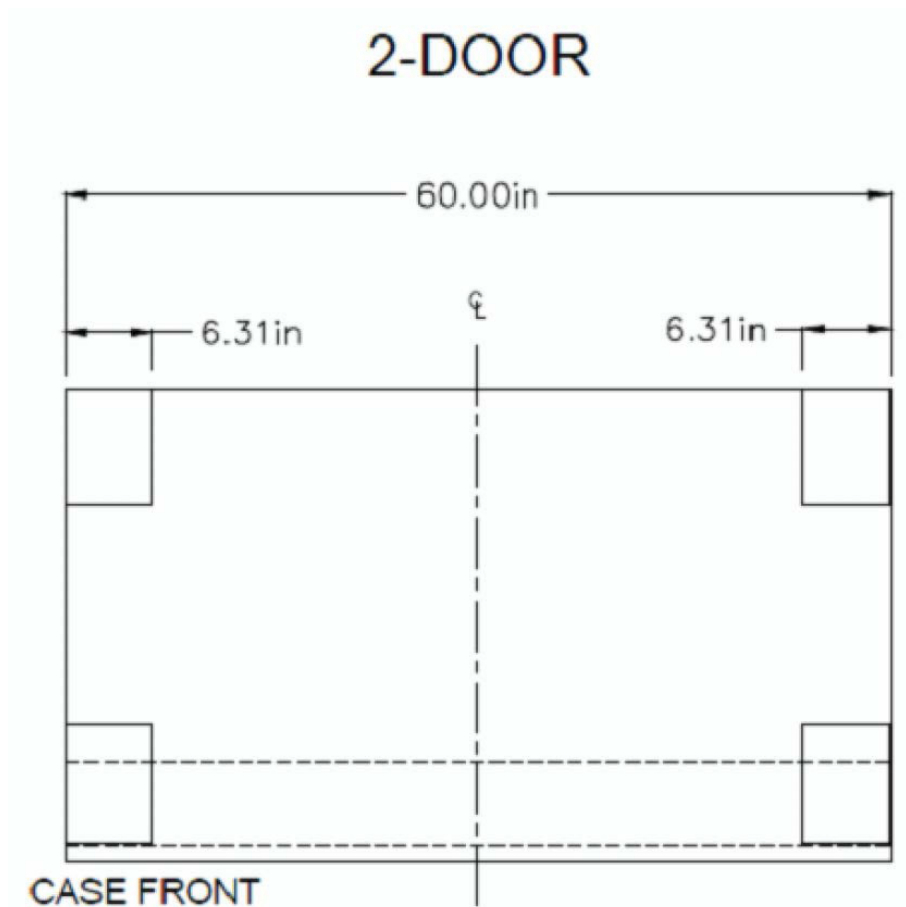
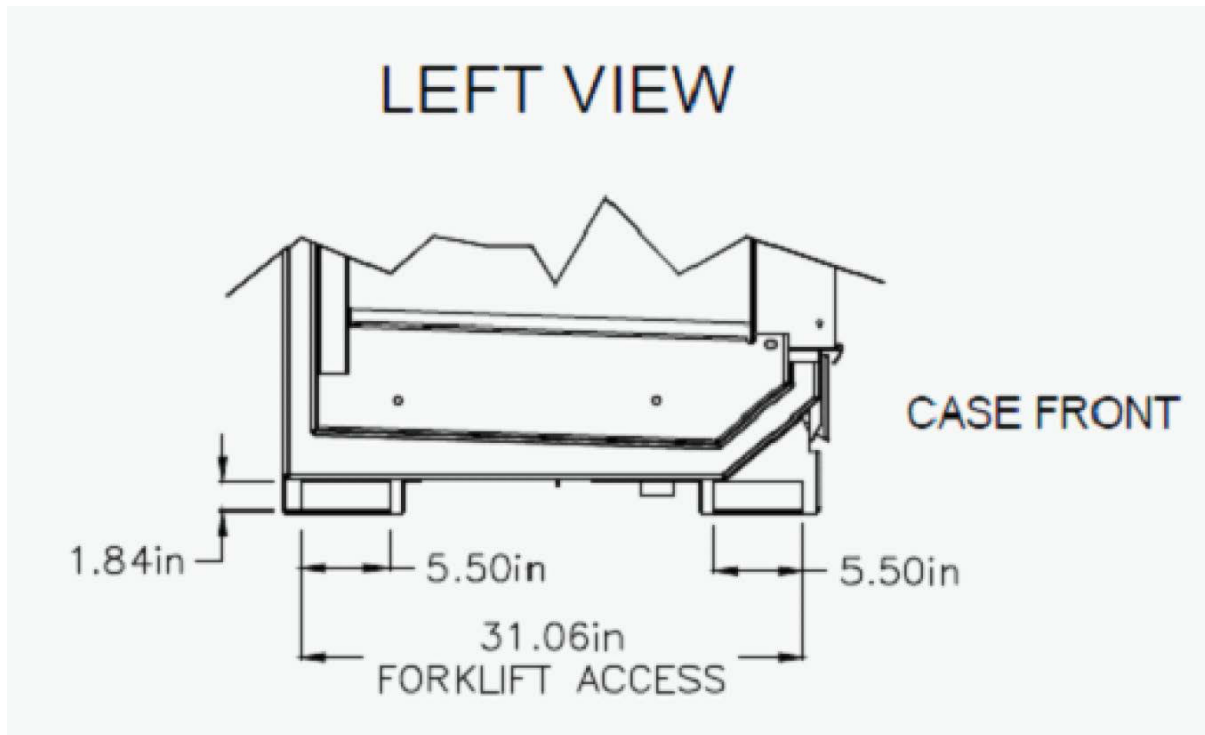
**NOTE:** This is an example of a hole on top of the fascia that is not to be used as a screw hole. There are several of these on the fascia panels and are used by Hillphoenix for painting purposes.



**NOTE:** The vertical trim pieces are required above every center frame mullion.

# F1: CASE LIFTING LOCATIONS

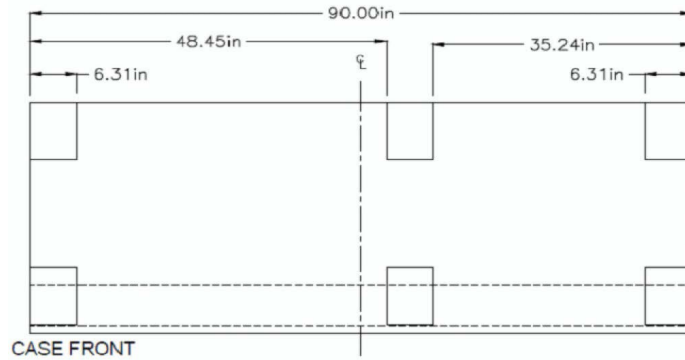
## Base Frame Lifting Locations for Forklift – JNRBHSA/JNRZHSA



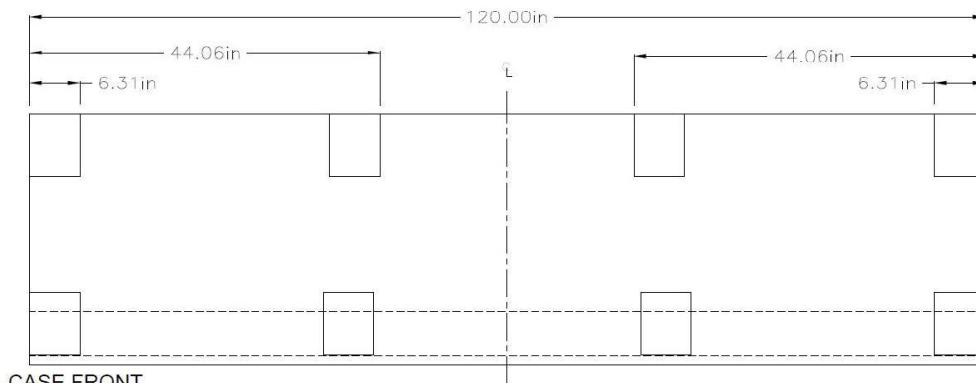
## F2: CASE LIFTING LOCATIONS

### Base Frame Lifting Locations for Forklift – JNRBHSA/JNRZHSA

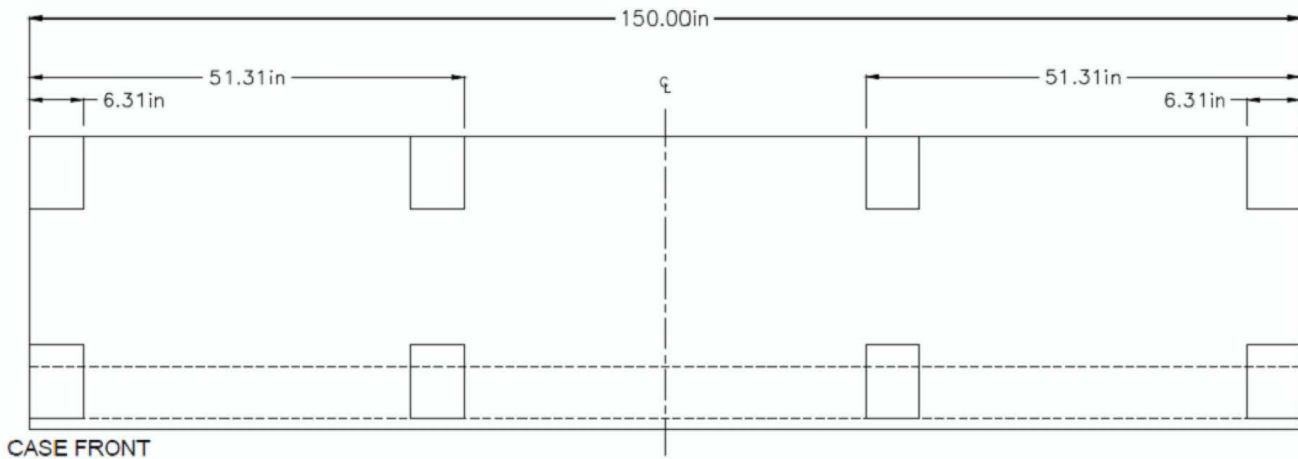
#### 3-DOOR



#### 4-DOOR



#### 5-DOOR



# ADDENDUM: SEQUENCE OF OPERATIONS - R-290 CASE START-UP

## Pre-checks

1. Before providing power to the Case, confirm that the building's power is in lockout / tagout.
2. Confirm that the circuit breaker installed on the Case is in the OFF position.
3. Verify the power from the building is correct for the case, in both the number of phases and voltage.
4. Make the necessary input power connections on the Case junction box field terminal blocks and circuit breaker.
5. Confirm that the field power terminal block wiring is landed per the Case wiring diagram.
6. Confirm that there are no objects in the Case from field install and all covers are installed.
7. When ready to start up the Case, confirm the building power lockout / tagout is removed.
8. Confirm that the connections of the case harnesses are secure and fully snapped into their mating connectors. Also, check the female connectors for debris prior to making the connections.

## Start-Up

1. To power the case, switch the Case circuit breaker to the ON position.
  2. The MPXzero controller will begin its boot-up process, and after roughly 1 minute, the compressor will start up, and the condensing unit fans will begin running.
  3. The Case will be in a defrost cycle upon its FIRST power up. If the controller is powered OFF and then back ON, the Case will be in regulation.
    - A. If the Case is in a defrost cycle, the evaporator fans will be OFF in a Low-Temp Door Case only if the coil suction line temperature is above 40°F. For all other Case types, the evaporator fans will be ON regardless of the suction line temperature.
  4. If a motion sensor is installed on the Case, the lights will not come on until activity is sensed in front of the Case.
- \*See table 1 on the last Addendum page for the Quick Reference of the Expected Operation for Each Component.
5. If the Case starts in a defrost cycle, the controller will switch to refrigeration mode once the defrost termination temperature is reached.



- A. For Low-Temp Door Cases, the defrost termination temperature is 72°F on the suction line.
  - B. For Low Temp Door Cases, the fans will remain OFF until the suction line temperature reached 40°F during pulldown.
6. Check the MPXzero display for the status of the Case.

- A. If in defrost, the defrost icon will be illuminated and the fans icon may or may not be illuminated depending on the Case type.



- B. If in refrigeration mode, the compressor icon will be illuminated and there should be no alarms present.
7. While the Case is in refrigeration mode, check that case is pulling down to temperature by observing the value of the discharge air displayed on the controller. The value should be steadily dropping.



8. During pulldown, the compressor will run continuously until the Case temperature setpoint is reached.
9. When the Case temperature setpoint is reached, the compressor will cycle ON and OFF per the cut-in/cut-out settings.
  - A. Note that there is a minimum runtime for compressor, which is set to 5 min.
10. The evaporator fans will run continuously while in refrigeration mode (and when below 40°F for LT door Cases) .
11. For Cases that are less than 150g, the condensing unit fans will cycle ON/OFF with compressor. For Cases that are greater than 150g, the condensing unit fans will be ON continuously.
12. Keep monitoring the display to ensure that the Case temperature remains at the temperature setpoint +/- the cut-in/cut-out settings.

## Troubleshooting

1. Issue – The compressor will not turn on or will turn on briefly and turn off by low pressure (LP switch).
  - A. Probable gas leak exists.
    - i. Put a pressure gauge on the Schrader port to read the actual pressure – if it is less than 4 psi then there is probably a gas leak.
    - ii. Find the leak, fix the leak, and recharge the Case (see separate instructions on the charging process).
      - a. All charging to be done by a licensed service professional.
2. Issue – Case is not pulling down while in refrigeration mode
  - A. Solenoid valves may be the incorrect type.

## ADDENDUM: SEQUENCE OF OPERATIONS - R-290 CASE START-UP

- i. Make sure that the solenoid positioned in between the compressor to condenser is Normally Open. Make sure that the two remaining solenoids are Normally Closed.
- B. Check valve may be installed backwards.
  - i. Confirm the valve is installed in the correct orientation.
3. Issue - Case is taking too long to pull down.
  - A. The wrong TXV may be installed.
  - B. The wrong orifice may be installed on the distributor.
4. Issue - Incorrect temperature reading or rE / E1 / E2 errors on the display.



- A. Probes may be wired incorrectly or terminated insufficiently.
- B. The wrong type of probe may be installed.
5. Issue - Case component is not turning on when intended.
  - A. Use Applica to check the following:
    - i. There are no duplicate assignment (1-4) to output parameters DOA, DOG, DOE, DOI, DOP.
      - a. DOA - CDU
      - b. DOG - Defrost
      - c. DOE - Lights
      - d. DOI - Fans
      - e. DOP - Drain Heater
    - ii. Fans output polarity parameter rol is set correctly.
      - a. rol = 1 - for R-290
      - b. rol = 0 - for HFC
    - iii. The controller relay outputs NO1-NO4 are functional.
      - a. Using a multimeter, check the voltage on the relay outputs. If the reading of the multimeter is ~120VAC, then the relay is CLOSED. If the reading is ~0V, then the relay is OPEN. Use this to confirm that the relay will open/close when expected.
6. Issue - The compressor is not running when expected.
  - A. Check that there are no problems with the discharge air probe, per Issue # 4 above.
  - B. Check that there are no problems with the controller programming or relays, per Issue # 5 above.
  - C. Check that the high and low pressure switches are both CLOSED.
    - i. Using a multimeter, check the voltage at the output wiring of the pressure switches. If the reading is 120VAC, then the switches are CLOSED. If the reading is 0V, then one of the switches is OPEN and thus keeping the compressor from running.
7. Case turns on and after compressor start, Case shuts down.
  - A. Using a DMM check for proper incoming voltage on each phase of supply to Case. If one or more phases show low or zero voltage check the following:
    - i. Check panel breaker to see if it is tripped. If tripped check to see that breaker is sufficient for Case load based on MOP on Case data tag. If not, contact electrical contractor.
    - ii. If panel breaker is sufficient for Case load, discuss with the electrical contractor to see what other loads are on the circuit. If circuit is overloaded, then second supply will be needed.
  - B. If building supply is correct, compare Case wiring to supplied wiring diagram and correct any issues.
  - C. If no wiring issues are found, disconnect wires to compressor and start Case. If panel breaker does not trip and other Case loads function correctly, the compressor may be defective.
8. Case runs but light(s) do not come on.
  - A. If Case has separate building power feed for lights, make sure it is connected and there is power from the feed to the Case.
  - B. Check that lights are wired correctly by comparing to wiring diagram.
  - C. If lights are wired to controller and controller has N.O. and N.C. contacts for lights, check that lights are on the correct set of contacts. If wired correctly, check if program is correct in controller.
  - D. Remove the wires from the controller connection at the controller and connect together. If lights come on, the controller maybe defective.
  - E. If Case has motion sensor for lights, check that it is wired correctly and provide motion in front of sensor. If lights do not turn on, disconnect the wires from the motion sensor and connect together. If lights turn on, motion sensor might be defective.
  - F. Apply power directly to the input of the LED driver. If lights do not come on, check for 24VDC at the output of the LED driver. If output of LED driver is zero, then driver is defective. If output is 24VDC, then check wiring from driver to LEDs
9. Case runs but evaporator fans do not come on.
  - A. If fans are on separate building power feed, check that there is power to the field connection point of the fans.
  - B. If fans have building power and are wired directly to building power, then check for power at the fans. If no power at fans, verify that fan wiring is correct.
  - C. If fan wiring is correct and fans do not run, apply power directly to fan. If it does not run, fan maybe defective.
  - D. If fans are wired through controller and controller has N.O and N.C. contacts for the fans, verify that fans are wired to correct contacts.
  - E. If fans are wired to correct contacts, then check that controller program is correct.
  - F. If controller program is correct, then remove the fan wires from the controller and connect together. If fans come on, controller maybe defective.

## ADDENDUM: SEQUENCE OF OPERATIONS - R-290 CASE START-UP

**Table 1. QUICK REFERENCE OF EXPECTED OPERATION OF EACH COMPONENT**

	2-5DR Medium Temp		2 DR Low Temp		3-5DR Low Temp	
	<150g R290 Charge MT		<150g R290 Charge LT		>150g R290 Charge LT	
Component	During Normal Op	During Time-Off DEF	During Normal Op	During Hot-Gas DEF	During Normal Op	During Hot-Gas DEF
Condenser Fan	will cycle	OFF	will cycle	ON	ON	ON
Evaporator Fan	ON	ON	ON	OFF	ON	OFF
AUX Fan	N/A	N/A	N/A	N/A	N	Y
Compressor	will cycle	OFF	will cycle	ON	will cycle	ON
Cond LL Sol NO	N/A	N/A	open	closed	open	closed
Cond HG Sol NC	N/A	N/A	closed	open	closed	open
TXV bypass Sol NC	N/A	N/A	closed	open	closed	open
Lights*	ON	ON	ON	ON	ON	ON
120V Tank-assist Htr	N/A	N/A	OFF	ON	OFF	ON

## Warning Maintenance & Case Care

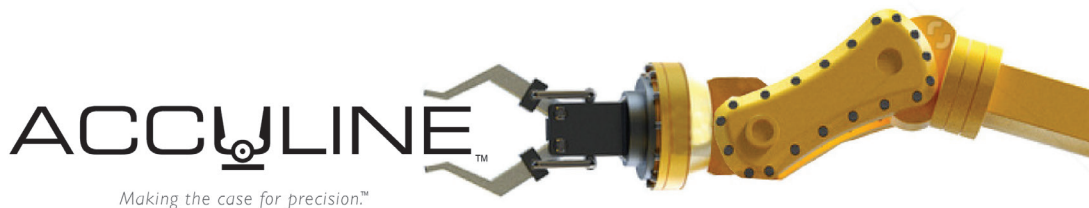
When cleaning cases the following must be performed PRIOR to cleaning:

To avoid electrical shock, be sure all electric power is turned off before cleaning. In some installations, more than one switch may have to be turned off to completely de-energize the case.

Do not spray cleaning solution or water directly on fan motors or any electrical connections.

All lighting receptacles must be dried off prior to insertion and re-energizing the lighting circuit.

Please refer to the Use and Maintenance section of this installation manual.



Tel: 1-804-614-1457

1925 Ruffin Mill Rd, Colonial Heights, VA 23834  
Due to our commitment to continuous improvement, all specifications are subject to change without notice.  
Hillphoenix is a Sustaining Member of the American Society of Quality.  
Visit our website at [www.hillphoenix.com](http://www.hillphoenix.com)



A  COMPANY

## LIMITED & GENERAL WARRANTY TERMS

Hill Phoenix, Inc's. (hereinafter "Hillphoenix") products are warranted to be free from defects in materials and workmanship under normal use and maintenance for a period of 14 months from date and place of shipment from Hillphoenix (the "Base Warranty Period"), provided that the installation and maintenance of such products have been performed strictly in accordance with Hillphoenix's designated specifications.

Anthony products supplied as original equipment on Hillphoenix products receive Hillphoenix warranty.

All warranty repairs must be approved in advance before services are started. In the event of a qualifying warranty claim, the extent of Hillphoenix's liability under the Warranty is limited to the repair or replacement, at Hillphoenix's option, of any non-conforming products without charge. If required, a new or rebuilt part to replace any defective part will be provided without charge and will be shipped via standard ground freight, with shipping charges being covered by Hillphoenix during the base warranty period. The replacement part is covered under this warranty for the remainder of the applicable Base Warranty Period. In order to be eligible for warranty coverage, customer must: (i) notify Hillphoenix in writing within twenty-four hours upon discovery of a warrant defect, and (ii) comply with the warranty claim procedures provided by Hillphoenix from time to time. These warranty terms are incorporated into and governed by the Hill Phoenix Terms and Conditions of Sale.

This equipment warranty does not include labor or other costs incurred for diagnosing, repairing, removing, installing, shipping, servicing, or handling of either defective parts or replacement parts.

The warranty shall not apply:

1. To any unit or any part thereof which has been subject to an accident, alteration, negligence, misuse or abuse, or which has not been operated in accordance with the manufacturer's recommendations, or in conditions outside of Manufacturer's specifications, or if the serial number of the unit has been altered, defaced, or removed.
2. When the unit, or any part thereof, is damaged by fire, flood, or other act of God.
3. To products that are impaired or damaged due to improper installation.
4. When installation and startup forms are not properly completed or returned within two weeks after startup.
5. If the defective part is not returned to the Manufacturer.
6. To service, maintenance or wear and tear parts (such as lights, starters and ballasts)
7. To cosmetic damage (e.g., scratches, dents, chips, and other damage to appliance finishes), unless such damage results from defects in materials and workmanship and is reported to Hillphoenix within 30 days from date of purchase.
8. To shipping damage
9. To use in a non-commercial application
10. Corrosion, discoloration, oxidation, or rust due to exposure to predisposed corrosive environments/atmospheres or contact with product damaging material/chemicals
11. To service trips where no problem is diagnosed or found in the discretion of Hillphoenix
12. To Removal/reinstallation of product for repair if installed in an inaccessible location
13. To use of non-OEM parts for warrantable repair unless directed by Hillphoenix
14. To repair/service tools/items
15. To service trips to teach customer how to use product
16. To product pick-up or delivery for repair purposes; repairs should take place on the customer's site unless directed by Hillphoenix
17. To misdiagnosis or misrepair, including subsequent labor/component repair or replacement
18. To stolen components
19. To replacement service parts lost or misplaced on arrival by receiving personnel
20. To service events on non-DFR products
21. To excess repair time
22. To excess required consumables charges, at the discretion of Hillphoenix
23. If a service contractor takes longer than 120 days from the date of repair completion to submit a warranty invoice/claim

Examples of non-warrantable situations include, but are not limited to:

- Non-factory electrical connection or component issues
- Product is operated on low or improper voltages
- Use of extension cords to power the product
- Lack of basic preventative maintenance as outlined by product manuals
- Installation into a mobile application
- Failures or symptoms that result from site mechanical or electrical failures

- Loading of food or other content that prevents the product from operating properly
- 'Yellowing' of lighting products

#### MODIFICATIONS TO GENERAL WARRANTY

The following sets forth certain modifications to the General Warranty for specific products of Manufacturer:

#### DISPLAY CASE AND SPECIALTY PRODUCTS CLEARVOYANT® LED LIGHTING

The warranty period for Clearvoyant LED lighting components within the Clearvoyant lighting system is five years from date of shipment.

#### NO WARRANTY FOR NON-STANDARD PRODUCTS

A " Non-Standard Product" is any product that is different in any manner from any Hillphoenix product that has been previously designed and manufactured by Hillphoenix in accordance with its standard specifications. A Non-Standard Product also includes any standard Hillphoenix product that has been specially designed or modified to meet a particular Buyer specification, or that contains any additional or substituted product, part, accessory, equipment, fixture, component or material, or that has been assembled, manufactured, produced, or installed by any method or process, which is different from Hillphoenix' s standard specifications for such product. Hillphoenix expressly disclaims and makes no warranties, express or implied, as to the condition, design, utility, quality, adequacy, or capacity with respect to any standard or Non-Standard Product, including, without limitation, any warranty of merchantability or fitness of such product for a particular purpose or intended use, whether or not such product has been designated by Hillphoenix as a Non-Standard Product. All Non-Standard Products, whether sold separately, or incorporated and/or attached to standard Hillphoenix products, and all services relating to such products, are sold to and accepted by Buyer " as is" and "with all faults" . Without limiting any other provision of this purchase order, Hillphoenix shall have no liability to Buyer for any claim, loss, damage, consequential damages or expenses associated with any Non-Standard Product and/or its use or operation, or any other equipment or property of Buyer caused by or alleged by to be caused by any such product or its use or operation, whether directly, indirectly, incidentally or consequentially, or by any inadequacy thereof or deficiency or defect therein. The foregoing exclusion of warranty cannot be modified or waived except as expressly set forth in a writing signed by an officer of Hillphoenix authorized to make such modification or waiver.

#### REMEDY LIMITATION/DAMAGES EXCLUSION

THE REMEDY OF REPAIR OR PROVISION OF A REPLACEMENT PART WITHOUT CHARGE SHALL BE THE EXCLUSIVE REMEDY FOR ANY WARRANTY CLAIM HEREUNDER. WITHOUT LIMITING THE FOREGOING, HILLPHOENIX SHALL NOT BE LIABLE UNDER ANY CIRCUMSTANCES FOR INCIDENTAL, INDIRECT, LIQUIDATED OR CONSEQUENTIAL DAMAGES, INCLUDING LOSS OF PROFIT, LABOR COST, LOSS OF REFRIGERANT OR FOOD PRODUCTS.

#### EXCLUSIVE WARRANTY

THE FOREGOING WARRANTY IS THE EXCLUSIVE WARRANTY WITH RESPECT TO THE PRODUCTS. ALL OTHER WARRANTIES, WHETHER EXPRESS OR IMPLIED, INCLUDING WITHOUT LIMITATION, THE WARRANTIES OF MERCHANTABILITY OR FITNESS FOR A PARTICULAR PURPOSE, ARE HEREBY DISCLAIMED AND EXCLUDED. NO IMPLIED WARRANTY SHALL BE DEEMED CREATED BY COURSE OF DEALING OR USAGE OF TRADE. NO OTHER PERSON IS AUTHORIZED TO EXPAND OR CREATE ANY OBLIGATION GREATER THAN OR MORE EXPANSIVE THAN THE WARRANTY PROVIDED HEREIN.

THE ABOVE WARRANTY IS GIVEN IN LIEU OF ALL OTHER WARRANTIES, EXPRESSED OR IMPLIED, INCLUDING ANY IMPLIED WARRANTIES OF MERCHANTABILITY OR FITNESS FOR A PARTICULAR PURPOSE. HILLPHOENIX SHALL NOT BE RESPONSIBLE FOR INCIDENTAL OR CONSEQUENTIAL DAMAGES INCLUDING BUT NOT LIMITED TO INJURY TO PERSONS OR PROPERTY. NOTWITHSTANDING ANYTHING TO THE CONTRARY, HILLPHOENIX'S ENTIRE LIABILITY, AND BUYER'S EXCLUSIVE REMEDY, IN LAW AND EQUITY OR OTHERWISE, WITH RESPECT TO ANY PRODUCTS PROVIDED BY HILLPHOENIX IS SOLELY LIMITED TO THE AMOUNT PAID BY BUYER FOR THE PRODUCTS TO WHICH THE APPLICABLE CLAIM RELATES.

THIS DOCUMENT DOES NOT GOVERN EXTENDED WARRANTIES AND ANY EXTENDED WARRANTIES PROVIDED BY HILLPHOENIX SHALL BE GOVERNED BY A SEPARATE DOCUMENT AGREED UPON BY HILLPHOENIX

Submit warranty claims to: [hpx-warranty-wa-invoices@doverfoodretail.com](mailto:hpx-warranty-wa-invoices@doverfoodretail.com)

**For warranty service, please**

**contact Hill Phoenix at:**

Phone: 1-833-280-5714