

MULTI-DECK SELF-CONTAINED MERCHANDISER INSTALLATION & OPERATIONS MANUAL

05DMA-NRG, 05MA-NRG, 0N5DMXA-NRG, & 0N5MXA-NRG (R-290)



WARNING / FOR YOUR SAFETY
Do not store or use gasoline or other flammable vapors and liquids in the vicinity of this or any other appliance.

WARNING
R-290 flammable refrigerant in use. Improper installation, adjustment, alteration, service or maintenance can cause property damage, injury or death. Read the installation, operating and maintenance instructions thoroughly before installing or servicing this equipment.

Table of Contents

General Information	1	Fans & Case Cleaning	14
Case Installation	2-5	Troubleshooting	15-16
Case Connections	6-9	Safety Devices & Service.....	17-19
Pre-Power Checklist	10	Parts Ordering	20
Lighting & Power Supplies	11-12	Appendix	21
Airflow & Defrost	13		

To ensure proper functionality and optimum performance, it is strongly recommended that Hillphoenix display cases be installed/serviced by qualified and certified technicians who have experience working with commercial refrigerated display merchandisers and storage cabinets. For a list of Hillphoenix authorized installation/service contractors, please visit our Web site: www.hillphoenix.com



a DOVER company

P120134B
V1.04
02/2026

Copyright © 2025 by Hill PHOENIX

All rights reserved. No part of this document may reproduced or transmitted in any form or by any means - i.e., electronic or mechanical, including photocopying, recording or any other information storage and retrieval system - without express written permission from Hill PHOENIX.

LIABILITY NOTICE

For Cases with Shelf Lighting Systems

Hillphoenix shelf lighting systems as well as display cases with alternative shelf lighting are not designed to withstand direct or indirect exposure to water or other liquids systems except Clearvoyant™ 4 with the proper use of dielectric grease . The use of a misting system or water hose on a display case with an unapproved shelf lighting system, resulting in the direct or indirect exposure of the lighting system to water, can lead to a number of serious issues (including, without limitation, electrical failures, fire, electric shock, and mold) in turn resulting in personal injury, death, sickness, and/or serious property damage (including, without limitation, to the display case itself, to the location where the display case is situated [e.g., store] and to any surrounding property). Do not use misting systems, water hoses or other devices that spray liquids in Hillphoenix display cases with unapproved lighted shelves.

If a misting system or water hose is installed or used on a display case with a shelf lighting system that is not Clearvoyant™ 4 with the proper use of dielectric grease, then Hillphoenix shall not be subject to any obligations or liabilities (whether arising out of breach of contract, warranty, tort [including negligence], strict liability or other theories of law) directly or indirectly resulting from, arising out of or related to such installation or use, including, without limitation, any personal injury, death or property damage resulting from an electrical failure, fire, electric shock, or mold.

P088889D, REV 1.00

WARNING: UNDER NO CIRCUMSTANCES should any component be replaced or added without consulting Hillphoenix Field Service Engineering. Utilizing improper components may result in serious injury to persons or damage to the system.

IMPORTANT

At Hillphoenix®, the safety of our customers and employees, as well as the ongoing performance of our products, are top priorities. To that end, we include important warning messages in all Hillphoenix installation and operations handbooks, accompanied by an alert symbol paired with the word "DANGER", "CAUTION", or "ATTENTION."

All warning messages will inform you of the potential hazard; how to reduce the risk of case damage, personal injury or death; and what may happen if the instructions are not properly followed.

Hillphoenix® recommends that the installers and technicians installing and conducting maintenance of our refrigerated cases must take reasonable care of their own health and safety. As such Hillphoenix® requires the use of safety glasses, ear plugs, steel toed shoes, gloves, arm sleeves, knee guards, back supports and other such personal protective equipment as deemed reasonable for one's safety and protection during the installation and maintenance of our cases or as otherwise required by local ordinance, the general contractor or other governing authority.

DANGER

Indicates an immediate threat of death or serious injury if all instructions are not followed carefully.

CAUTION

Indicates the potential threat of injury if all instructions are not followed carefully.

ATTENTION

Indicates an important point of information that is key to ensuring proper case functionality.

Revision History

Rev.	Date	Change Description	Author
1.00	06/19/25	New manual	T.A.G.
1.01	07/24/25	Added electrical information	T.A.G.
1.02	11/13/25	Added lighting instructions and case installation information	T.A.G.
1.03	12/05/25	New dairy tech sheets, new meat tech sheets, and added O5MA/ON5MXA case options	T.A.G.
1.04	02/10/26	New tech sheets and GFCI information	T.A.G.

LIABILITY NOTICE

For Cases with Shelf Lighting Systems

Hillphoenix does NOT design any of its shelf lighting systems or any of its display cases with shelf lighting systems for direct or indirect exposure to water or other liquids. The use of a misting system or water hose on a display case with a shelf lighting system, resulting in the direct or indirect exposure of the lighting system to water, can lead to several serious issues (including, without limitation, electrical failures, fire, electric shock, and mold) in turn resulting in personal injury, death, sickness, and/or serious property damage (including, without limitation, to the display itself, to the location where the display is situated [e.g., store] and to any surrounding property). DO NOT use misting systems, water hoses, or other devices that spray liquids in Hillphoenix display cases with lighted shelves. If a misting system or water hose is installed or used on a display case with a shelf lighting system, then

Hillphoenix shall not be subject to any obligations, damages, or liabilities (whether arising out of breach of contract, warranty, tort [including negligence], strict liability, or other theories of law) directly or indirectly resulting from, arising out of, or related to such installation or use, including, without limitation, any personal injury, death or property damage resulting from an electrical failure, fire, electric shock, or mold.

P079211M, REVO

WARNING: UNDER NO CIRCUMSTANCES should any component be replaced or added without consulting Hillphoenix Field Service Engineering. Utilizing improper components may result in serious injury to persons or damage to the system.



CAUTION!

Under no circumstance should any component be replaced or added without consulting Hillphoenix Field Service Engineering. Utilizing improper components may result in serious injury to persons or damage to the refrigeration system.

Thank you for choosing Hillphoenix for your food merchandising needs. This manual contains important technical information and will assist you with the installation and operation of your new Hillphoenix refrigerated display cases. By closely following the instructions, you can expect peak performance; attractive fit and finish; and long case life.

We are always interested in your suggestions for improvements (e.g. case design, technical documents, etc.). Please feel free to contact our Marketing Services group at the number listed below. Thank you for choosing Hillphoenix, and we wish you the very best in outstanding food merchandising.

CASE DESCRIPTION

This manual specifically covers the O5DMA, O5MA, ON5DMXA, and ON5MXA self-contained multi-deck merchandisers.

STORE CONDITIONS

Hillphoenix cases are designed to operate in an air-conditioned store that maintains a 75 °F (24 °C) store temperature and 55% (max) relative humidity (CRMA conditions). Case operation will be adversely affected by exposure to excessively high ambient temperatures and/or humidity.

REFRIGERATION SYSTEM OPERATION

Air-cooled condensing units require adequate ventilation for efficient performance. Minimum condensing temperatures should be no less than 70 °F.

THIS UNIT CONTAINS R-290 FLAMMABLE REFRIGERANT. USE CAUTION WHEN HANDLING, MOVING, OR SERVICING THE DISPLAY CASE. AVOID DAMAGING THE REFRIGERANT TUBING WHICH COULD INCREASE THE RISK OF A LEAK.

SHIPPING CASES

Transportation companies assume all liability from the time a shipment is received by them until the time it is delivered to the consumer. Our liability ceases at the time of shipment.

RECEIVING CASES

Examine fixtures carefully and in the event of shipping damage and/or shortages, please contact the Service Parts Department at the number listed to the right.

CASE DAMAGE

Claims for obvious damage must be 1) noted on either the freight bill or the express receipt and 2) signed by the carrier's agent; otherwise, the carrier may refuse the claim. If damage becomes apparent after the equipment is unpacked, retain all packing materials and submit a written request to the carrier for inspection within 14 days of receipt of the equipment.

Failure to follow this procedure will result in refusal by the carrier to honor any claims with a consequent loss to the consumer.

If a UPS shipment has been damaged, retain the damaged material, the carton and notify us at once. We will file a claim.

LOST/MISSING ITEMS

Equipment has been carefully inspected to insure the highest level of quality. Any claim for lost/missing items must be made to Hillphoenix within 48 hours of receipt of the equipment. When making a claim please use the number listed below.

SERVICE PARTS & TECHNICAL SUPPORT

For service parts questions regarding our cases, please contact our Service Parts Department at 1-833-372-7871 or orderparts@doverfoodretail.com

For technical questions regarding our cases, please contact our Technical Support Department at 1-833-280-5714.

CONTACTING THE FACTORY

If you need to contact Hillphoenix regarding a specific fixture, be certain that you have both the case model number and serial number. This information can be found on the data tag, located at the top-left interior, rear exterior panel or interior rear lower storage of the case. *Location may vary based on case design.* When you have this information, call the toll-free number listed above.

Hillphoenix
1925 Ruffin Mill Rd
Colonial Heights, VA 23834
Mon.-Fri. (8 a.m. to 5 p.m.)
Tel: 804-526-4455/Fax: 804-526-1926
www.hillphoenix.com

CASE INSTALLATION

FLOOR PREP

1. Confirm with the general contractor that you have the most current building dimensions, then ask for the points of reference from which you should take dimensions to locate the cases.
2. Using chalk lines or a laser transit, mark the floor where the cases are to be located for the entire lineup. The lines should coincide with the outside edges of the case feet.
3. Leveling is necessary to ensure proper case alignment and to avoid potential case damage. Locate the highest point on the positioning lines as a reference for determining the proper height of the shim-pack levelers. A laser transit is recommended for precision and requires just one person.
4. Locate the basehorse positions along the chalk lines, then spot properly leveled shim packs at each location.

LINE-UP & INSTALLATION

Single Case

1. Roll the case into position, leaving a minimum of 2" between the wall and the back of the case. This space must be kept unobstructed in order to provide sufficient room for airflow behind the case.
2. Using a "J" bar, raise the end of the case (under cross support), remove the caster assembly (Fig. 1) and lower the basehorse on to the shim packs. Repeat on the other end of the case.
3. Once the basehorse is properly placed on the shim packs, check the vertical plumb of the case by placing

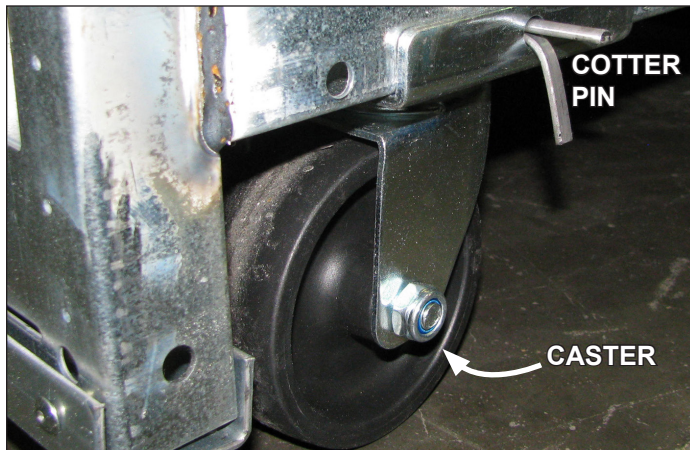

Fig. 1 Flatten and remove the cotter pins that are holding the casters in place, then lift the case with a "J" bar and slide the caster assemblies out. The dismantled casters can now be discarded.



CAUTION!

Be certain that your hands and feet are out of the way before lowering the case after the removal of the casters. Failure to do so may result in serious injury.

a bubble level on the shelf standard. Add/remove shim packs as needed. For the horizontal level, repeat this process after placing the bubble level on the front sill.

Multi-Case

1. Remove any shelves (discard the shelf clips) and/or loose items (e.g. shipping braces, mirror assemblies, etc) from the cases that may interfere with case joining. Keep all loose items as they may be used later in the installation process.
2. Remove the return air grill at the case joint. The grill lifts out without fasteners and may be easily removed to gain clear access to the case-to-case joining bolts.
3. Follow the single-case installation instructions for the first case, then position the next case in the line-up approximately 3' away. Remove the casters on the end that is closest to the first case.
4. Apply the foam tape gasket (supplied) and a bead of butyl or silicone sealant to the end of the first case (Fig. 2). From the opposite end, push the second case to a position that is approximately 6" from the first case, then remove the remaining casters and position case on the shim packs.
5. Push the cases tightly together, then lightly bolt them together through the holes that are provided (Fig. 2). Tighten all the joining bolts until all margins are equal. Be careful not to over tighten.

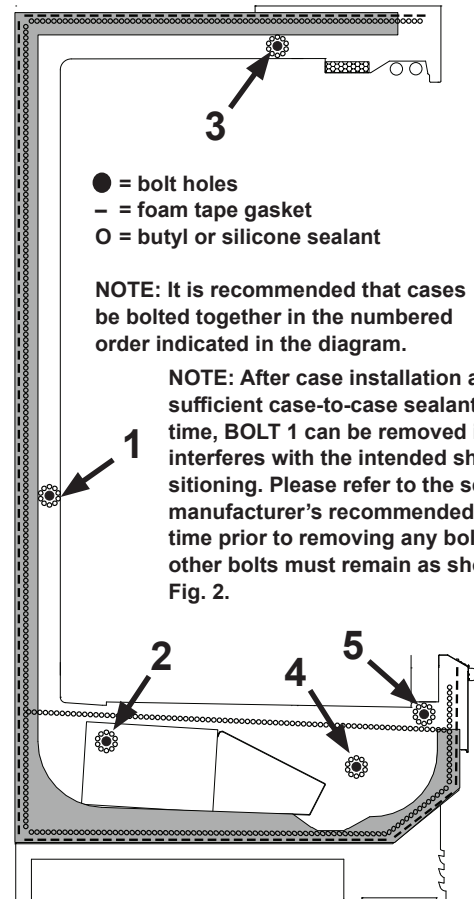

Fig. 2 Bolt holes, foam tape gasket, and sealant

- Repeat steps 3-6 of this sequence for all remaining cases. Be certain to properly level all cases.
- See **Appendix E** for seismic bracket installation instructions.

Condensate Tubing Installation

Objective

To install and route condensate tubing from the pump (with tank) to the CDU evaporator pan, ensuring proper drainage and secure fastening for stable operation across O(N)5DM(X) A 4' and 6' units.

Required Components

- Submersible pump with tank (115V, 60Hz)
- Clear tubing (3/8" O.D., supplied with pump kit)
- Clamps for securing hose
- Power source for pump (115V connection)
- Pump tube fitting and 90 degree brass elbow

Installation Steps

- Position condensate tank and pump
 - Ensure the pump condensate tank is level and stable.
 - Submerge the pump inside the tank completely.



Tank Capacity:
2.0 US quart (1.9 liters)

- Connect tubing
 - Ensure the pump tube fitting and 90 degree brass elbow is threaded to the pump outlet.
 - Attach the clear tubing (3/8" O.D.) to the pump outlet fitting.
 - Cut tubing to the required length to reach from the pump outlet to the inside of the condensate evaporator heater pan.
 - Ensure a snug fit at the outlet to prevent leaks.
- Route tubing
 - Gently route the tubing from the tank toward the condensate evaporator heater pan via the cutout provided on the rear fascia panel.
 - Avoid sharp bends or kinks to maintain smooth condensate flow.
- Secure tubing
 - Guide the 3/8" clear tubing from the pump outlet through the rear fascia cutout toward the drain evaporator heater pan.
- Electrical connection
 - Connect the pump to a 115V power source.
 - Verify pressure-activated switch operation.
 - Pump activates at ~1.6" water level.
 - Pump shuts off at ~1.3" water level.
- Final checks
 - Confirm tubing is securely fastened with no movement or sagging.
 - Pour water into the tank to activate the pump and verify flow into the CDU pan.
 - Inspect for leaks, misalignment, or hose movement.
 - Ensure pump cycles correctly and tubing remains secure.

Fig. 3 Condensate tubing components

Tube/Hose Routing : Pump to Drain Evaporator Heater Pan

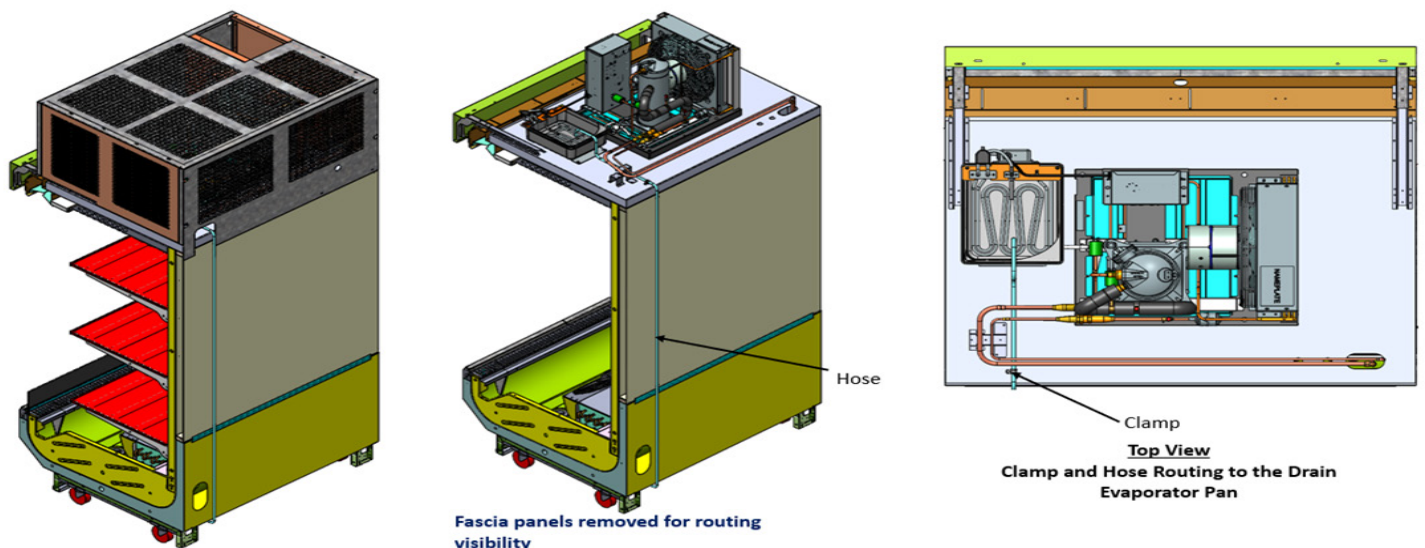

Fig. 4 Routing for tube/hose

CASE INSTALLATION

TRIM OUT

1. Seal the interior case-to-case joints with caulk (supplied), then apply acrylic tape (supplied) over the pipe-chase seam (Fig. 5). The tape acts as a watershed preventing water from settling in the case joint.
2. If mirror assemblies and mirror scoops are ordered, see **Appendix G** for installation instructions.
3. Re-install shelves (or peg hook assemblies if applicable). Be aware that differing shelf configurations will

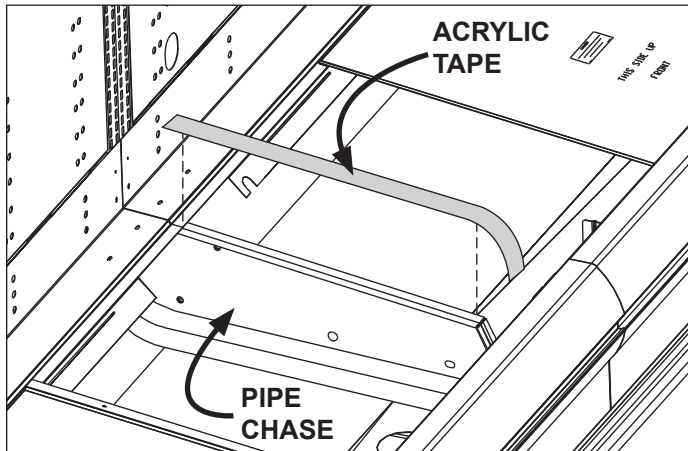

Fig. 5 Sealing the pipe chase

affect energy consumption and case performance. If shelf fillers are ordered, see **Appendix H** for installation instructions. If peg hook assemblies are ordered, see **Appendix I** for installation instructions.

4. Install the cornice joint trim (Fig. 6).



Fig. 6 Cornice joint trim

5. Properly align the front panels as needed, then install the front panel trim (supplied) behind the loosened bumper track (Fig. 7).

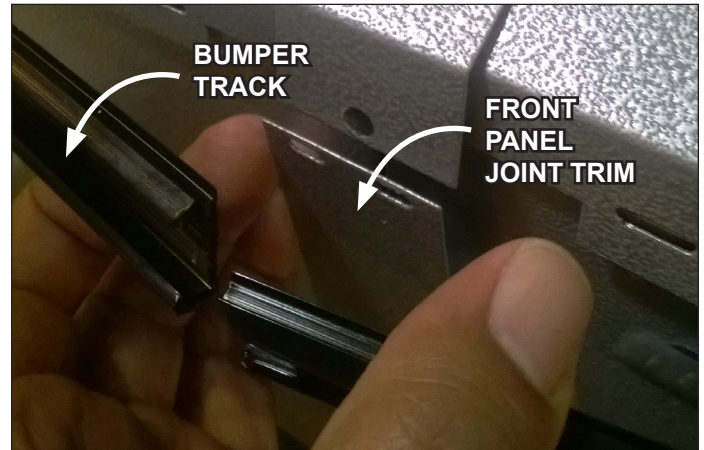

Fig. 7 Front panel trim is installed behind bumper track

6. The upper and lower kickplate assemblies are shipped loose in the case. Install the upper kickplate retainer onto the kickplate supports using the provided screws (Fig. 8). Then slide the top edge of the lower kickplate up under the edge of the upper kickplate retainer (Fig. 9)—when the lower kickplate is flat against the base-frame feet, lower it to the floor to complete the installation.

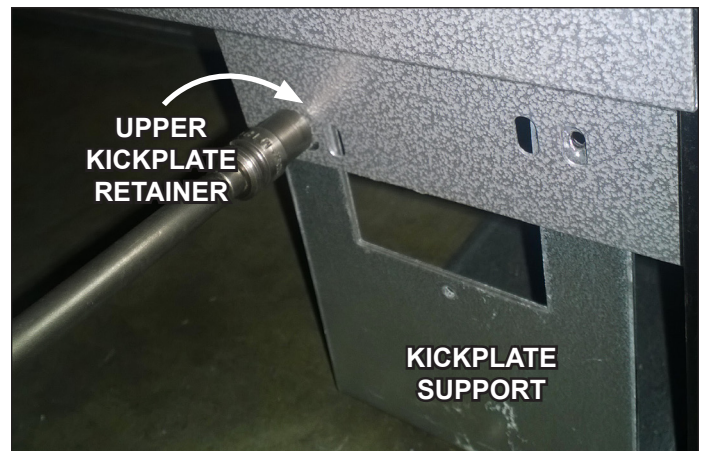

Fig. 8 Install the upper kickplate onto kickplate support

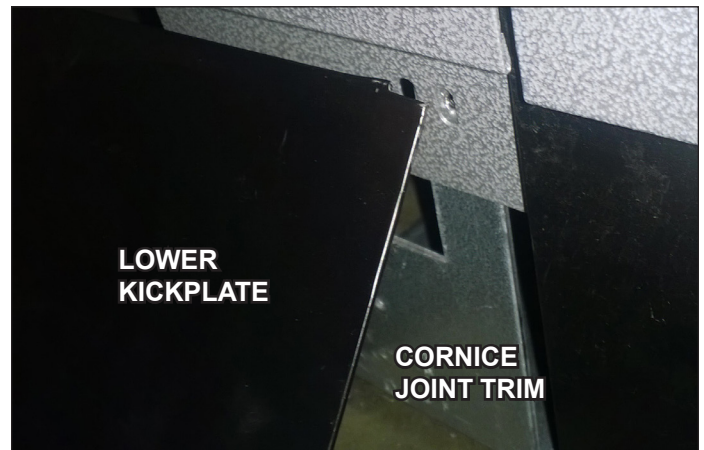

Fig. 9 Lower kickplate slides up behind upper kickplate retainer

7. End kickplates are shipped loose. Attach to the base-frames directly under the ends with the screws that are provided, then cover the screws with the two painted plug buttons that are provided.
8. Install the H-channel trim to join the acrylic front sill glass pieces (if present) of adjoining cases (Fig. 10).

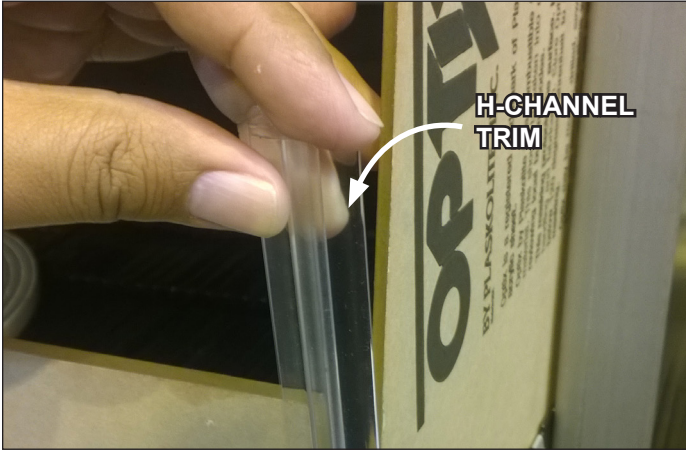

Fig. 10 H-channel trim joins front sill glass pieces

9. Install the snap-on track bumper (Fig. 11) onto the track, up to 96 feet. For rigid bumper, cut for as tight a fit as possible—to allow for minor shrinkage following start-up—and install. For rolled bumper, Hillphoenix recommends leaving an additional 6 inches of nose bumper at the ends to allow for shrinkage during the first 24–48 hours following case start-up—after sufficient time has passed, cut away the excess bumper for final fit and finish. Be certain to use an appropriate cutting tool (tubing- or PVC-cutter) to ensure a smooth cut.



Fig. 11 Leave 6 inches of extra bumper

CASE CONNECTIONS



ATTENTION!

Connections are illustrated in dimensional drawings found on pages 3 & 5.

REFRIGERATION

The condensing unit (Fig. 12) is located on top of the case for easy access. Refrigerant piping runs down the rear of the case to and from the coil.

The expansion valve and other controls, which are located on the left-hand side of the case, are accessed by lifting the left-hand deck pans—lifting the fan plenum is not required.

Before operating the case, be certain to remove any shipping blocks that protect the refrigeration lines during shipping. If it becomes necessary to penetrate the case tank in any area, be certain to seal any open gaps afterwards with canned-foam sealant and white RTV.

PLUMBING

The drain outlet is specially molded out of PVC material and is located in the front-center of the case for convenient access. The “P” trap, furnished with the case, is constructed of schedule 40 PVC pipe (Fig. 13). Case run-off should be channeled to a floor drain located underneath the case.

Since the kickplate is shipped loose with the case, you should have open access to the drain line area during installation. If the kickplate has been installed, you will find it easy to remove. Simply pull the bottom of the lower kickplate out-and-away from the case—disengaging it from the upper kickplate—and remove. If necessary, remove the screws securing the upper kickplate to the kickplate retainer and remove (see Trim Out instructions on page 4).

Care should be given to ensure that all connections are water-tight and sealed with the appropriate PVC or ABS cement.

ELECTRICAL

Electrical connections are made in the electrical junction box located at the top rear-left of the case (Fig. 14). This self-contained multi-deck merchandiser uses a Carel MPXzero case controller. For more detailed electrical wiring information, see **Appendix B**. For more detailed information on the Carel MPXzero controller and setpoints, see **Appendix C**.



DANGER!

SHOCK HAZARD

Always disconnect power to case when servicing or cleaning. Failure to do so may result in serious injury or death.

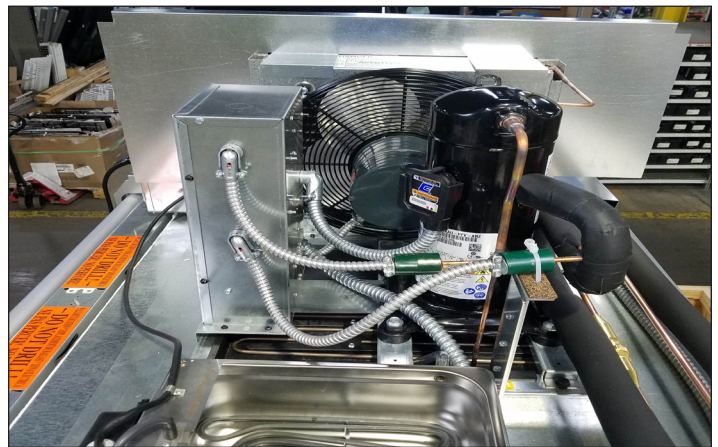

Fig. 12 Condensing unit on top of case

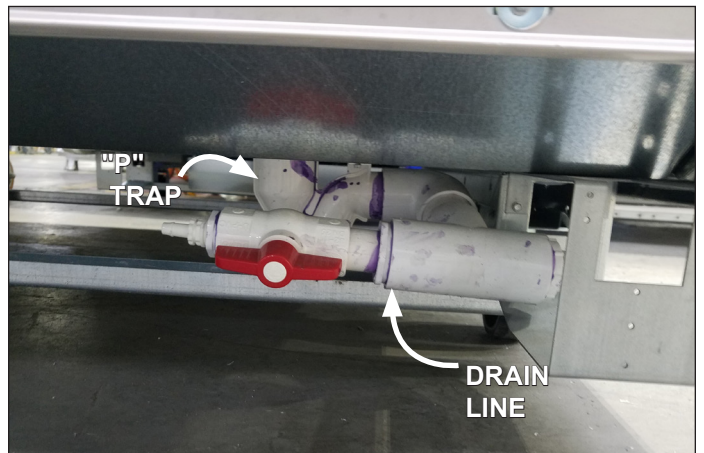

Fig. 13 “P” trap; drain line



Fig. 14 Electrical junction box on top of case



ATTENTION!

If brazing is necessary, place wet rags around the area to avoid tank damage.



ATTENTION!

Be certain that all piping and electrical connections comply with local codes.



CAUTION

This case must be powered only in electrical installations with ground fault circuit interrupter (GFCI) circuit breakers or residual current device (RCD).

MPXzero Lighting Schedule Setup Guide

1. Download the Carel phone application **Applica**.
 2. Open **Applica** on your device.
 3. Select **Bluetooth** and connect to the desired controller.
- Tip: Hold the device in close proximity to the desired controller to ensure the intended case is being edited.*
4. When prompted for a profile, select **Manufacturer**.
 5. Enter **44** as the password when prompted.

Note: If “44” is not accepted, leave the password field blank.

6. Open the menu using the hamburger icon (☰) in the top left corner.
7. Select **Parameter List** from the menu options.
8. Select **DAY/NIGHT** from the parameter options at the top.

Note: There are 8 total time bands available. Start times are labeled as “tSx” and “tEx” are labeled as end times, where “x” ranges from 1 to 8.

9. For each time band, choose the “-d” (**days**) option and select the **All Days** option.

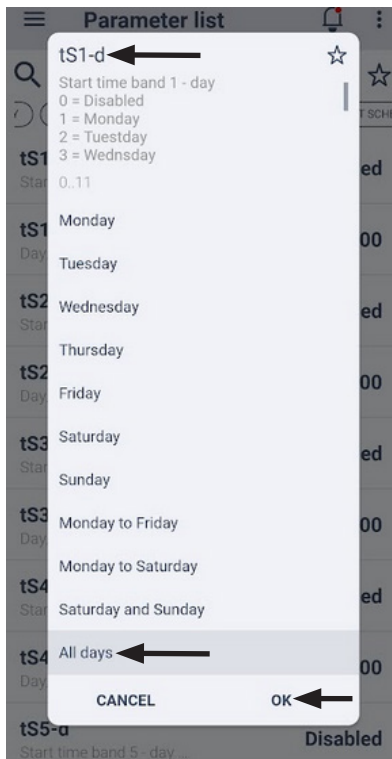

Fig. 15 Time band details

10. To set the lighting start times, choose the “-time” option for each **tSx** parameter and enter the desired start time for lighting.

11. To set the lighting end times, choose the “-time” option for each **tEx** parameter and enter the desired end time for lighting.

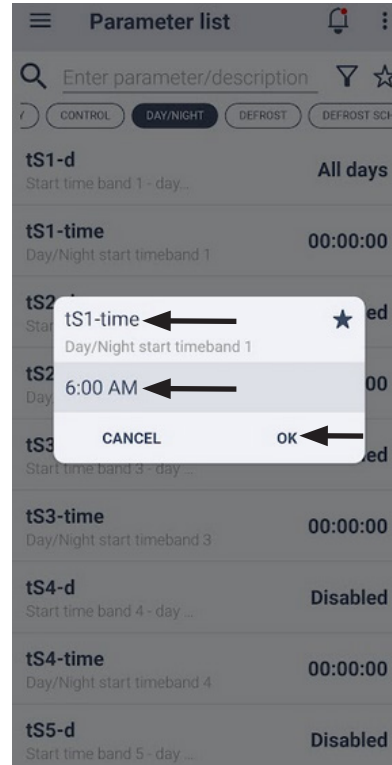

Fig. 16 Day start timeband example

12. When finished, open the menu (☰) and select **Disconnect**.

13. Select **Yes** to disconnect.

CASE CONNECTIONS



ATTENTION!

If lifted through the base feet, pallet blades must extend past the second set of base feet on the case.

CDU and Fascia Removal Procedure

Note: The case and condensing unit are shipped charged with refrigerant.

Note: Installers are responsible to comply with all OSHA, local, and store safety requirements. Installers are also responsible for providing equipment adequately sized for the task.

Tools Required

- Screwdriver (Phillips/Flat Head, as applicable): 1/4" Hex Head, 1/2" Hex Head
- Nut Driver/Wrench Set (refer to technical specifications for sizes): 7/8", 15/16"
- Protective Gloves
- Refrigerant Recovery Equipment (if disconnecting refrigerant lines)

Preparation

- Disconnect power at the electrical panel (breaker box) and lock out/tag out the source to prevent accidental energization.
- Shut off refrigeration supply and return valves.
- Allow the system to equalize pressure before handling any connections. This is a critical safety step to prevent refrigerant release.

Fascia Panel Removal

Top Fascia Panel Removal

The top fascia panel covers the CDU and associated piping connections. To remove, locate and unscrew/unfasten all securing screws or fasteners. Carefully lift the panel and set it aside in a safe location. Removing the top fascia will expose the CDU, piping, and other internal components.

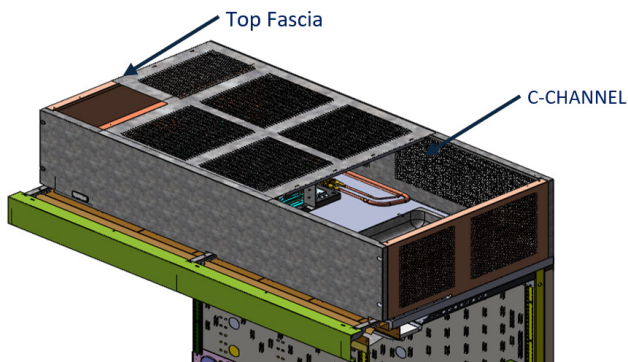

Fig. 17 Top fascia panel

C-Channel Removal (6' O(N)5DMXA Units Only)

6' Standard and Narrow O5DM units are equipped with a C-channel that supports the top fascia. The C-channel must also be removed during top fascia removal. Note that 4' units do not have a C-channel.

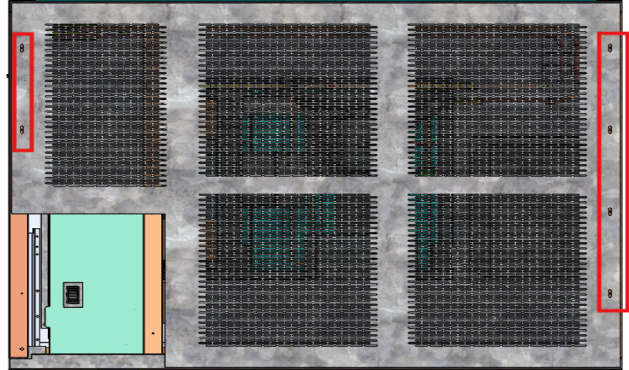

Fig. 18 4' case canopy view

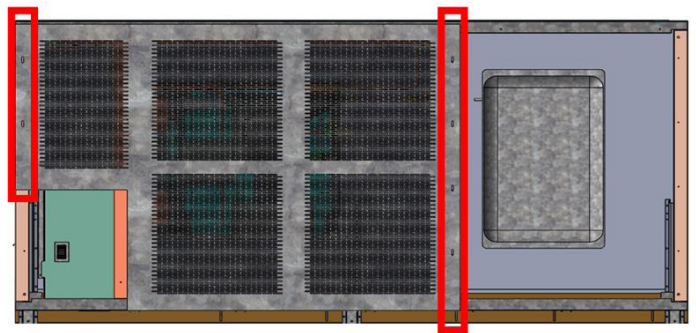

Fig. 19 6' case canopy view

Front Fascia Panel

Locate and remove the screws securing the front fascia panel. Gently disengage the panel from its clips and set it aside in a safe location to avoid damage.

Rear Fascia Panel

Remove the mounting screws from the rear fascia panel. Once the screws are removed, lift and remove the panel.

Side Panels

Remove the fasteners from both the left and right side panels. Once the fasteners are removed, slide the panels outward and set them aside.

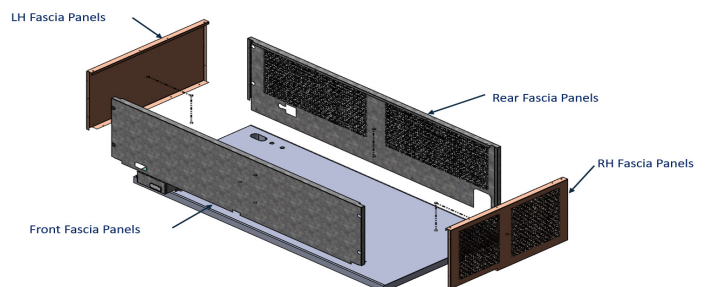

Fig. 20 Canopy level paneling

Drain Pan Removal

1. Disconnect the condensate drain hose from the CDU drain pan.
2. Locate and remove the screws (4) securing the drain pan to the canopy assembly.
3. Carefully lower and remove the drain pan. It may contain residual water, so handle with care. Place it in a safe location to avoid damage.

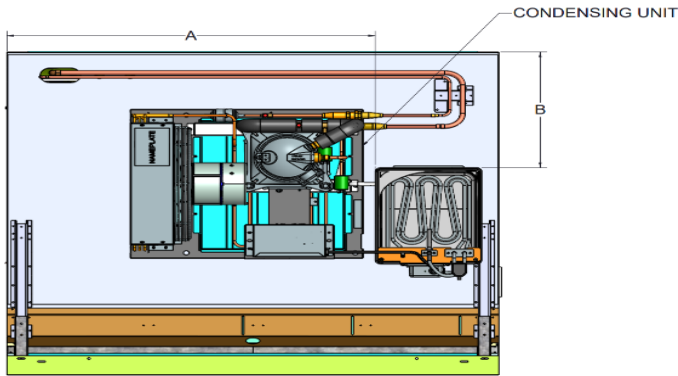

Fig. 21 Electric drain pan location

CDU Removal

1. Unplug the CDU power cord from the junction box (JBOX) or receptacle. The JBOX is located on the front left side of the unit when facing it (refer to the technical drawing for guidance).
2. Safely disconnect the refrigerant line connections using proper refrigerant recovery procedures and equipment in accordance with EPA guidelines. Ensure all refrigerant is fully recovered before proceeding.
3. Unscrew and remove the screw securing the air coil block cover on the structural member aligned with the CDU's condenser coil area.
4. Remove the four (4) screws at the corners of the CDU base that secure it to the canopy. These screws act as the main hold points for the unit.
5. With the help of a second person or appropriate lifting equipment, carefully slide the CDU forward and lift it off the canopy assembly. The CDU is heavy, so follow proper lifting techniques to avoid injury. Place the unit in a safe location for future installation.

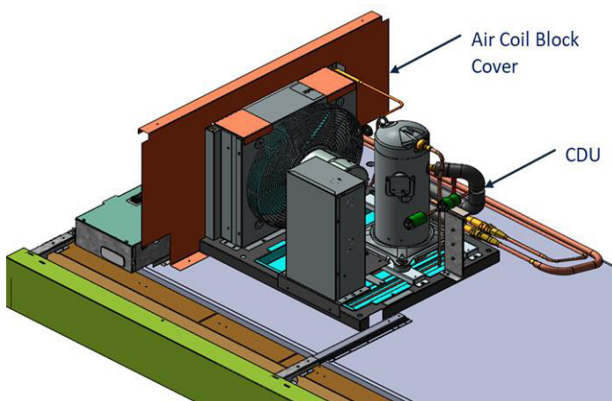

Fig. 22 Installed CDU with air block

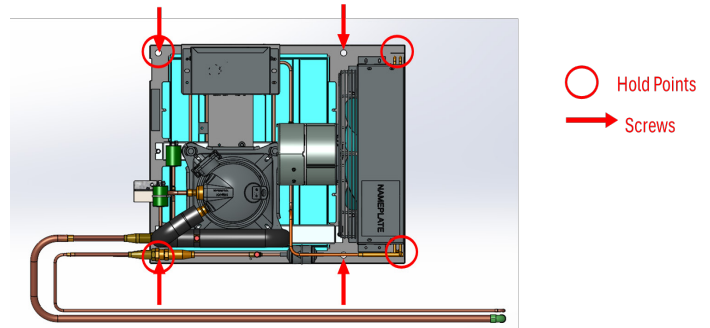

Fig. 23 CDU mounting locations and hold points

Reinstallation Notes

1. Place the CDU onto the canopy and secure it with the four mounting screws. Ensure the unit is properly aligned before fully tightening the screws.
2. Reattach the air coil block cover and secure it with its screw on the structural member aligned with the CDU's condenser coil area.
3. Reconnect the refrigerant lines, power cord, and condensate hose to the drain pan.
4. Reinstall the side panels, rear fascia, and front fascia in the reverse order of removal.
5. Verify that all refrigerant, drain, and electrical connections are secure and leak-free. Replace any damaged seals or gaskets before powering on the unit.
6. Once the CDU is fully reassembled, proceed with system startup and commissioning procedures as outlined in the full manual.

PRE-POWER CHECKLIST

Before powering-up the case, be certain that all of the steps listed below have been completed to ensure proper case functionality, safety and compliance with warranty terms.

- Have you thoroughly examined the case for shipping damage? (see pg. 1)
- Have you removed and discarded the casters? (see pg. 2)
- Have you checked the vertical plumb of the case? The horizontal level? (see pg. 2)
- Have you applied the foam tape gasket and sealant between adjoining cases? (see pg. 2)
- Have you sealed the case-to-case joints by applying caulk and acrylic tape to the pipe-chase seam? (see pg. 3)
- Have you sealed any tank penetrations? (see pg. 5)



ATTENTION!

Be certain to clear the case of any loose packaging or case materials before energizing the case. Failure to do so may result in case damage or malfunction.



DANGER!

SHOCK HAZARD

Always disconnect power to case when servicing or cleaning. Failure to do so may result in serious injury or death.

Hillphoenix cases may be equipped with LED luminaires. LED power supplies operate both the **center sill** lights and shelf lights and are located in the **center sill** area, above the light reflectors.



CAUTION!

During replacement of ballasts/power supplies, always confirm that the new ballasts/power supplies are the correct replacement parts. Failure to do so may result in damage to the LED system or the luminaires, leading to poor performance and increased risk of safety issues.

LED lighting systems has an ON/OFF switch that is located in the upper left-hand corner of the lighting assembly. Once cases have been properly positioned in the store and an electrician has connected the lighting circuit, the lights may be turned on to verify that they are connected and functioning properly.

To ensure peak performance, it is advisable to run the lighting systems only when the store climate control is on and case refrigeration is started. NOTE: it is highly recommended that the ambient store temperature **not** exceed 80°F.

REPLACING SHELF LED LUMINAIRES

1. Unplug the LED luminaire (Fig. 24).
2. Pinching the latching clips inward at the ends of the luminaire, rotate luminaire down at each end until hooks



Fig. 24 Unplug the LED luminaire

are free, then remove (Fig. 25).

3. To install the new luminaire, place hook into shelf roll at shelf front and rotate rear of luminaire toward the shelf.
4. Depress the rear clip so that luminaire can finish rotation and until clip engages the shelf bracket.

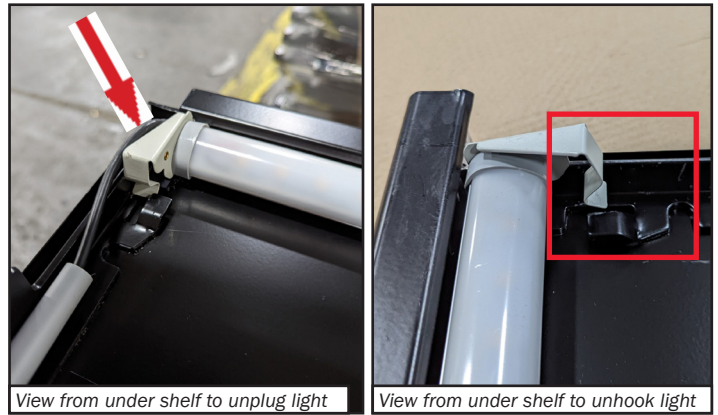

View from under shelf to unplug light
View from under shelf to unhook light
Fig. 25 Removing shelf lights

REPLACING NON-SHELF LED LUMINAIRES

1. Squeeze plastic clips on the four-pin connector at the end of the luminaire, then pull free of the receptacle (Fig. 26).
2. At the other end, slide the luminaire to the opening and disengage from the metal housing slot.
3. To install the new luminaire, simply reverse the previous steps.



Fig. 26 Squeeze the latching clips and pull the luminaire free

LIGHTING & POWER SUPPLIES

ACCESSING BALLASTS/POWER SUPPLIES

Ballasts or power supplies are housed behind the light reflectors and may be easily removed by following these instructions:

1. Remove LED luminaires as described earlier in this section.
2. Light reflectors are held in place by screws located along the back edge of the reflector. Remove the screws and while maintaining a secure grip on the reflector, swing the loose edge down until the ballasts/power supplies are visible on the back-side.
3. Disengage the front edge of the light reflector by lifting it free of the front channel hinge, then carefully remove. Ballasts/power supplies will now be visible on the back-side of the reflector (Fig. 27).
4. To re-install the reflector, secure the front edge of the reflector over the front channel hinge, swing the back edge up into place, then replace the screws along the back edge of the reflector.

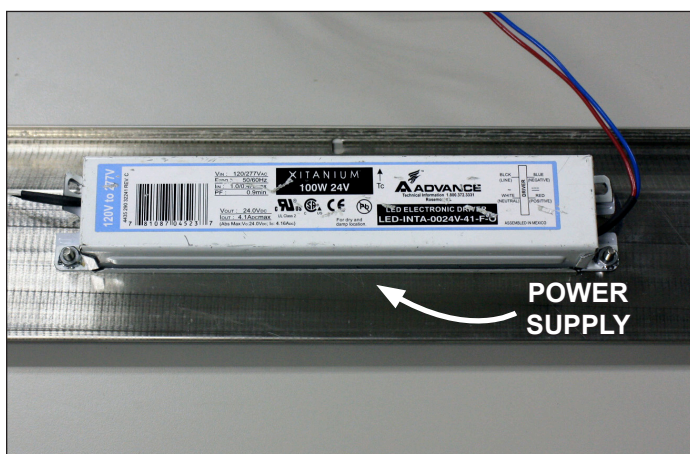

Fig. 27 Clear view of the power supply on the back side of the light reflector



ATTENTION!

If fascia is installed on top of the case, do not drill into the area above the ballast(s). Doing so may result in case damage.

AIR FLOW & PRODUCT LOAD

Do not overload the food product display so that it impinges on the air flow pattern—doing so will result in diminished performance and loss of proper temperature levels, particularly when the discharge honeycomb and return air grille are covered. Please keep products within the load limit line shown on the diagram below (Fig. 28).

DEFROST & TEMPERATURE CONTROLS

Hillphoenix cases utilize electric, hot gas, or timed-off defrost. The primary components used for the defrost cycle are the various defrost termination sensors, which work to terminate the defrost cycle in the case.

O5DMA and ON5DMXA cases utilize timed-off defrost. The defrost termination sensor is located on left end of coil. With timed-off defrost, the refrigeration cycle is simply turned off by the case controls for a specified amount of time; therefore, there are generally no active defrost components utilized.

For more detailed information on suggested defrost times and settings, see pages 2 & 4. Further adjustment may be required depending on store conditions.

DETERMINING SUPERHEAT

To identify the correct superheat settings, complete the following steps:

1. Obtain suction pressure from the access port. Obtain the suction line temperature from the area near the TXV bulb at the outlet of the evaporator coil.
2. Using the suction pressure reading and the Sporlan® temperature-pressure chart (**Appendix D**), convert pressure-to-temperature.
3. Finally, subtract the converted temperature reading from the actual temperature reading. The resulting number is the superheat setting—once this has been determined, adjust the TXV as needed to obtain the proper setting.

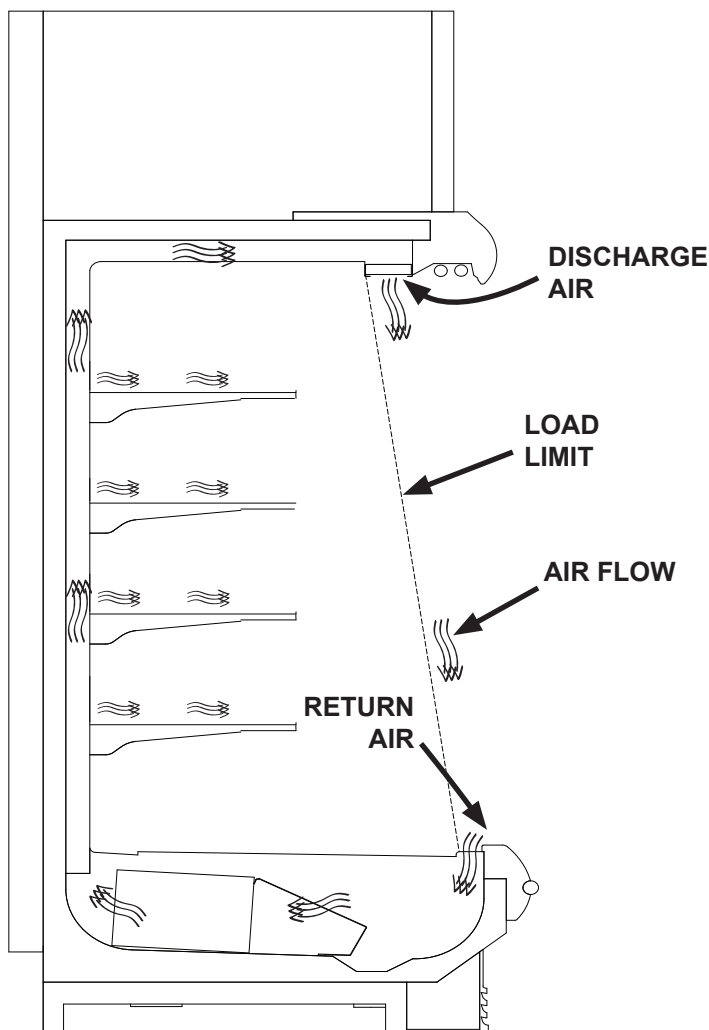

Fig. 28 Airflow

FANS & CASE CLEANING



DANGER!

SHOCK HAZARD

Always disconnect power to case when servicing or cleaning. Failure to do so may result in serious injury or death.



CAUTION!

Exercise extreme caution when working in a case with the coil cover removed. The coil contains many sharp edges that can cause severe cuts to the hands and arms.

FANS

The fans are 8" in diameter. It is important that the fan speed be maintained as specified. Do not attempt a field modification by altering the fan speed as this will affect case performance.

Fan motors may be changed with an easy two-step process without lifting up the plenum, thereby avoiding the necessity to unload the entire product display to change the fan assembly:

1. Unplug the fan motor (Fig. 29), easily accessible outside the plenum. Be certain to push the power cord back through the plenum opening to avoid damage to the power cord.
2. Remove fasteners, then lift out the entire fan basket.

Reverse procedure when re-installing fan basket.

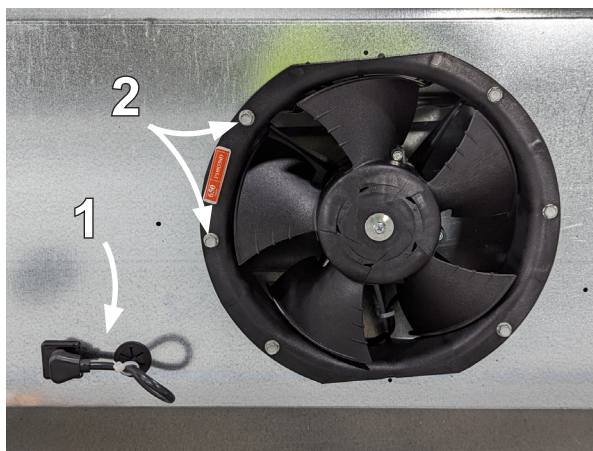

Fig. 29 Fan basket



ATTENTION!

Power cord must be pushed back through the plenum opening before removing the fan basket. Failure to do so may result in damage to the power cord.

CLEANING PROCEDURES

A periodic cleaning schedule should be established to maintain proper sanitation, insure maximum operating efficiency, and avoid the corrosive action of food fluids on metal parts that are left on for long periods of time. We recommend cleaning once a week.

- Be certain that all electricity to the case is turned off before servicing or cleaning to avoid electrical shock. In some cases, more than one switch may need to be turned off to completely de-energize the case.
- All surfaces pitch downward to a deep-drawn drain trough, funneling liquids and other debris to the waste outlet. Check waste outlet before starting the cleaning process to insure it is unclogged. Avoid introducing water faster than the case drain can carry it away.
- Lift the fan plenum to gain access to the coil for cleaning and maintenance (Fig. 30).

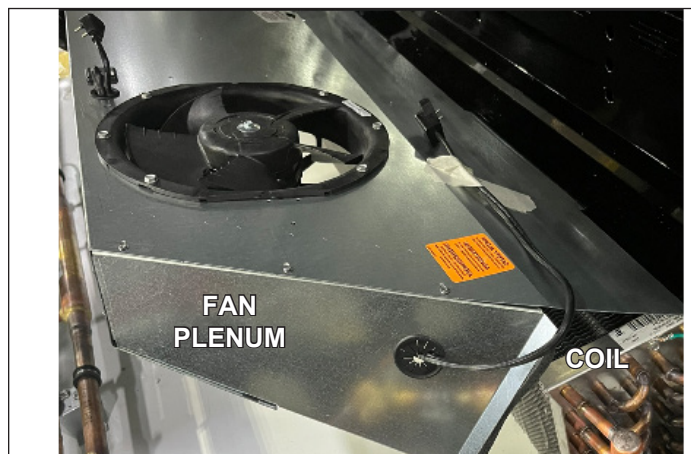

Fig. 30 Single-piece fan plenum and coil cover

- To clean the lights, shut off the lights in the case, then wipe them down with a soft, damp cloth. Avoid using harsh or abrasive cleaners as they may damage the lights. Be certain that the lights are completely dry before re-energizing.
- If any potentially harmful cleaners are used, be certain to provide a temporary separator (e.g., cardboard, plastic wrap, etc.) between those cases that are being cleaned and those that may still contain product.
- Avoid spraying cleaning solutions directly on electrical connections.
- Allow cases to be turned off long enough to clean any frost or ice from coil and pans.
- Remove kickplate and clean underneath the case with a broom and a long-handled mop. Use warm water and a disinfecting cleaning solution when cleaning underneath the cases.

PARTS SUBJECT TO WEAR & SPARE PARTS

Most spare parts carry clear, complete ID information. It is important that the refrigerated case parts be replaced by analogous parts of equivalent safety and quality: to order spare parts please contact Hillphoenix, stating the case model and serial number, found in this manual or on the case ID plate, and provide a description of the component and the desired quantity. Refer to the Parts section in the back of the manual for parts ordering and to identify parts that may need to be replaced.

CAUTION
Do not pressure wash equipment as damage to electrical components may result.

INSTRUCTIONS FOR PERSONNEL

In the Event of General Emergency

Immediately inform those in the vicinity of the perceived danger, gesticulating if necessary; cut the electrical power to the cabinet.

In the Event of Fire

In the event that the refrigerated case catches fire or is involved in a fire it is possible to use an extinguisher with a powder-type or CO2 extinguishing agent.

Resetting the Case

To restore normal operation it is necessary to eliminate all the causes of the emergency situation; if necessary repair or replace damaged parts.

Note: If safety devices are tripped it will be necessary to identify the cause before continuing work.

CAUTION
Do not store or use gasoline or other flammable vapors and liquids in the vicinity of this or any other appliance.

CAUTION
R-290 flammable refrigerant in use. Improper installation, adjustment, alteration, service or maintenance can cause property damage, injury or death. Read the installation operating and maintenance instructions thoroughly before installing or servicing this equipment.

DANGER
FLAMMABLE
DANGER - Risk of Fire or Explosion. Flammable Refrigerant Used. Do Not Use Mechanical Devices To Defrost Refrigerator. Do Not Puncture Refrigerant Tubing.



FAILURES AND TROUBLESHOOTING

Failures

In the event of a failure of mechanical/electrical/refrigeration parts the initial safety conditions must be restored immediately by replacing or repairing such faulty parts.

TABLE OF FAILURES AND TROUBLESHOOTING

PROBLEM	POSSIBLE CAUSE	SOLUTION
The refrigerated cabinet does not work.	<ol style="list-style-type: none"> 1. The main circuit breaker is set to OFF; 2. The power line between refrigerated cabinet and power socket is faulty; 3. The switch on the refrigerated cabinet control panel switch is not on. 	<ol style="list-style-type: none"> 1. Turn the main power on; 2. Make sure the plug is inserted properly in the socket; 3. Turn the power switch on the refrigerated cabinet panel ON.
The refrigeration effect of the refrigerated cabinet is poor.	<ol style="list-style-type: none"> 1. The product door is not closed tightly; 2. The product temperature is set too high. 3. The product is exposed to direct sunlight or close to hot objects; 4. The goods are placed higher than the load line 	<ol style="list-style-type: none"> 1. Close the door tightly; 2. Lower the product temperature; 3. Keep the product in a cool place; 4. Place goods below the load line
The outer surface of the product is hot.	The outer surface of the product is wrapped with a condenser, which will generate heat during refrigeration.	This phenomenon is normal.

(Cont'd) NEXT PAGE

TROUBLESHOOTING

TABLE OF FAILURES AND TROUBLESHOOTING (Cont'd)

PROBLEM	POSSIBLE CAUSE	SOLUTION
The product is noisy	<ol style="list-style-type: none"> 1. The product is in the high-frequency operation stage at the initial stage of operation; 2. The product is in the defrosting stage; 3. The product is not placed stably. 	<ol style="list-style-type: none"> 1. After one to two hours of operation, the noise will be significantly reduced; 2. The defrosting cycle of the product is 24 hours. In the defrosting stage, high noise is a phenomenon of genuine production; 3. Adjust the foot to make the cabinet stable.
Condensation occurs on the glass door	The ambient temperature and humidity of the product are too high	The operating environment of the product is 75°F/55RH. In case of excessive humidity, please wipe off the water stains on the surface with a rag.
There is peculiar smell inside the product	<ol style="list-style-type: none"> 1. New products will smell like plastic; 2. Check whether there are deteriorated goods in the cabinet; 3. The product has not been cleaned for a long time. 	<ol style="list-style-type: none"> 1. After the product is used for a period of time, the smell will disappear naturally; 2. Clean up spoiled food in time; 3. Clean the product regularly.

SAFETY DEVICES

 **WARNING**

It is absolutely forbidden for the user to tamper with safety devices. Before using the refrigerated case check that mechanical safety covers are properly in place. Any tampering shall render the warranty null and void and exonerate Hillphoenix from any liability with regard to users of the refrigerated case.

Only maintenance personnel may carry out maintenance tasks involving safety devices. These tasks are listed below:

SAFETY DEVICE	SCOPE OF INTERVENTION	ACTION
Incorporated over-pressure cut-out	On incorporated condenser unit	Cuts the electrical power of the compressor if the pressure of the refrigerant rises above the safety limits.
Ignition proof zone established around electrical junction box	On incorporated Condensing unit Condensor Fan	Prevents leak access to electrical components. Fans operate 100% of the times.
Case Internal leak mitigation system	External Blower system connected to the Tank drain adapter	Facilitates evacuation and dissipation of leaked charge during defrost cycle
Safety Housing (on cases with greater than 150gm charge) to be removed with tools for servicing	Sheet metal housing on Condensing unit	Prevents access to and protects piping in the Condensing Unit
Piping Cover (on cases with greater than 150gm charge) to be removed with tools for servicing	Sheet metal housing on external Copper piping	Prevents access to and protects external piping at the rear of the case

DESCRIPTION OF RESIDUAL DANGERS AND RISK

Residual Dangers

Dangers that have not been reduced/eliminated with the safety measures adopted on the refrigerated case can nevertheless be reduced/eliminated as long as users apply proper managerial practices.

- Ensure that all safety warning and labels are always in good condition; inspect them periodically and have them replaced whenever necessary.
- Do not install any spare parts that are not identical to the originals or of equivalent performance.
- Do not carry out any modifications or structural work without approval from Hillphoenix or a qualified field service technician.

- Should the refrigerated case be dented, inspect the structure visually or have qualified personnel carry out an inspection.

After a long period of disuse have a qualified field service technician carry out an inspection of the case to check that it is in good condition and working properly.

Residual Risks

While the refrigerated case has been designed to ensure maximum safety, there nevertheless remain some residual risks. Hillphoenix has identified the main **dangers and residual risks for users and maintenance personnel** as follows in the “Scheduled Maintenance Table” on the next page.

REFRIGERANT

This piece of equipment uses an R-290 Refrigeration system. This equipment has been clearly marked on the serial tag the type of refrigerant that is being used. There is also a warning label stating that the unit contains R-290 refrigerant.

No smoking or open flames when servicing this equipment. If needed, use a Class B (CO2 or dry powder) type fire extinguisher.

Only an authorized service technician, certified in R-290 system should service this equipment.

 **DANGER**

SHOCK HAZARD

Always disconnect power to case when servicing. Failure to do so may result in injury or death.

Use an R-290 approved fan for constant ventilation while working.

- If an R-290 approved fan is not available, make sure fan is at least 10’ away from cabinet.
- Remove at least two panels from the base to allow air flow through the unit.
- Point the fan towards the bottom of the work area as R-290 is heavier than air.

The work area must be free from sources of ignition such as open flames and sparking electrical devices, like light switches. Keep a 10’ perimeter around the case of clearance.

The propane gas used in the unit has no odor. The lack of smell does not indicate a lack of escaped gas.

Recommend posting a “Flammable Refrigerant” placard in the area prior to servicing.

MANIFOLD SET

A R-134a manifold set can be used for servicing this equipment.

REFRIGERANT RECOVERY

Follow all national and local regulations for R-290 refrigerant recovery.

SCHEDULED MAINTENANCE TABLE

DESCRIPTION OF RESIDUAL RISK	CAUSE	SAFETY MEASURES
Danger of falls in area surrounding the cabinet	Presence of: stairs, columns etc. and/or slippery floors and objects and/or work tools	Mark out the relevant zones and highlight them with warning signs and symbols (e.g. yellow/black striped marker tape on stairs etc.) that are visible during both routine use and maintenance.
Danger of objects accidentally falling	Haphazard storage of tools/objects.	Use tool boxes in work areas. Ensure personnel are trained.
Danger of injury to hands, arms, legs and head	During cleaning and maintenance there may be objects or parts of the cabinet protruding from the case itself (e.g. glass covers open during cleaning)	Mark out the work area with appropriate barriers. Always use the recommended personal safety devices.
Risk of refrigerating gas leaks	Accidental damage to pipes	Immediate shutdown of case operation. Disconnect electrical power supply. Contact a service technician.

LEAKING CHECKING AND REPAIR

Leak check an R-290 system the same way you would an R-134a or R-404a system with the following exceptions.

1. Do not use a Halide leak detector on an R-290 system.
2. Electronic leak detector must be designated specifically for combustible gas.

A quality combustible gas leak detector is mandatory for hydrocarbon service work. Leak detector should be placed near the bottom of the cabinet, as R-290 is heavier than air.

When repairing a leak, it is recommended using oxygen free dry nitrogen with a trace gas not exceeding 200PSI.

When accessing an R-290 system, proper charge is to be weighed into the system and the system is to be leak checked afterwards.

The R-290 equipment must have red process tubes and other devices through which the refrigerant is serviced, such as any service port. This color marking must remain on the equipment. If marking is removed, it must be replaced and extended at

CAUTION

Component parts shall be replaced with like components. Service work shall be done by factory authorized service personnel, so as to minimize the risk of possible ignition due to incorrect parts or improper service.

CHARGING

Follow the charge amount specified on the data tag. It is recommended to use the shortest hoses possible to prevent under-charging.

- Component parts shall be replaced with like components. Service work shall be done by factory authorized service personnel, so as to minimize the risk of possible ignition due to incorrect parts or improper service.
- Ensure the system is sealed and leak checked
- Evacuate system to a minimum 500 microns
- Weigh in correct charge
- Leak check the system again
- Bleed the refrigerant from the high side hose to the low side hose
- Disconnect the hoses
- Remove line taps

DANGER

FLAMMABLE

DANGER - Risk of Fire or Explosion. Flammable Refrigerant Used. Do Not Use Mechanical Devices To Defrost Refrigerator. Do Not Puncture Refrigerant Tubing.



CHARGING PORTS

Schrader port locations across the case are red marked to highlight them as Charging ports per regulations.

⚠ WARNING
Use Caps with o-rings on Schrader Valves, post service.

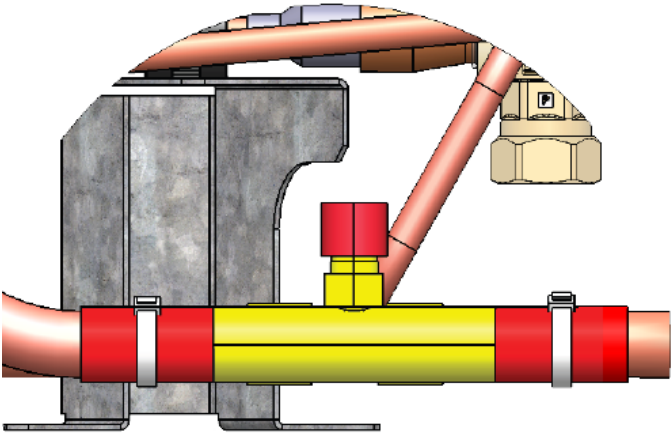

Fig. 31 Schrader port locations

⚠ CAUTION

It is highly recommended that a technician servicing a case with HC refrigerant is aware of safety considerations and maintenance procedures on how to safely handle flammable refrigerants.

DE-ICING EVENTS

Depending on the severity of the icing event, there may not be enough capacity in the pan to accommodate all of the water. The recommended procedure is for the service technician to:

- 1. Carry a 3/8" vinyl tube
- 2. Connect this tube to the outlet of the pump
- 3. Pump excess water to a drain or into a 5 gallon bucket

If the technician does not have this hose on-hand, then they can use the one attached to the pump by disconnecting it at the top of the case and reinstalling it when finished.

⚠ DANGER
FLAMMABLE
DANGER - Risk of Fire or Explosion. Flammable Refrigerant Used. Do Not Use Mechanical Devices To Defrost Refrigerator. Do Not Puncture Refrigerant Tubing.

Hillphoenix®

a **DOVER** company

Contact the Service Parts Department at:

1-833-372-7871

or

orderparts@doverfoodretail.com

Provide the following information about the part you are ordering:

- Model number and serial number* of the case for which the part is intended.
- Length of the part (if applicable).
- Color of part (if painted) or color of polymer part.
- Whether part is for left or right-hand application.
- Quantity

*Data tag is located on the left end exterior panel or top interior of the case.

If the parts are to be returned for credit, contact the Parts Department. Do not send parts without authorization.



A..... TECHNICAL REFERENCE SHEETS

B..... WIRING DIAGRAM

C..... CONTROLLERS & SETPOINTS

D..... SPORLAN CHART

E..... SEISMIC BRACKETS

F..... CASE TOP FASCIA

G..... MIRROR ASSEMBLY

H..... SHELF FILLERS

I..... PEG HOOKS

J..... PARTS LIST

O5DMA-NRG

4' & 6' Self-Contained Multi-Deck Merchandiser
Beverage/Bulk Produce/Bakery/Dairy/Cut Produce/Deli



GENERAL NOTES

- " - - -" indicates that the feature is not an option for this case model and/or the data is not yet available.
- LED lights only.
- Maximum of 6 rows of Standard Output LED lighted shelves.
- 2 rows of standard or 1 row of cornice high output LED lights only.
- NSF Type 1 – Designed to operate in an air-conditioned store that maintains a 75°F (24°C) store temperature and 55% (max) relative humidity. Case operation will be adversely affected by exposure to excessively high ambient temperatures and/or humidity.
- **WARNING:** R-290 flammable refrigerant in use. Read the installation, operating and maintenance instructions thoroughly before installing or servicing this equipment.

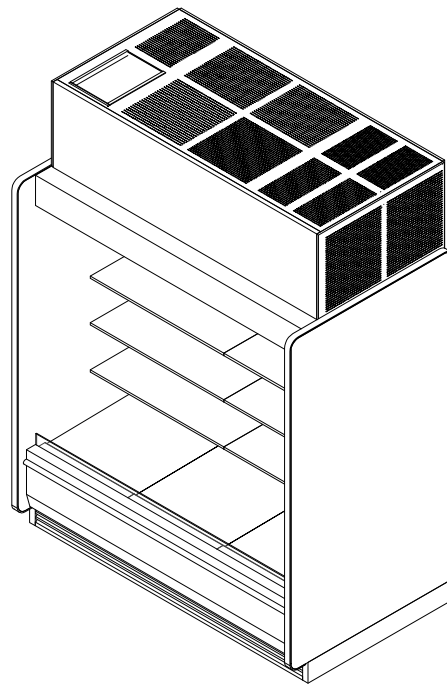

SHIPPING WEIGHT	
Case	Weight
O5DMA-NRG	---



ALL MEASUREMENTS ARE TAKEN PER ASHRAE-72 SPECIFICATIONS. HILLPHOENIX REFRIGERATED DISPLAY CASES FOR SALE IN THE UNITED STATES MEET OR EXCEED DEPARTMENT OF ENERGY 2017 REQUIREMENTS.

O5DMA-NRG

Rev. Date	Rev. #	Rev. Title
02-02-26	1	OPTIONS UPDATE
12-03-25	0	R-290 CONVERSION



O5DMA-NRG

4' & 6' Self-Contained Multi-Deck Merchandiser
Beverage/Bulk Produce/Bakery/Dairy/Cut Produce/Deli



SYSTEM REQUIREMENTS									
Case Length	Volts	Wiring Type	Phase	Frequency (Hz)	Optional Factory Installed Plug	MCA	MOP	24hr Energy Usage (kWh)	THR (BTUH)
4'	120/208	3 Wire + Gnd	1	60	NEMA L14-30	21.7	25.0	37.6	5346.0
6'	120/208	3 Wire + Gnd	1	60	NEMA L14-30	24.5	30.0	52.8	7507.0

ELECTRICAL DATA					
Case Length	Fans Per Case	High Efficiency Fans		Evaporator Pan Heater	
		120 Volts		208 Volts	
		Amps	Watts	Amps	Watts
4'	2	0.4	68.0	3.6	750
6'	2	0.4	68.0	3.6	750

LIGHTING DATA						
Case Length	Lights Per Row	Light Length	High Power (Cornice Only)		Standard Power (Cornice or Shelf)	
			120 Volts		120 Volts	
			Amps	Watts	Amps	Watts
4'	1	4'	0.12	14.90	0.05	5.90
6'	2	3'	0.20	23.80	0.08	9.40

GUIDELINES AND CONTROL SETTINGS			
Application	Superheat Set Point @ Bulb (°F)	Discharge Air (°F)	Discharge Air Velocity (FPM)
Beverage/Bulk Produce	6 - 8	34	150
Bakery/Dairy/Cut Produce/Deli	6 - 8	30	150

CONDENSING UNIT DATA								
Case Length	Volts	Phase	Frequency (Hz)	Horsepower	Running Load Amps (RLA)	Locked Rotor Amps (LRA)	Refrigerant	Refrigerant (g)
4'	208	1	60	1 1/2	10	40.3	R-290	340
6'	208	1	60	2	12	56.0	R-290	380

DEFROST CONTROLS		
Defrosts Per Day	Timed-Off Defrost	
	Fail-Safe (Min)	Termination Temp (°F)
8	30	40

NOTES:

- "----" indicates that the feature is not an option for this case model and/or the data is not yet available.
- Listed discharge air velocity represents the average velocity immediately after defrost completion using a Testo 410i vane anemometer with anemometer air scoop (HP part number P109185M) positioned adjacent to the interior edge of the discharge honeycomb
- The recommended evaporator temperature and defrost settings may need to be adjusted based on system setup, store conditions, etc. The minimum recommended evaporator temperature is 4°F below the listed evaporator temperature.
- Discharge air temperature values represent readings taken within the upper air channel immediately behind/upstream of the honeycomb.



COMPONENT
ALL MEASUREMENTS ARE TAKEN PER ASHRAE-72 SPECIFICATIONS. HILLPHOENIX REFRIGERATED DISPLAY CASES FOR SALE IN THE UNITED STATES MEET OR EXCEED DEPARTMENT OF ENERGY 2017 REQUIREMENTS.

O5DMA-NRG



Rev. Date	Rev. #	Rev. Title
02-02-26	1	OPTIONS UPDATE
12-03-25	0	R-290 CONVERSION



O5DMA-NRG

4' & 6' Self-Contained Multi-Deck Merchandiser
Beverage/Bulk Produce/Bakery/Dairy/Cut Produce/Deli

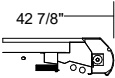

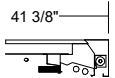
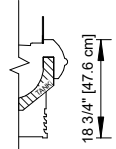
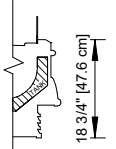
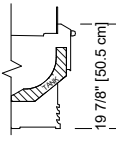
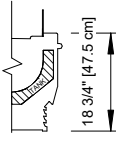
CORNICE OPTIONS			
<p><u>CURVED CORNICE</u></p>  <p>39 5/8"</p>	<p><u>CURVED CORNICE WITH NIGHT COVER</u></p>  <p>42 7/8"</p>	<p><u>FLAT CORNICE</u></p>  <p>38 3/4"</p>	<p><u>FLAT CORNICE WITH NIGHT COVER</u></p>  <p>41 3/8"</p>
FRONT OPTIONS			
<u>ORIGIN 2</u>		<u>CLASSIC 2 POLYMER</u>	
<p><u>18" FRONT</u></p>  <p>18 3/4" [47.6 cm]</p>		<p><u>18" FRONT</u></p>  <p>18 3/4" [47.6 cm]</p>	
<u>FLAT OPTION 1</u>		<u>FLAT OPTION 2</u>	
<p><u>18" FRONT</u></p>  <p>19 7/8" [50.5 cm]</p>		<p><u>18" FRONT</u></p>  <p>18 3/4" [47.5 cm]</p>	



COMPONENT

ALL MEASUREMENTS ARE TAKEN PER ASHRAE-72 SPECIFICATIONS. HILLPHOENIX REFRIGERATED DISPLAY CASES FOR SALE IN THE UNITED STATES MEET OR EXCEED DEPARTMENT OF ENERGY 2017 REQUIREMENTS.

O5DMA-NRG

Rev. Date	Rev. #	Rev. Title
02-02-26	1	OPTIONS UPDATE
12-03-25	0	R-290 CONVERSION



O5DMA-NRG

4' & 6' Self-Contained Multi-Deck Merchandiser
Beverage/Bulk Produce/Bakery/Dairy/Cut Produce/Deli

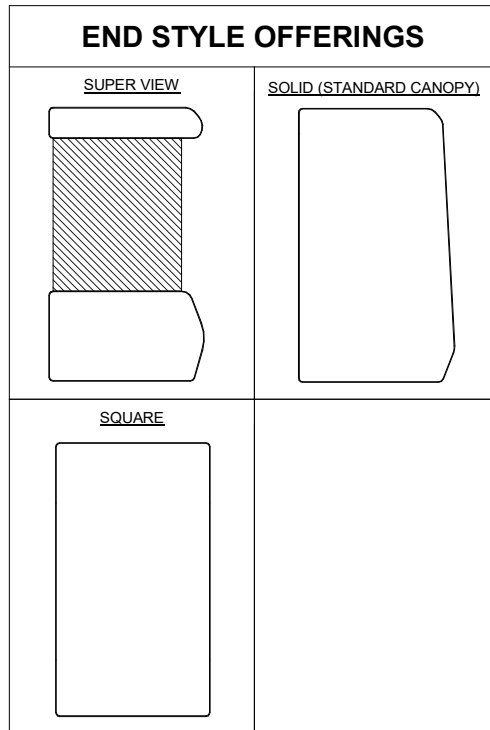

NOTES:

- Ends shown are for general use only. Shape, size, and appearance are subject to change based on engineering configuration.
- Hatched regions represent glass inserts.
- Ends are approximately 1 1/2" thick.
- Ends add approximately 1" to case height, 1/2" to the back & 1" to the front.
- Ends are available with either polymer end trim or metal end trim.
- Superview ends are not allowed on case models using the Deli application.



COMPONENT
ALL MEASUREMENTS ARE TAKEN PER ASHRAE-72 SPECIFICATIONS. HILLPHOENIX REFRIGERATED DISPLAY CASES FOR SALE IN THE UNITED STATES MEET OR EXCEED DEPARTMENT OF ENERGY 2017 REQUIREMENTS.

O5DMA-NRG

Rev. Date	Rev. #	Rev. Title
02-02-26	1	OPTIONS UPDATE
12-03-25	0	R-290 CONVERSION



O5DMA-NRG

4' & 6' Self-Contained Multi-Deck Merchandiser
Beverage/Bulk Produce/Bakery/Dairy/Cut Produce/Deli

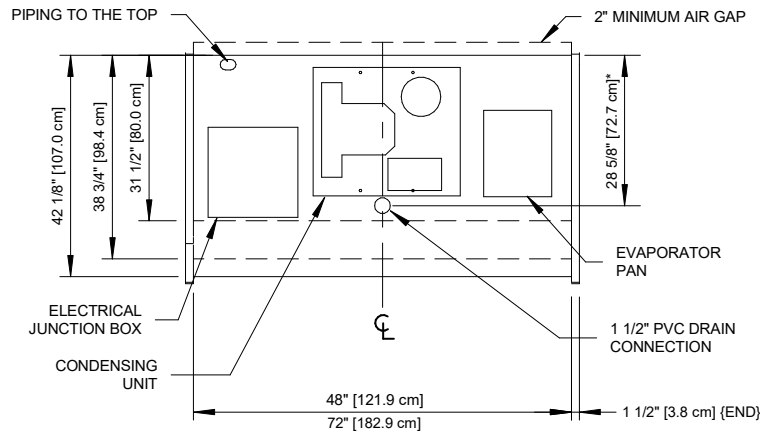
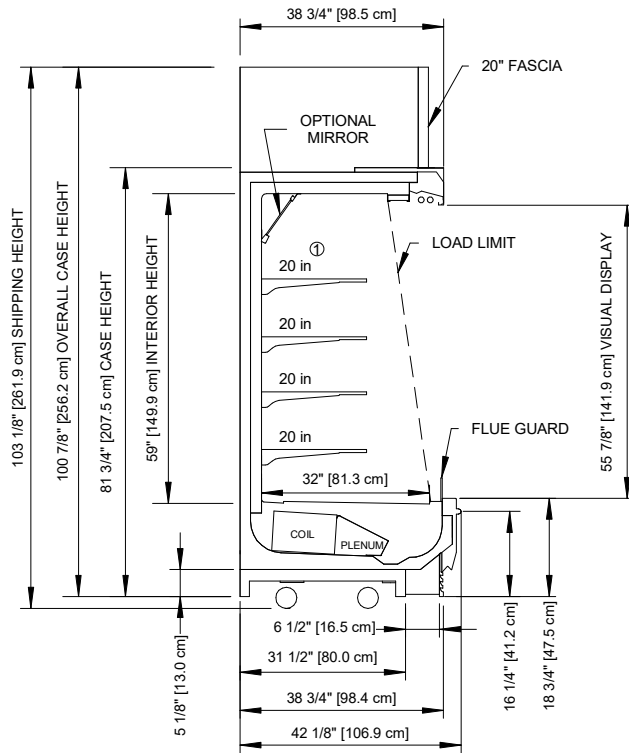

NOTES:

- * : STUB-UP AREA
- ** : RECOMMENDED STUP-UP CENTERLINE FOR ELECTRICAL AND DRAINS
- ① : AVAILABLE SHELF SIZES: 20", 22" & 24"

- Ends add approximately 1" to case height, 1/2" to the back of the case and 1" to the front of the case.
- A 12-inch minimum clearance is required above case fascia, presuming single case line-up. Consult the factory if multiple cases are being placed in the line-up.



COMPONENT
ALL MEASUREMENTS ARE TAKEN PER ASHRAE-72 SPECIFICATIONS. HILLPHOENIX REFRIGERATED DISPLAY CASES FOR SALE IN THE UNITED STATES MEET OR EXCEED DEPARTMENT OF ENERGY 2017 REQUIREMENTS.

O5DMA-NRG

Rev. Date	Rev. #	Rev. Title
02-02-26	1	OPTIONS UPDATE
12-03-25	0	R-290 CONVERSION



O5MA-NRG

4' & 6' Multi-Deck Merchandiser with Synerg-E™
Meat



GENERAL NOTES

- " - - -" indicates that the feature is not an option for this case model and/or the data is not yet available.
- LED lights only.
- Maximum of 6 rows of standard output LED lighted shelves.
- NSF Type 1 – Designed to operate in an air-conditioned store that maintains a 75°F (24°C) store temperature and 55% (max) relative humidity. Case operation will be adversely affected by exposure to excessively high ambient temperatures and/or humidity.
- WARNING: R-290 flammable refrigerant in use. Read the installation, operating and maintenance instructions thoroughly before installing or servicing this equipment.

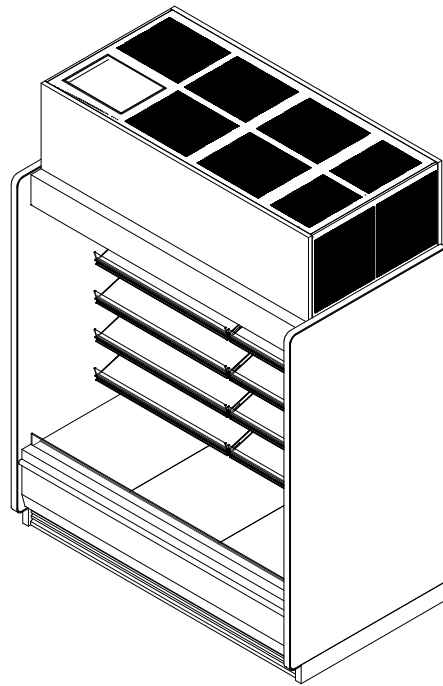

SHIPPING WEIGHT	
Case	Weight
O5MA-NRG	---



ALL MEASUREMENTS ARE TAKEN PER ASHRAE-72 SPECIFICATIONS. HILLPHOENIX REFRIGERATED DISPLAY CASES FOR SALE IN THE UNITED STATES MEET OR EXCEED DEPARTMENT OF ENERGY 2017 REQUIREMENTS.

O5MA-NRG

Rev. Date	Rev. #	Rev. Title
02-02-26	1	OPTIONS UPDATE
12-03-25	0	R-290 CONVERSION



O5MA-NRG

4' & 6' Multi-Deck Merchandiser with Synerg-E™
Meat



SYSTEM REQUIREMENTS								
Case Length	Volts	Phase	Optional Factory Installed Plug	Frequency (Hz)	MCA	MOP	24hr Energy Usage (kWh)	THR (BTUH)
4'	120/208	1	NEMA L14-30	60	21.7	25	33.9	4820.0
6'	120/208	1	NEMA L14-30	60	24.8	30	48.3	6867.0

ELECTRICAL DATA					
Case Length	Fans Per Case	High Efficiency Fans		Evaporator Pan Heater	
		120 Volts		208 Volts	
		Amps	Watts	Amps	Watts
4'	2	0.40	68	3.6	750
6'	3	0.40	68	3.6	750

LIGHTING DATA						
Case Length	Lights Per Row	Light Length	High Power (Cornice Only)		Standard Power (Cornice or Shelf)	
			120 Volts		120 Volts	
			Amps	Watts	Amps	Watts
4'	1	4'	0.5	58.8	0.05	5.9
6'	2	3'	0.8	96.0	0.08	9.4

GUIDELINES AND CONTROL SETTINGS			
Application	Superheat Set Point @ Bulb (°F)	Discharge Air (°F)	Discharge Air Velocity (FPM)
Meat	6-8	30	190

CONDENSING UNIT DATA								
Case Length	Volts	Phase	Frequency (Hz)	Horsepower	Running Load Amps (RLA)	Locked Rotor Amps (LRA)	Refrigerant	Refrigerant (g)
4'	208	1	60	1 1/2	10	40.3	R-290	340
6'	208	1	60	2	12	56.0	R-290	390

DEFROST CONTROLS			
Case Length	Defrosts Per Day	Timed-Off Defrost	
		Fail-Safe (Min)	Termination Temp (°F)
4'	8	45	45
6'	8	45	47

NOTES:

- "----" indicates that the feature is not an option for this case model and/or the data is not yet available.
- Listed discharge air velocity represents the average velocity immediately after defrost completion using a Testo 410i vane anemometer with anemometer air scoop (HP part number P109185M) positioned adjacent to the interior edge of the discharge honeycomb
- The recommended evaporator temperature and defrost settings may need to be adjusted based on system setup, store conditions, etc. The minimum recommended evaporator temperature is 4°F below the listed evaporator temperature.
- Discharge air temperature values represent readings taken within the upper air channel immediately behind/upstream of the honeycomb.
- For optimal case performance in fresh meat applications, Hillphoenix recommends that the merchandising depth in the bin area not exceed 4 inches.



ALL MEASUREMENTS ARE TAKEN PER ASHRAE-72 SPECIFICATIONS. HILLPHOENIX REFRIGERATED DISPLAY CASES FOR SALE IN THE UNITED STATES MEET OR EXCEED DEPARTMENT OF ENERGY 2017 REQUIREMENTS.

O5MA-NRG



Rev. Date	Rev. #	Rev. Title
02-02-26	1	OPTIONS UPDATE
12-03-25	0	R-290 CONVERSION



O5MA-NRG

4' & 6' Multi-Deck Merchandiser with Synerg-E™
Meat

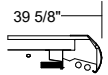
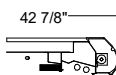

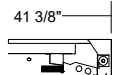
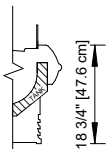
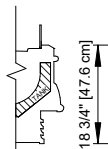
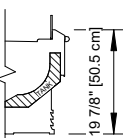
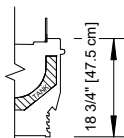
CORNICE OPTIONS			
<u>CURVED CORNICE</u>  39 5/8"	<u>CURVED CORNICE WITH NIGHT COVER</u>  42 7/8"	<u>FLAT CORNICE</u>  38 3/4"	<u>FLAT CORNICE WITH NIGHT COVER</u>  41 3/8"
FRONT OPTIONS			
<u>ORIGIN 2</u>		<u>CLASSIC 2 POLYMER</u>	
<u>18" FRONT</u>  18 3/4" [47.6 cm]		<u>18" FRONT</u>  18 3/4" [47.6 cm]	
<u>FLAT OPTION 1</u>		<u>FLAT OPTION 2</u>	
<u>18" FRONT</u>  19 7/8" [50.5 cm]		<u>18" FRONT</u>  18 3/4" [47.5 cm]	



COMPONENT
ALL MEASUREMENTS ARE TAKEN PER ASHRAE-72 SPECIFICATIONS. HILLPHOENIX REFRIGERATED DISPLAY CASES FOR SALE IN THE UNITED STATES MEET OR EXCEED DEPARTMENT OF ENERGY 2017 REQUIREMENTS.

O5MA-NRG

Rev. Date	Rev. #	Rev. Title
02-02-26	1	OPTIONS UPDATE
12-03-25	0	R-290 CONVERSION



O5MA-NRG

4' & 6' Multi-Deck Merchandiser with Synerg-E™
Meat

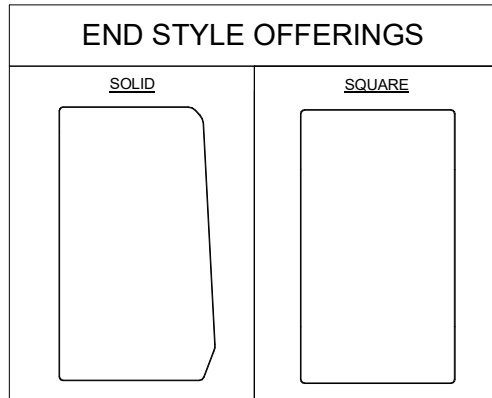

NOTES:

- Ends shown are for general use only. Shape, size, and appearance are subject to change based on engineering configuration.
- Ends are approximately 1 1/2" thick.
- Ends add approximately 1" to case height, 1/2" to the back & 1" to the front.
- Ends are available with either polymer end trim or metal end trim.



COMPONENT
ALL MEASUREMENTS ARE TAKEN PER ASHRAE-72 SPECIFICATIONS. HILLPHOENIX REFRIGERATED DISPLAY CASES FOR SALE IN THE UNITED STATES MEET OR EXCEED DEPARTMENT OF ENERGY 2017 REQUIREMENTS.

O5MA-NRG

Rev. Date	Rev. #	Rev. Title
02-02-26	1	OPTIONS UPDATE
12-03-25	0	R-290 CONVERSION



O5MA-NRG

4' & 6' Multi-Deck Merchandiser with Synerg-E™
Meat

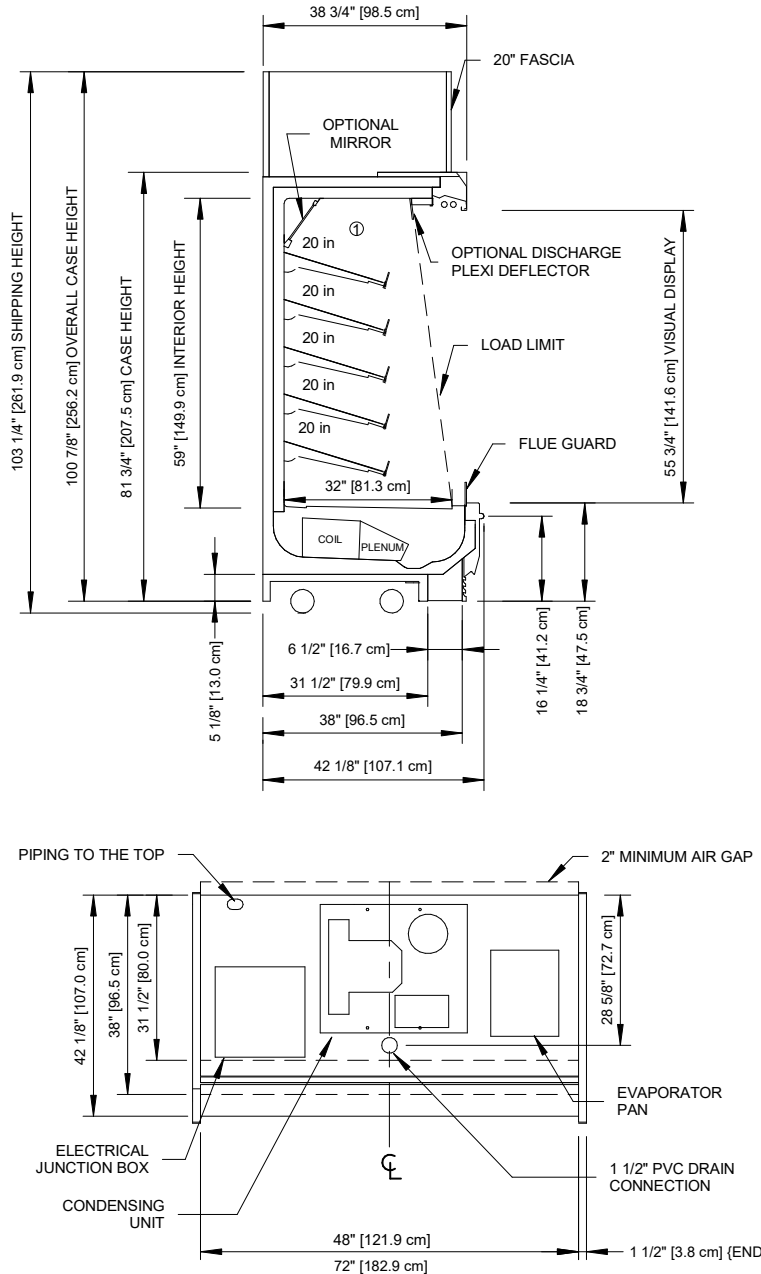

NOTES:

* : STUB-UP AREA

** : RECOMMENDED STUB-UP CENTERLINE FOR ELECTRICAL AND HUB DRAINS

Ⓛ : AVAILABLE SHELF SIZES: 20"

- Ends add approximately 1" to case height, 1/2" to the back of the case and 1" to the front of the case.
- A 12-inch minimum clearance is required above case fascia, presuming single case line-up. Consult the factory if multiple cases are being placed in the line-up.



COMPONENT

ALL MEASUREMENTS ARE TAKEN PER ASHRAE-72 SPECIFICATIONS. HILLPHOENIX REFRIGERATED DISPLAY CASES FOR SALE IN THE UNITED STATES MEET OR EXCEED DEPARTMENT OF ENERGY 2017 REQUIREMENTS.

O5MA-NRG

Rev. Date	Rev. #	Rev. Title
02-02-26	1	OPTIONS UPDATE
12-03-25	0	R-290 CONVERSION



a ROVER company

ON5DMXA-NRG

4' & 6' Narrow Self-Contained Multi-Deck Merchandiser
Beverage/Bulk Produce/Bakery/Dairy/Cut Produce/Deli



GENERAL NOTES

- "-" indicates that the feature is not an option for this case model and/or the data is not yet available.
- LED lights only.
- Maximum of 6 rows of Standard Output LED lighted shelves.
- 2 rows of standard or 1 row of cornice high output LED lights only.
- NSF Type 1 – Designed to operate in an air-conditioned store that maintains a 75°F (24°C) store temperature and 55% (max) relative humidity. Case operation will be adversely affected by exposure to excessively high ambient temperatures and/or humidity.
- **WARNING:** R-290 flammable refrigerant in use. Read the installation, operating and maintenance instructions thoroughly before installing or servicing this equipment.

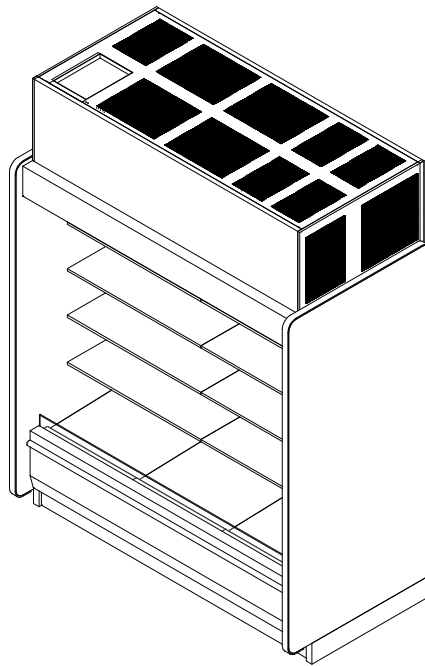

SHIPPING WEIGHT	
Case	Weight
ON5DMXA-NRG	---



ALL MEASUREMENTS ARE TAKEN PER ASHRAE-72 SPECIFICATIONS. HILLPHOENIX REFRIGERATED DISPLAY CASES FOR SALE IN THE UNITED STATES MEET OR EXCEED DEPARTMENT OF ENERGY 2017 REQUIREMENTS.

ON5DMXA-NRG

Rev. Date	Rev. #	Rev. Title
02-02-26	1	OPTIONS UPDATE
12-03-25	0	R-290 CONVERSION



ON5DMXA-NRG

4' & 6' Narrow Self-Contained Multi-Deck Merchandiser
Beverage/Bulk Produce/Bakery/Dairy/Cut Produce/Deli



SYSTEM REQUIREMENTS

Case Length	Volts	Wiring Type	Phase	Frequency (Hz)	Optional Factory Installed Plug	MCA	MOP	24hr Energy Usage (kWh)	THR (BTUH)
4'	120/208	3 Wire + Gnd	1	60	NEMA L14-30	21.7	25.0	37.6	5346.0
6'	120/208	3 Wire + Gnd	1	60	NEMA L14-30	24.5	30.0	52.8	7507.0

ELECTRICAL DATA

Case Length	Fans Per Case	High Efficiency Fans		Evaporator Pan Heater	
		120 Volts		208 Volts	
		Amps	Watts	Amps	Watts
4'	2	0.4	68.0	3.6	750
6'	2	0.4	68.0	3.6	750

LIGHTING DATA

Case Length	Lights Per Row	Light Length	High Power (Cornice Only)		Standard Power (Cornice or Shelf)	
			120 Volts		120 Volts	
			Amps	Watts	Amps	Watts
4'	1	4'	0.12	14.90	0.05	5.90
6'	2	3'	0.20	23.80	0.08	9.40

GUIDELINES AND CONTROL SETTINGS

Application	Superheat Set Point @ Bulb (°F)	Discharge Air (°F)	Discharge Air Velocity (FPM)
Beverage/Bulk Produce	6 - 8	34	150
Bakery/Dairy/Cut Produce/Deli	6 - 8	30	150

CONDENSING UNIT DATA

Case Length	Volts	Phase	Frequency (Hz)	Horsepower	Running Load Amps (RLA) (Amps)	Locked Rotor Amps (LRA) (Amps)	Refrigerant	Refrigerant (g)
4'	208	1	60	1 1/2	10	40.3	R-290	340
6'	208	1	60	2	12	56.0	R-290	380

DEFROST CONTROLS

Defrosts Per Day	Timed-Off Defrost	
	Fail-Safe (Min)	Termination Temp (F)
8	30	40

NOTES:

- "-" indicates that the feature is not an option for this case model and/or the data is not yet available.
- Listed discharge air velocity represents the average velocity immediately after defrost completion using a Testo 410i vane anemometer with anemometer air scoop (HP part number P109185M) positioned adjacent to the interior edge of the discharge honeycomb
- The recommended evaporator temperature and defrost settings may need to be adjusted based on system setup, store conditions, etc. The minimum recommended evaporator temperature is 4°F below the listed evaporator temperature.
- Discharge air temperature values represent readings taken within the upper air channel immediately behind/upstream of the honeycomb.



COMPONENT
ALL MEASUREMENTS ARE TAKEN PER ASHRAE-72 SPECIFICATIONS. HILLPHOENIX REFRIGERATED DISPLAY CASES FOR SALE IN THE UNITED STATES MEET OR EXCEED DEPARTMENT OF ENERGY 2017 REQUIREMENTS.

ON5DMXA-NRG

Rev. Date	Rev. #	Rev. Title
02-02-26	1	OPTIONS UPDATE
12-03-25	0	R-290 CONVERSION



ON5DMXA-NRG

4' & 6' Narrow Self-Contained Multi-Deck Merchandiser
Beverage/Bulk Produce/Bakery/Dairy/Cut Produce/Deli



CORNICE OPTIONS			
<p><u>CURVED CORNICE</u></p> <p>37"</p>	<p><u>CURVED CORNICE WITH NIGHT COVER</u></p> <p>40 1/4"</p>	<p><u>FLAT CORNICE</u></p> <p>36 1/8"</p>	<p><u>FLAT CORNICE WITH NIGHT COVER</u></p> <p>38 3/4"</p>
FRONT OPTIONS			
<u>ORIGIN 2</u>		<u>CLASSIC 2 POLYMER</u>	
<p><u>18" FRONT</u></p> <p>18 3/4" [47.6 cm]</p>		<p><u>18" FRONT</u></p> <p>18 3/4" [47.6 cm]</p>	
<u>FLAT OPTION 1</u>		<u>FLAT OPTION 2</u>	
<p><u>18" FRONT</u></p> <p>19 7/8" [50.5 cm]</p>		<p><u>18" FRONT</u></p> <p>18 3/4" [47.5 cm]</p>	



COMPONENT

ALL MEASUREMENTS ARE TAKEN PER ASHRAE-72 SPECIFICATIONS. HILLPHOENIX REFRIGERATED DISPLAY CASES FOR SALE IN THE UNITED STATES MEET OR EXCEED DEPARTMENT OF ENERGY 2017 REQUIREMENTS.

ON5DMXA-NRG

Rev. Date	Rev. #	Rev. Title
02-02-26	1	OPTIONS UPDATE
12-03-25	0	R-290 CONVERSION



ON5DMXA-NRG

4' & 6' Narrow Self-Contained Multi-Deck Merchandiser
Beverage/Bulk Produce/Bakery/Dairy/Cut Produce/Deli

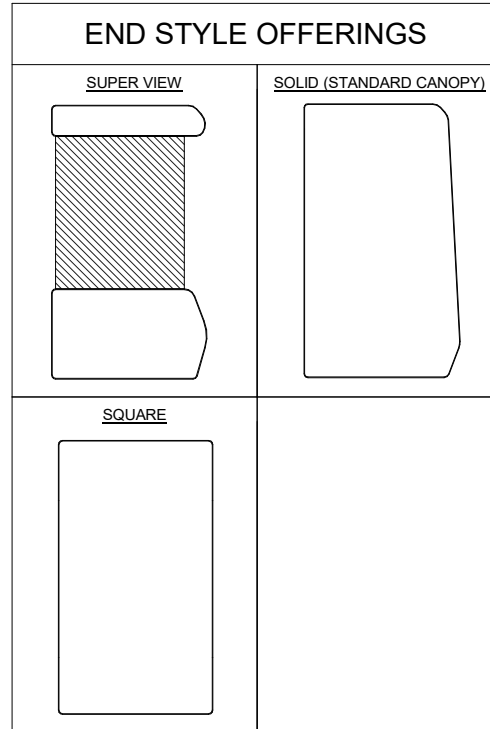

NOTES:

- Ends shown are for general use only. Shape, size, and appearance are subject to change based on engineering configuration.
- Hatched regions represent glass inserts.
- Ends are approximately 1 1/2" thick.
- Ends add approximately 1" to case height, 1/2" to the back & 1" to the front.
- Ends are available with either polymer end trim or metal end trim.
- Superview ends are not allowed on case models using the Deli application.



COMPONENT
ALL MEASUREMENTS ARE TAKEN PER ASHRAE-72 SPECIFICATIONS. HILLPHOENIX REFRIGERATED DISPLAY CASES FOR SALE IN THE UNITED STATES MEET OR EXCEED DEPARTMENT OF ENERGY 2017 REQUIREMENTS.

ON5DMXA-NRG

Rev. Date	Rev. #	Rev. Title
02-02-26	1	OPTIONS UPDATE
12-03-25	0	R-290 CONVERSION



ON5DMXA-NRG

4' & 6' Narrow Self-Contained Multi-Deck Merchandiser
Beverage/Bulk Produce/Bakery/Dairy/Cut Produce/Deli

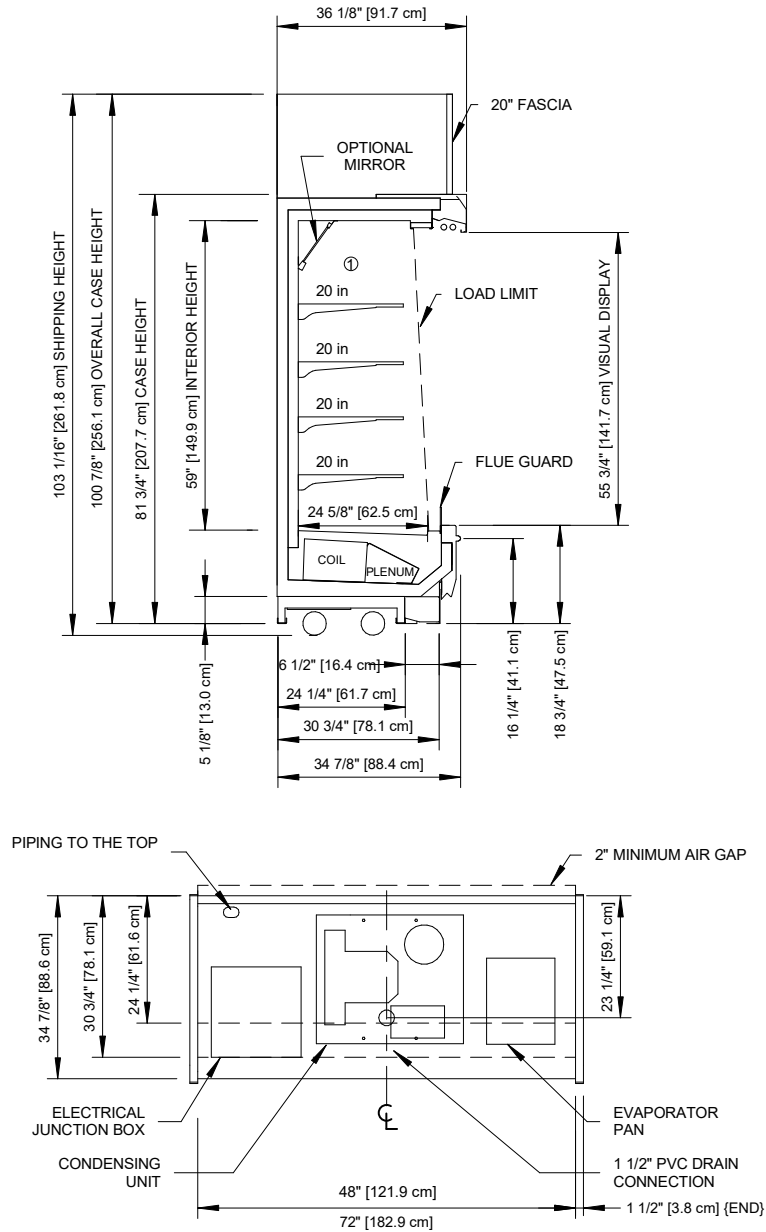

NOTES:

- * :STUB-UP AREA
- ** :RECOMMENDED STUP-UP CENTERLINE FOR ELECTRICAL AND HUB DRAINS
- ① : AVAILABLE SHELF SIZES: 20" & 22"

- Ends add approximately 1" to case height, 1/2" to the back of the case and 1" to the front of the case.
- A 12-inch minimum clearance is required above case fascia, presuming single case line-up. Consult the factory if multiple cases are being placed in the line-up.



COMPONENT
ALL MEASUREMENTS ARE TAKEN PER ASHRAE-72 SPECIFICATIONS. HILLPHOENIX REFRIGERATED DISPLAY CASES FOR SALE IN THE UNITED STATES MEET OR EXCEED DEPARTMENT OF ENERGY 2017 REQUIREMENTS.

ON5DMXA-NRG

Rev. Date	Rev. #	Rev. Title
02-02-26	1	OPTIONS UPDATE
12-03-25	0	R-290 CONVERSION



ON5MXA-NRG

4' & 6' Multi-Deck Merchandiser with Synerg-E™
Meat



GENERAL NOTES

- " - - - " indicates that the feature is not an option for this case model and/or the data is not yet available.
- LED lights only.
- Maximum of 6 rows of standard output LED lighted shelves.
- NSF Type 1 – Designed to operate in an air-conditioned store that maintains a 75°F (24°C) store temperature and 55% (max) relative humidity. Case operation will be adversely affected by exposure to excessively high ambient temperatures and/or humidity.
- **WARNING:** R-290 flammable refrigerant in use. Read the installation, operating and maintenance instructions thoroughly before installing or servicing this equipment.

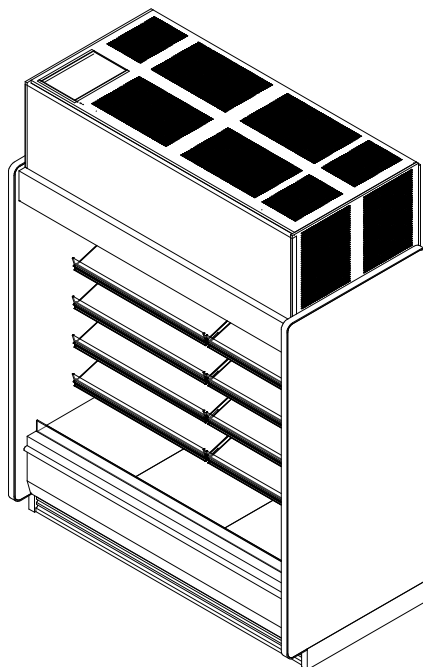

SHIPPING WEIGHT	
Case	Weight
ON5MXA-NRG	---



COMPONENT

ALL MEASUREMENTS ARE TAKEN PER ASHRAE-72 SPECIFICATIONS. HILLPHOENIX REFRIGERATED DISPLAY CASES FOR SALE IN THE UNITED STATES MEET OR EXCEED DEPARTMENT OF ENERGY 2017 REQUIREMENTS.

ON5MXA-NRG

Rev. Date	Rev. #	Rev. Title
02-02-26	1	OPTIONS PAGE
12-03-25	0	R-290 CONVERSION



a **DAVEY** company

ON5MXA-NRG

4' & 6' Multi-Deck Merchandiser with Synerg-E™
Meat



SYSTEM REQUIREMENTS

Case Length	Volts	Phase	Frequency (Hz)	Optional Factory Installed Plug	MCA	MOP	24hr Energy Usage (kWh)	THR (BTUH)
4'	120/208	1	60	NEMA-L14-30	21.7	25	34.5	4905.0
6'	120/208	1	60	NEMA-L14-30	24.8	30	46.8	6654.0

ELECTRICAL DATA

Case Length	Fans Per Case	High Efficiency Fans		Evaporator Pan Heater	
		120 Volts		208 Volts	
		Amps	Watts	Amps	Watts
4'	2	0.4	68.0	3.6	750
6'	4	0.4	68.0	3.6	750

LIGHTING DATA

Case Length	Lights Per Row	Light Length	High Power (Cornice Only)		Standard Power (Cornice or Shelf)	
			120 Volts		120 Volts	
			Amps	Watts	Amps	Watts
4'	1	4'	0.12	14.90	0.05	5.90
6'	2	3'	0.20	23.80	0.08	9.40

GUIDELINES AND CONTROL SETTINGS

Application	Superheat Set Point @ Bulb (°F)	Discharge Air (°F)	Discharge Air Velocity (FPM)
Meat	10-12	30	190

CONDENSING UNIT DATA

Case Length	Volts	Phase	Frequency (Hz)	Horsepower	Running Load Amps (RLA) (Amps)	Locked Rotor Amps (LRA) (Amps)	Refrigerant	Refrigerant (g)
4'	208	1	60	1 1/4	10	40.3	R-290	340
6'	208	1	60	1 3/4	12	56.0	R-290	380

DEFROST CONTROLS

Case Length	Defrosts Per Day	Timed-Off Defrost	
		Fail-Safe (Min)	Termination Temp (F)
4'	8	45	47
6'	8	45	47

NOTES:

- "----" indicates that the feature is not an option on this case model and/or the data is not available at this time.
- Listed discharge air velocity represents the average velocity immediately after defrost completion using a Testo 410i vane anemometer with anemometer air scoop (HP part number P109185M) positioned adjacent to the interior edge of the discharge honeycomb
- Discharge air temperature values represent readings taken within the upper air channel immediately behind/upstream of the honeycomb.
- The recommended evaporator temperature and defrost settings may need to be adjusted based on system setup, store conditions, etc. The minimum recommended evaporator temperature is 4°F below the listed evaporator temperature.
- For optimal case performance in fresh meat applications, Hillphoenix recommends that the merchandising depth in the bin area not exceed 4 inches.



COMPONENT
ALL MEASUREMENTS ARE TAKEN PER ASHRAE-72 SPECIFICATIONS. HILLPHOENIX REFRIGERATED DISPLAY CASES FOR SALE IN THE UNITED STATES MEET OR EXCEED DEPARTMENT OF ENERGY 2017 REQUIREMENTS.

ON5MXA-NRG

Rev. Date	Rev. #	Rev. Title
02-02-26	1	OPTIONS PAGE
12-03-25	0	R-290 CONVERSION



ON5MXA-NRG

4' & 6' Multi-Deck Merchandiser with Synerg-E™
Meat



CORNICE OPTIONS			
<p><u>CURVED CORNICE</u></p> <p>37"</p>	<p><u>CURVED CORNICE WITH NIGHT COVER</u></p> <p>40 1/4"</p>	<p><u>FLAT CORNICE</u></p> <p>36 1/8"</p>	<p><u>FLAT CORNICE WITH NIGHT COVER</u></p> <p>38 3/4"</p>
FRONT OPTIONS			
<p><u>ORIGIN 2</u></p> <p>18" FRONT</p> <p>18 3/4" [47.6 cm]</p>		<p><u>CLASSIC 2 POLYMER</u></p> <p>18" FRONT</p> <p>18 3/4" [47.6 cm]</p>	
<p><u>FLAT OPTION 1</u></p> <p>18" FRONT</p> <p>19 7/8" [50.5 cm]</p>		<p><u>FLAT OPTION 2</u></p> <p>18" FRONT</p> <p>18 3/4" [47.5 cm]</p>	



COMPONENT
ALL MEASUREMENTS ARE TAKEN PER ASHRAE-72 SPECIFICATIONS. HILLPHOENIX REFRIGERATED DISPLAY CASES FOR SALE IN THE UNITED STATES MEET OR EXCEED DEPARTMENT OF ENERGY 2017 REQUIREMENTS.

ON5MXA-NRG

Rev. Date	Rev. #	Rev. Title
02-02-26	1	OPTIONS PAGE
12-03-25	0	R-290 CONVERSION



ON5MXA-NRG

4' & 6' Multi-Deck Merchandiser with Synerg-E™
Meat

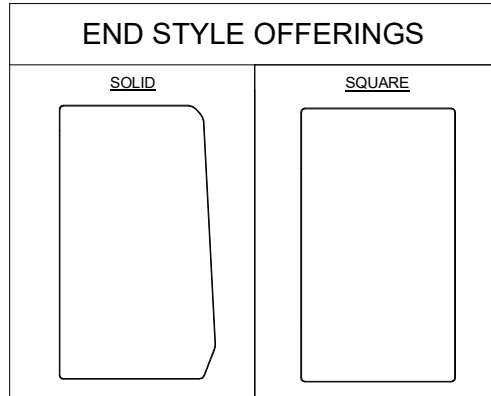

NOTES:

- Ends shown are for general use only. Shape, size, and appearance are subject to change based on engineering configuration.
- Ends are approximately 1 1/2" thick.
- Ends add approximately 1" to case height, 1/2" to the back & 1" to the front.
- Ends are available with either polymer end trim or metal end trim.



COMPONENT
ALL MEASUREMENTS ARE TAKEN PER ASHRAE-72 SPECIFICATIONS. HILLPHOENIX REFRIGERATED DISPLAY CASES FOR SALE IN THE UNITED STATES MEET OR EXCEED DEPARTMENT OF ENERGY 2017 REQUIREMENTS.

ON5MXA-NRG

Rev. Date	Rev. #	Rev. Title
02-02-26	1	OPTIONS PAGE
12-03-25	0	R-290 CONVERSION



ON5MXA-NRG

4' & 6' Multi-Deck Merchandiser with Synerg-E™
Meat

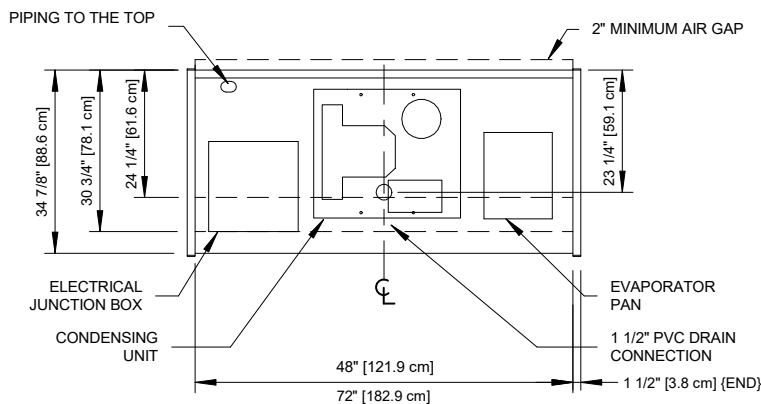
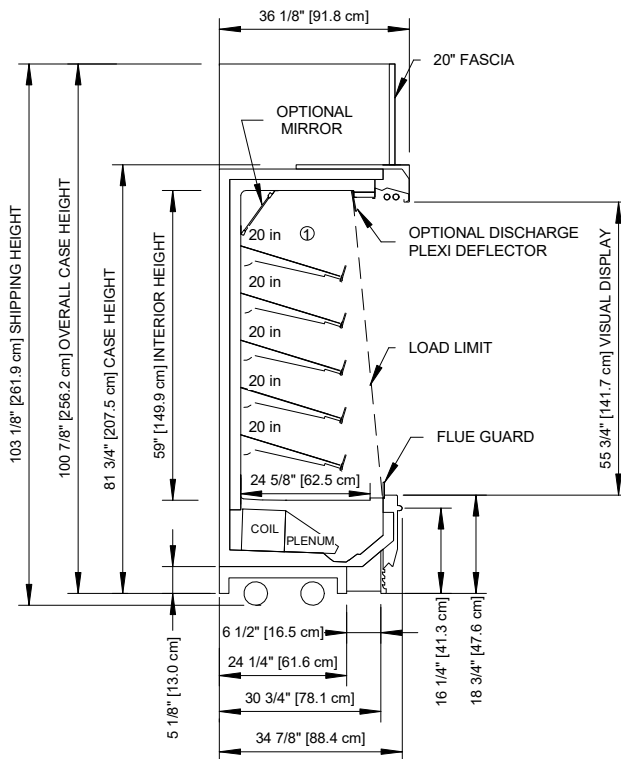

NOTES:

* : STUB-UP AREA

** : RECOMMENDED STUP-UP CENTERLINE FOR ELECTRICAL AND HUB DRAINS

Ⓛ : AVAILABLE SHELF SIZES: 20"

- Ends add approximately 1" to case height, 1/2" to the back of the case and 1" to the front of the case.
- A 12-inch minimum clearance is required above case fascia, presuming single case line-up. Consult the factory if multiple cases are being placed in the line-up.



COMPONENT
ALL MEASUREMENTS ARE TAKEN PER ASHRAE-72 SPECIFICATIONS. HILLPHOENIX REFRIGERATED DISPLAY CASES FOR SALE IN THE UNITED STATES MEET OR EXCEED DEPARTMENT OF ENERGY 2017 REQUIREMENTS.

ON5MXA-NRG

Rev. Date	Rev. #	Rev. Title
02-02-26	1	OPTIONS PAGE
12-03-25	0	R-290 CONVERSION



B1 WIRING DIAGRAM

CAD SYMBOLS		CAD SYMBOLS	
TAG	SYMBOL DESCRIPTION	SYMBOL	SYMBOL DESCRIPTION
CB	1 POLE CIRCUIT BREAKER		CB
CB	2 POLE CIRCUIT BREAKER		CB
TB	2 - CONDUCTOR THROUGH TERMINAL BLOCK		TB
TB	4 - CONDUCTOR THROUGH TERMINAL BLOCK		TB
R/CONT	RELAY/CONTACTOR COIL		R/CONT
R/CONT	RELAY/CONTACTOR NO OR NC CONTACT		R/CONT
R	FORM C RELAY CONTACT		R
SSR	SOLID STATE RELAY		SSR
GND	GROUND CONNECTION		GND
DA/DT	TEMPERATURE PROBE		DA/DT
HTR	HEATER		HTR
DRIVER / PWS	LED DRIVER / POWER SUPPLY		DRIVER / PWS
LIGHT	LED LIGHT		LIGHT
AEC	ANTHONY ENERGY CONTROLLER		AEC
LSW	LED SWITCH		LSW
TR	TRANSFORMER		TR

CAD SYMBOLS		CAD SYMBOLS	
TAG	SYMBOL DESCRIPTION	SYMBOL	SYMBOL DESCRIPTION
H1# / C#	PLUG CONNECTOR		PL
A1# / H3#	RECEPTACLE CONNECTOR		RECP
RECP	PUMP RECEPTACLE		RECP
FS	FLOAT SWITCH		FS
PS	HIGH PRESSURE SWITCH		PS
PS	LOW PRESSURE SWITCH		PS
SW	THERMODUCT-STAT		TAS
JUMPER	TERMINAL BLOCK SHORT LINK / JUMPER		JUMPER
CT	CURRENT TRANSFORMER		CT
PT	PRESSURE TRANSDUCER		PT
EF	EVAP FAN		EF
LS	LIQUID SOLENOID		LS
EEV	ELECTRONIC EXPANSION VALVE		EEV
###	WIRE NUMBER		###
FU	FUSE		FU

LOCATION: J-BOX
 REF: VI, MT, OT,
 OSDMAON5DMA288V
 MPX ZERO ADV CTLR WITHOUT
 CONNECTORS, R290.

DATE: 10-29-2024
 DRAWN BY: SRM

USE COPPER CONDUCTORS ONLY
 * TIGHTEN ALL ELECTRICAL CONNECTIONS
 * ALL WIRING MUST BE DONE IN
 ACCORDANCE WITH THE LOCAL AND OTHER
 LOCAL CODES.

TERMINAL BLOCK LAYOUT & COWIRING UPDATED
 PAN ITR WIRING UPDATED TO 288V
 PAN ITR WIRING UPDATED AND WIRE RUN LIST ADDED
 FOR INITIAL REVIEW AND RELEASE

REVISIONS

REV	DATE	REV BY	ECN	DESCRIPTION
3	04-22-2025	SHS	124234	TERMINAL BLOCK LAYOUT & COWIRING UPDATED
2	03-27-2025	SHS	124056	PAN ITR WIRING UPDATED TO 288V
1	02-24-2025	SHS	123786	PAN ITR WIRING UPDATED AND WIRE RUN LIST ADDED
0	10-29-2024	SRM	123350	FOR INITIAL REVIEW AND RELEASE

Checked By: MVC
 Drawing No: R807477
 File Name: R807477_PCS

USE IS PROHIBITED WITHOUT PERMISSION FROM HALPHENIX

Halphenix
 10000 Highway 100, Suite 100
 Dallas, TX 75243
 Phone: 972-412-1000
 Fax: 972-412-1001
 Email: sales@halphenix.com

USE IS PROHIBITED WITHOUT PERMISSION FROM HALPHENIX

DATE: 10-29-2024
 DRAWN BY: SRM

CHECKED BY: MVC
 DRAWING NO: R807477
 FILE NAME: R807477_PCS

USE IS PROHIBITED WITHOUT PERMISSION FROM HALPHENIX

B3 WIRING DIAGRAM

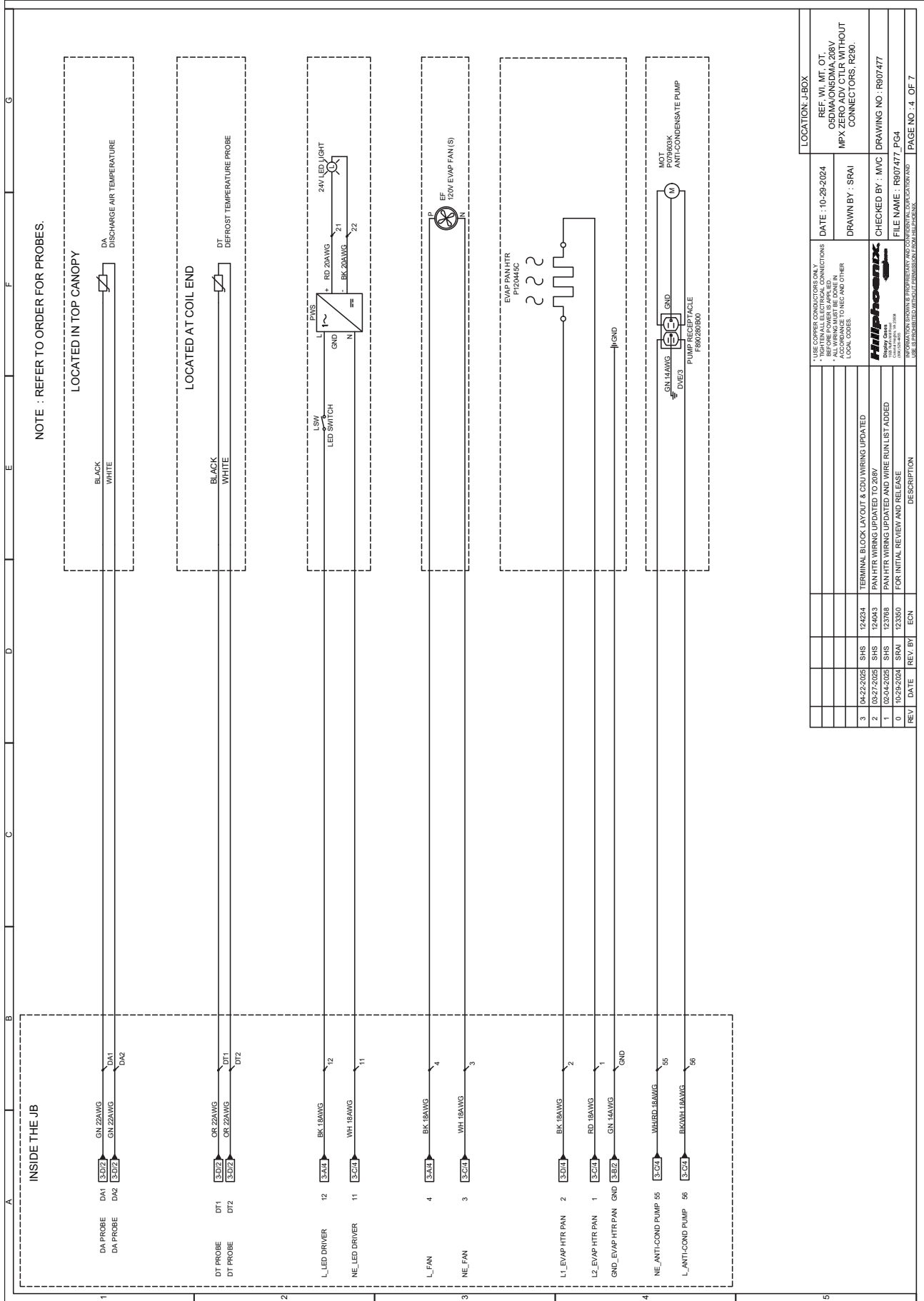

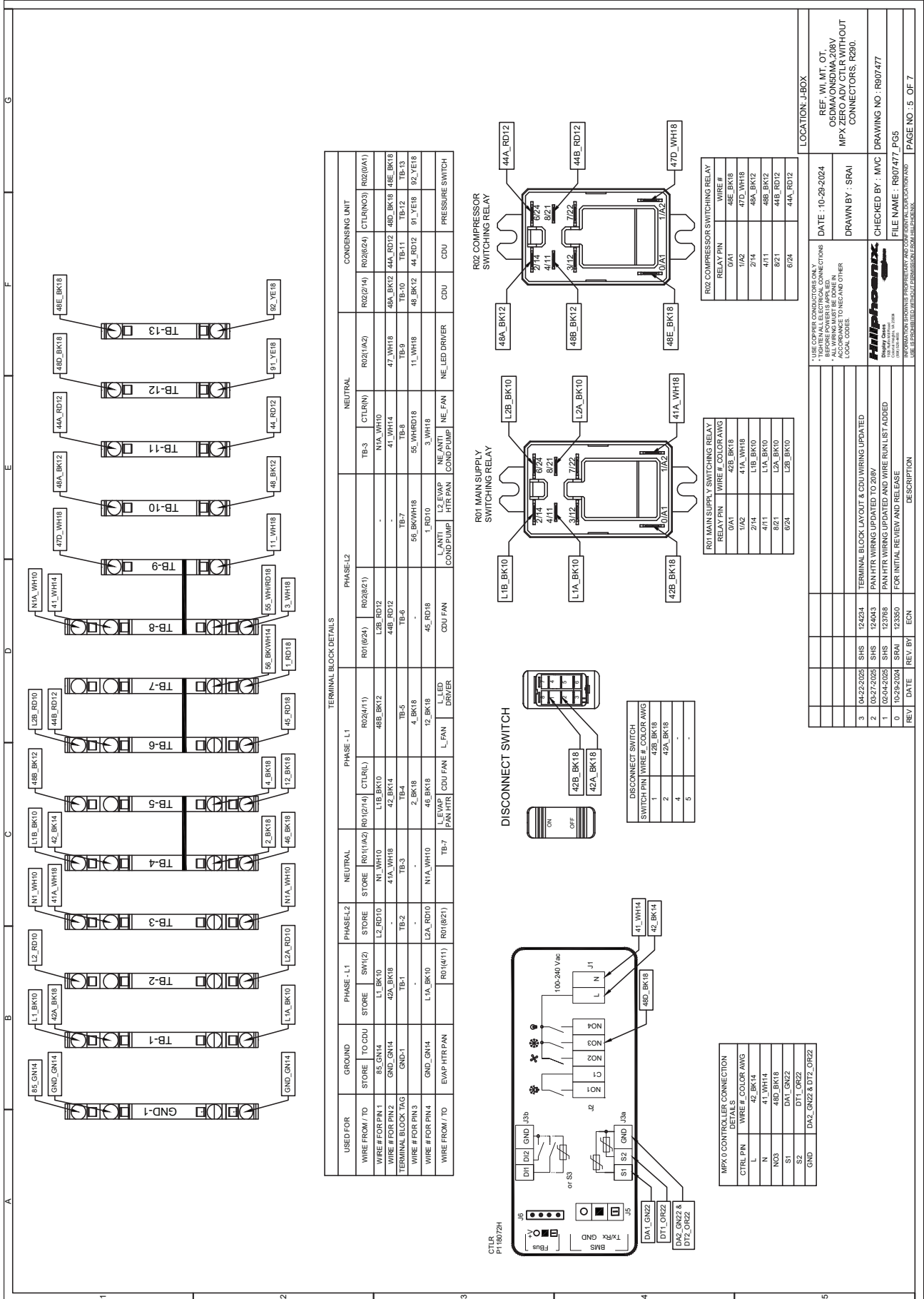

TERMINAL BLOCK DETAILS

USED FOR	GROUND	PHASE-L1	PHASE-L2	NEUTRAL	PHASE-L1	PHASE-L2	NEUTRAL	CONDENSING UNIT
WIRE FROM / TO	STORE TO CDU	SW1(2)	STORE	STORE	R01(1/A2)	R01(2/14)	CTLR(N)	R02(1/A2)
WIRE # FOR PIN 1	85_GN14	L1_BK10	L2_RD10	NT_WH10	R02M(11)	R02M(12)	N1A_WH10	R02(2/14)
WIRE # FOR PIN 2	GND_GN14	42A_BK18	42A_BK18	41A_WH18	48B_BK12	48B_BK12	41_WH14	48A_BK12
TERMINAL BLOCK TAG	GND-1	TB-1	TB-2	TB-3	TB-4	TB-5	TB-6	44A_RD12
WIRE # FOR PIN 3	GND_GN14	L1A_BK10	L2A_RD10	L2A_RD10	46_BK18	46_BK18	55_WHRD18	44A_RD12
WIRE # FOR PIN 4	GND_GN14	L1A_BK10	L2A_RD10	L2A_RD10	46_BK18	46_BK18	55_WHRD18	44A_RD12
WIRE FROM / TO	EVAP HTR FAN	R01(4/11)	R01(8/21)	R01(8/21)	L1A_WHT	L2A_WHT	NE_FAN	CDU
					L1A_WHT	L2A_WHT	NE_FAN	CDU
					L1A_WHT	L2A_WHT	NE_FAN	CDU

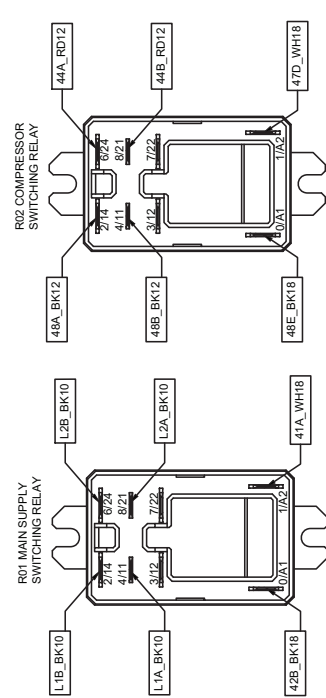

R01 MAIN SUPPLY SWITCHING RELAY

RELAY PIN	WIRE #	COLOR	AVG
0/A1	42B	BK18	
1/A2	41A	WH18	
2/14	48A	BK12	
4/11	L1A	BK10	
8/21	L2A	BK10	
0/A1	42B	BK18	

R02 COMPRESSOR SWITCHING RELAY

RELAY PIN	WIRE #	COLOR	AVG
0/A1	48E	BK18	
1/A2	47D	WH18	
2/14	48B	BK12	
4/11	48B	BK12	
8/21	44A	RD12	
0/A1	44A	RD12	

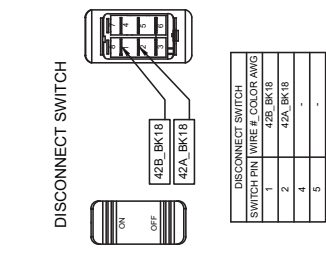

DISCONNECT SWITCH

SWITCH PIN	WIRE #	COLOR	AVG
1	42B	BK18	
2	42A	BK18	
4	-	-	-
5	-	-	-

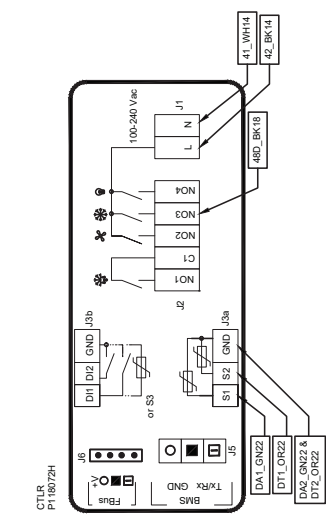

MPX0 CONTROLLER CONNECTION DETAILS

CTRL PIN	WIRE #	COLOR	AVG
L	42	BK14	
N	41	WH14	
NO3	48D	BK18	
S1	DA1	GN22	
S2	DT1	ORZ2	
GND	DA2	GN22 & DT2	ORZ2

REV	DATE	REV BY	ECN	DESCRIPTION
3	04-23-2025	SJS	12424	TERMINAL BLOCK LAYOUT & CDU WIRING UPDATED
2	02-27-2025	SJS	12403	FAN HTR WIRING UPDATED TO 20W
1	02-24-2025	SJS	12398	FAN HTR WIRING UPDATED AND WIRE RUN LIST ADDED
0	03-29-2024	SRM	12350	FOR INITIAL REVIEW AND RELEASE

DATE	10-29-2024
DRAWN BY	SRM
CHECKED BY	MVC
DRAWING NO	R007477
FILE NAME	R007477_PCS

LOCATION: J-BOX

REF: W1, MT, OT, 05DMAONSDMA, 208V MPX ZERO ADV CTLR WITHOUT CONNECTORS, R290.

DATE: 10-29-2024

DRAWN BY: SRM

CHECKED BY: MVC

DRAWING NO: R007477

FILE NAME: R007477_PCS

DATE: 10-29-2024

REV: 3

DATE: 04-23-2025

REV BY: SJS

ECN: 12424

DESCRIPTION: TERMINAL BLOCK LAYOUT & CDU WIRING UPDATED

* USE COPPER CONDUCTORS ONLY
 * TERMINAL ELECTRICAL CONNECTIONS
 * ALL WIRING MUST BE DONE IN ACCORDANCE WITH LOCAL AND OTHER LOCAL CODES

MPX0 CONTROLLER CONNECTION DETAILS

DATE: 10-29-2024

DRAWN BY: SRM

CHECKED BY: MVC

DRAWING NO: R007477

FILE NAME: R007477_PCS

DATE: 10-29-2024

REV: 3

DATE: 04-23-2025

REV BY: SJS

ECN: 12424

DESCRIPTION: TERMINAL BLOCK LAYOUT & CDU WIRING UPDATED

MPX0 CONTROLLER CONNECTION DETAILS

DATE: 10-29-2024

DRAWN BY: SRM

CHECKED BY: MVC

DRAWING NO: R007477

FILE NAME: R007477_PCS

DATE: 10-29-2024

REV: 3

DATE: 04-23-2025

REV BY: SJS

ECN: 12424

DESCRIPTION: TERMINAL BLOCK LAYOUT & CDU WIRING UPDATED

B5 WIRING DIAGRAM

SLNO	WIRE #	LENGTH	COLOR	AWG	WIRE P#	WIRE FROM	WIRE TO	STRIP LENGTH	STRIP LENGTH	REMARKS
R290, OSDMA/ONSDMA -- R907477										
INCOMER WIRES										
1	L1	18"	BLACK	10AWG	P001631A	STORE	TB-1	0.35"(9MM)	0.47"(12MM)	
2	L2						TB-2			
3	L1A					TB-1	R01(4/11)			
4	L2A					TB-2	R01(8/21)			
5	L1B	18"	BLACK	10AWG	P001631A	TB-4	R01(2/14)	0.35"(9MM) (YEL FLG-P042307K)		
6	L2B					TB-6	R01(6/24)			
7	N1		WHITE			TB-3	STORE	0.35"(9MM)		
8	N1A					TB-3	STORE	0.47"(12MM)		
9	85	142"(HARNES)	GREEN	14AWG	P002454G	GND-1	STORE	0.35"(9MM)		
CONTROLLER										
10	42	18"	BLACK	14AWG	P001548G	CTLR(L)	TB-1			
11	41	18"	WHITE	14AWG	P001547K	CTLR(N)	TB-8			
12	GND	20"	GREEN	14AWG	P002454G	CDU	GND-1	0.35"(9MM)	0.47"(12MM)	
13	GND	20"	GREEN	14AWG	P002454G	DOOR				
14	48D	10"	BLACK	18AWG	P001278A	CTLR(N03)	TB-12		0.47"(12MM)	
RELAYS										
15	47D		WHITE		P001277C	R02(L/A2)	TB-9			
16	41A					R01(L/A2)	TB-3	0.35"(9MM) (RED FLG-P096492E)	0.47"(12MM)	
17	48E	10"		18AWG		R02(O/A1)	TB-13			
18	42A		BLACK		P001278A	SW1(2)	TB-1	0.35"(9MM)		
19	42B					SW1(1)	R01(I/A2)		0.35"(9MM) (RED FLG-P096492E)	
20	44B					R02(B/21)	TB-6			
21	44A		RED		P001630C	R02(6/24)	TB-11	0.35"(9MM) (YEL FLG-P042307K)		
22	44					CDU	TB-11	0.35"(9MM)		
23	48B	18"	BLACK	12AWG	P001629E	R02(4/11)	TB-5		0.47"(12MM)	
24	48A					R02(2/14)	TB-10	0.35"(9MM) (YEL FLG-P042307K)		
25	48					CDU	TB-10			
26	45		RED	18AWG	P001415K	CDU FAN	TB-6	0.35"(9MM)		
27	46		BLACK		P001278A	CDU FAN	TB-4			

LOCATION: J-BOX	
DATE: 10-29-2024	CHECKED BY: MVC
DRAWN BY: SRAI	DRAWING NO: R907477
REF: WI, MT, OT, OSDMA/ONSDMA, 208V MPX ZERO ADV CTLR WITHOUT CONNECTORS, R290.	
FILE NAME: R907477_P06	
PAGE NO: 6 OF 7	

C1 CONTROLLERS & SETPOINTS

Parameter table

Code	Description	Def	Min	Max	UOM	User Terminal	DAIRY OSDMA
Analogue inputs							
PI	Type of probe, group 1 (S1, S2, S3) 0 = NTC Standard Range -50/100 °C 1 = NTC Standard Range -50/100 °C	1	0	1	-	S	YES
PE	Configuration of analogue output Y1: 0 = (0-10 V, 6 = PWM)	6	0	6	-	S	NO
PF	Configuration of analogue output Y2: 0 = (0-10 V, 6 = PWM)	6	0	6	-	S	NO
PA	0 = Function disabled -1 = Serial probe S11 -2 = Serial probe S12 -3 = Serial probe S13 -4 = Serial probe S14	1	-4	3	-	S	YES
PD	Assign defrost temperature probe (SD) - see IFA	2	-4	3	-	S	YES
PE	Assign intake temperature probe (SI) - see IFA	3	-4	3	-	S	YES
PF	Assign defrost temperature probe Z (SZ2) - see IFA	0	-4	3	-	S	NO
PG	Assign auxiliary temperature/pressure probe 1 (Suux1) - see IFA	0	-4	3	-	S	NO
PH	Assign auxiliary temperature/pressure probe 2 (Suux2) - see IFA	0	-4	3	-	S	NO
PI	Assign ambient temperature probe (SA) - see IFA	0	-4	3	-	S	NO
PJ	Assign ambient humidity probe (SU) - see IFA	0	-4	3	-	S	NO
PK	Assign glass temperature probe (SV1) - see IFA	0	-4	3	-	S	NO
PL	Assign glass temperature probe (SV2) - see IFA	0	-4	3	-	S	NO
PM	Assign dewpoint value (SDP) - see IFA	0	-20	20	°C/F	S	NO
PN	Intake temperature probe (SI) calibration	0	-20	20	°C/F	S	NO
PO	Defrost temperature probe Z (SZ2) calibration	0	-20	20	°C/F	S	NO
PP	Auxiliary temperature/pressure probe 1 (Suux1) calibration	0	-20	20	°C/F	S	NO
PQ	Auxiliary temperature/pressure probe 2 (Suux2) calibration	0	-20	20	°C/F	S	NO
PR	Ambient temperature probe (SA) calibration	0	-20	20	°C/F	S	NO
PS	Ambient humidity probe (SU) calibration	0	-20	20	°C/F	S	NO
PT	Class temperature probe (SV) calibration	0	-20	20	°C/F	S	NO
PV	Dewpoint value (SDP) calibration	0	-20	20	°C/F	M	NO
PW	Condenser temperature probe calibration	0	-20	20	°C/F	M	NO
PX	Analogue probe measurement stability	9	1	15	-	M	NO

Code	Description	Def	Min	Max	UOM	User Terminal	DAIRY OSDMA
Control							
ON	ON/OFF command 0 = OFF, 1 = ON	0	0	1	-	S	YES
/4	Virtual probe composition 0 = Air off probe Sn 1 = Air on probe Sn	0	0	100	%	S	NO
11	Minimum set point	50	50	15	°C/F	M	18
12	Maximum set point	50	11	200	°C/F	M	65
13	Automatic night set point variation	0	-50	50	°C/F	S	NO
14	Probe for night-time control	0	0	1	-	S	NO
r6	01 = virtual probe Sv, 1 = intake probe Sr	0	0	20	°C/F	S	NO
r7	Control offset with probe error	0	0	1	-	S	YES
SI	Master solenoid valve configuration	50	r1	r2	°C/F	U	32
SIZ	Intake probe set point with double thermostat	50	r1	r2	°C/F	S	NO
rd	Differential	2	0.1	99.9	°C/F	U	2
rc	Operating mode 0 = Direct, 1 = Reverse	0	0	1	-	U	NO
r22	Set point SIZ differential with double thermostat 0 = function disabled	0	0	99.9	°C/F	S	NO
rHS	Set point for glass temp. probe estimate 0 = Air off probe Sn 100 = Air on probe Sr	20	0	100	%	S	NO
rHA	Coeff. A for glass temp. probe estimate	2	-20	20	°C/F	S	NO
rHB	Coeff. B for glass temp. probe estimate	22	0	100	-	S	NO
rHO	Offset for anti-sweat modulation	2	-20	20	°C/F	S	NO
rHD	Differential for anti-sweat heater modulation	0	0	20	°C/F	S	NO
rHU	Manual anti-sweat heater activation percentage (of period 'rH') 0 = function disabled	70	0	100	%	S	NO
rHI	Manual anti-sweat heater activation period 0 = function disabled	5	0	180	min	S	NO
GLI	Max. time for Clean status	0	0	999	min	U	NO
SII	Maximum time for Standby status	0	0	240	min	U	NO
H14	Time light stays on after closing the door	0	0	240	min	U	NO
dB5	Safety timeout for double thermostat function	0	0	240	min	M	NO
db1	Double thermostat function logic 0 = AND logic, 1 = OR logic	0	0	1	-	M	NO

Code	Description	Def	Min	Max	UOM	User Terminal	DAIRY OSDMA
Digital outputs							
DOA	Assign solenoid/compressor digital output 0 = not configured 1 = digital input 1 (ID3) 2 = digital output 1 (ID2) 3 = digital input 3 (ID3) 4 = digital input 4 (ID4)	2	0	4	-	S	NO
DOB	Assign alarm digital output - see DOA	0	0	4	-	S	NO
DOE	Assign auxiliary digital output serving the Main on the Secondary devices - see DOA	0	0	4	-	S	NO
DOF	Assign light digital output serving the Main on the Secondary devices - see DOA	4	0	4	-	S	NO
DOG	Assign auxiliary evaporator defrost digital output - see DOA	1	0	4	-	S	NO
DOH	Assign auxiliary evaporator defrost digital output - see DOA	0	0	4	-	S	NO
DOI	Assign second ON/OFF compressor digital output - see DOA	0	0	4	-	S	NO
DOJ	Assign evaporator fan digital output - see DOA	3	0	4	-	M	NO
DOK	Assign evaporator fan digital output (pump down)	0	0	4	-	S	NO
DOP	Assign drain heater digital output - see DOA	0	0	4	-	M	NO
DOQ	Assign anti-sweat heater digital output - see DOA	0	0	4	-	S	NO
DOAA	Assign hot gas defrost digital output - see DOA	0	0	4	-	M	NO
DOU	Assign digital output for min fan speed connection	0	0	4	-	M	NO
ROA	Assign digital output for max fan speed connection	0	0	4	-	M	NO
ROB	Speed/compressor digital output logic 0 = direct, 1 = reverse	0	0	1	-	M	NO
ROD	Alarm digital output logic - see ROA	0	0	1	-	M	NO
ROE	Auxiliary digital output logic - see ROA	0	0	1	-	M	NO
ROF	Light digital output logic - see ROA	0	0	1	-	S	NO
ROG	Defrost digital output logic - see ROA	0	0	1	-	S	NO
ROI	Auxiliary evaporator defrost digital output logic - see ROA	0	0	1	-	S	NO
ROJ	Evaporator fan digital output logic - see ROA	0	0	1	-	M	NO
ROK	Drain heater digital output logic - see ROA	0	0	1	-	M	NO
ROL	Anti-sweat heater digital output logic - see ROA	0	0	1	-	M	NO
ROM	Hot gas defrost digital output logic - see ROA	0	0	1	-	M	NO
ROU	Minimum fan speed connection digital output logic - see ROA	0	0	1	-	M	NO
ROV	Maximum fan speed connection digital output logic - see ROA	0	0	1	-	M	NO
ROW	Output switched with time bands	0	0	1	-	S	NO
ROX	0 = Light 1 = ALIX	-	-	-	-	-	-
ROY	Relay Type	-	-	-	-	-	-
ROZ	0 = normal mode 1 = delayed mode 2 = zero crossing	-	-	-	-	-	-
RO14	0 = normal mode 1 = delayed mode 2 = zero crossing	-	-	-	-	-	-
Digital inputs							
DIC	Assign start defrost digital input - see DIA	0	-1	2	-	S	NO

Note:
For full parameter list and instructions, please refer to Carel's website
<https://www.carel.com/documents/101910/%2B0300106EN/aa0a54c-0dec-45b4-92b4-bc812dfc3fa?version=1.0>

ALL BENDS 90° UNLESS SPECIFIED
UNITS = INCHES (MM)
TOLERANCES UNLESS SPECIFIED
DIMENSIONS ON FLAT UNLESS NOTED
DIMENSIONS ON RADIUS UNLESS NOTED
DIMENSIONS NOT TO SCALE



Display Case
R908478
DATE: 02/07/25
E.CN INO/RZ
DESCRIPTION
RELEASED TO PRODUCTION
1 PARAMETERS UPDATED
124441
123763
06/09/25
SHS

SETPOINTS, MPXzero
O5DMA/ON5DMA
208V, R290

C3 CONTROLLERS & SETPOINTS

Code	Description	Def	Min	Max	UOM	User Terminal	DAIRY OSDMA
Solenoid/compressor							
c0	Delay to enable solenoid/compressor and evaporation fans at power-on	0	0	240	min	M	NO
c1	Minimum time between consecutive compressor starts	0	0	15	min	M	NO
c2	Minimum compressor OFF time	0	0	15	min	M	NO
c3	Minimum compressor ON time	0	0	15	min	M	NO
c4	ON time for duty setting operation (Tdiff = 15 minutes, fixed value) 0 = compressor/valve always OFF 100 = compressor/valve always ON	0	0	100	min	M	NO
cc	Running time in continuous cycle 0 = Disabled	1	0	15	hours	M	NO
c6	Low temperature alarm bypass time after continuous cycle	60	0	240	min	M	NO
c11	Second compressor start delay	4	0	250	s	S	NO
c12	Second compressor start mode 0 = delay at start and in normal control 1 = delay sta start only	0	0	1	-	S	NO
Alarms							
A0	High and low temp alarm reset differential	2	0.1	20	°C/F	S	YES
A1	Alarm thresholds (AL1, AH1) relative to the set point S1 or absolute 0 = relative absolute	0	0	1	-	S	NO
A2	Alarm thresholds (AL2, AH2) relative to the set point S2 or absolute 0 = relative absolute	0	0	1	-	S	NO
A6	Configure compressor operation during external alarm (immediate or delayed) with fixed 15 min OFF time 0 = always OFF 100 = always ON	0	0	100	min	S	NO
A10	Configure solenoid/compressor control during external alarm (immediate or delayed) with fixed 15 min OFF time 0 = always ON 100 = always OFF	0	0	100	min	S	NO
A11	Delay time for delayed external alarm 0 = Signal-only alarm	0	0	240	min	S	NO
AA	Assign probe for high (AH/AHA) and low (AL/ALA) temperature alarms 0 = Not configured 1 = Outlet (Sn) 2 = Defrost (Sd) 3 = Intake (Si) 4 = Defrost 2 (Sd2) 5 = Ambient (Sa) 6 = Auxiliary 2 (Stat2) 7 = Ambient (SA) 8 = Reserved 9 = Glass temperature (Sv) 10 = Dewpoint (SdP) 11 = Virtual probe (Sv)	1	0	11	-	S	YES
AA2	Assign probe for high (AH2/AHA2) and low (AL2/ALA2) temperature alarms - see AA	1	0	11	-	S	NO
AL	Low temperature alarm threshold (relative to set point)	4	0	50	°C/F	S	YES
ALA	Low temperature alarm threshold (absolute threshold)	0	-50	50	°C/F	S	NO
AH	High temperature alarm threshold (relative to set point)	10	0	50	°C/F	S	YES
AHA	High temperature alarm threshold (absolute threshold)	0	-50	200	°C/F	S	NO
AL2	Low temperature alarm threshold 2	0	0	50	°C/F	S	NO
ALA2	Low temperature alarm threshold 2 (absolute threshold)	0	-50	50	°C/F	S	NO
AH2	High temperature alarm threshold 2	0	0	50	°C/F	S	NO
AHA2	High temperature alarm threshold 2 (absolute threshold)	0	-50	200	°C/F	S	NO
AA	Delay time for high and low temperature alarms (AH/AHA, AL/ALA)	120	0	240	min	U	YES
AA2	Delay time for high and low temp. alarms (AH2/AHA2, AL2/ALA2)	30	1	240	min	U	NO
Ar	Signal alarms from Secondary to Main 0 = not enabled, 1 = enabled	1	0	1	-	S	NO
A3d	High temperature alarm bypass time for door open	30	1	240	min	U	NO
Tdoor	Door open alarm delay	30	1	240	min	S	NO
Htd	HACCP alarm delay 0 = monitoring disabled	0	0	240	min	S	NO
Notice: * for alarms with an absolute activation threshold (A=1) the thresholds ALA/ALA2 and AHA/AHA2 need to be set correctly (default full scale, absolute alarms disabled).							

Code	Description	Def	Min	Max	UOM	User Terminal	DAIRY OSDMA
Connectivity							
In	Type of unit 0 = Secondary, 1 = Main	0	0	1	-	S	YES
H0	Serial or Main/Secondary network address	199	0	247	-	S	YES
H1	BMS serial port configuration (stop bits and parity) 0 = 1 stop bit, no parity 1 = 2 stop bit, no parity 2 = 1 stop bit, odd parity 3 = 2 stop bits, even parity 4 = 1 stop bit, odd parity 5 = 2 stop bits, odd parity	1	0	5	-	S	YES
H2	BMS serial port baudrate (bits) 0 = 1200 1 = 2400 2 = 4800 3 = 9600 4 = 19200 5 = 38400 6 = 57600 7 = 115200	4	0	8	-	S	YES
H3	BMS serial port protocol 0 = Cabel, 1 = Modbus	1	0	1	-	S	YES
Fieldbus							
Sn	No. of slaves in the local network 0 = no Slaves	0	0	9	-	S	NO
H4	Bus port baudrate (bits) 0 = 1200 1 = 2400 2 = 4800 3 = 9600 4 = 19200 5 = 38400 6 = 57600 7 = 115200	4	0	1	-	S	NO
Notice: on fixed DEFAULT values for VCC serial							
Display							
/5	Unit of measure 0 = °C/barg, 1 = °F/psig	0	0	1	-	S	YES
/6	Display decimal point 0 = Yes, 1 = No	0	0	1	-	S	NO
/11	Display on user terminal 0 = Terminal disabled 1 to 3 = Probe 1 to 3 4 to 8 = Reserved 9 = Control probe 10 = Virtual probe 11 to 14 = Serial Probe 1 to 4 15 = Temperature set point	9	0	15	-	S	NO
H5	Enable keypad and NFC functions 0 = Disabled, 1 = Enabled	1	0	1	-	U	NO
H8	8x20 0 = No, 1 = Yes	1	0	1	-	U	NO
ON	Unit On/Off command on display	1	0	1	-	S	NO
ONK	Enable unit On/Off from display	1	0	1	-	S	NO
ONS	Enable unit On/Off from supervisor	0	0	1	-	S	NO
Day/Night							
Is1..8-d	Start time band 1 to 8 day/day - see (d1..8-d)	0	0	11	day	S	NO
Is1..8-h	Start time band 1 to 8 day: hours	0	0	23	hours	S	NO
Is1..8-mm	Start time band 1 to 8 day: minutes	0	0	59	minutes	S	NO
IE1..8-d	End time band 1 to 8 day/day - see (d1..8-d)	0	0	11	day	S	NO
IE1..8-h	End time band 1 to 8 day: hours	0	0	23	hours	S	NO
IE1..8-mm	End time band 1 to 8 day: minutes	0	0	59	minutes	S	NO
ALL BANDS 90° UNLESS SPECIFIED							
UNITS = INCHES (MM)							
TOLERANCES UNLESS SPECIFIED							
DIMENSIONS ON FLAT VIEWS ±0.10							
DIMENSIONS ON ROUND VIEWS ±0.03							
DRAWING NOT TO SCALE							
Hilphoenix							
Display Case							
Control Panel V1.31.34							
Hilphoenix is a registered trademark of Hilphoenix, an indirect or direct subsidiary of the Hilphoenix Group.							
REV. 02/09/25 124441 1 PARAMETERS UPDATED							
REV. 02/09/25 123763 X RELEASED TO PRODUCTION							
BY	DATE	ECN	NO./R	DESCRIPTION			

SETPOINTS, MPXzero
O5DMA/ON5DMA
208V, R290

R908478

C5 CONTROLLERS & SETPOINTS

Parameter table

Code	Description	Def	Min	Max	UOM	User Terminal	DELI OSDMA
Analogue inputs							
FP1	Type of probe, group 1 (S1, S2, S3) 0 = NTC Standard Range -50/100 °C 1 = NTC Standard Range -50/30 °C	1	0	1	-	S	YES
FP5	Configuration of analogue output Y2: 0 = (0-10 V, 6 = PWM)	6	0	6	-	S	NO
FP6	Configuration of analogue output Y2: 0 = (0-10 V, 6 = PWM)	6	0	6	-	S	NO
FA	0 = Function disabled -1 = Serial probe S11 -2 = Serial probe S12 -3 = Serial probe S13 -4 = Serial probe S14	1	-4	3	-	S	YES
FB	Assign defrost temperature probe (SD) - see IFA	2	-4	3	-	S	YES
FC	Assign intake temperature probe (SI) - see IFA	3	-4	3	-	S	YES
FD	Assign auxiliary temperature/pressure probe 1 (Suux1) - see IFA	0	-4	3	-	S	NO
FE	Assign auxiliary temperature/pressure probe 2 (Suux2) - see IFA	0	-4	3	-	S	NO
FF	Assign ambient temperature probe (SA) - see IFA	0	-4	3	-	S	NO
FG	Assign ambient humidity probe (SU) - see IFA	0	-4	3	-	S	NO
FH	Assign glass temperature probe (SV1) - see IFA	0	-4	3	-	S	NO
FI	Assign glass temperature probe (SV2) - see IFA	0	-4	3	-	S	NO
FJ	Assign dewpoint value (SDP) - see IFA	0	-4	3	-	S	NO
FK	Outlet temperature probe (Sm) calibration	0	-20	20	°C/F	S	NO
FL	Intake temperature probe (SI) calibration	0	-20	20	°C/F	S	NO
FM	Defrost temperature probe 2 (SD2) calibration	0	-20	20	°C/F	S	NO
FN	Auxiliary temperature/pressure probe 1 (Suux1) calibration	0	-20	20	°C/F	S	NO
FO	Auxiliary temperature/pressure probe 2 (Suux2) calibration	0	-20	20	°C/F	S	NO
FP	Ambient temperature probe (SA) calibration	0	-20	20	°C/F	S	NO
FQ	Ambient humidity probe (SU) calibration	0	-20	20	°C/F	S	NO
FR	Glass temperature probe (SV) calibration	0	-20	20	°C/F	S	NO
FS	Dewpoint value (SDP) calibration	0	-20	20	°C/F	S	NO
FT	Condenser temperature probe calibration	0	-20	20	°C/F	M	NO
FU	Analogue probe measurement stability	9	1	15	-	M	NO

Code	Description	Def	Min	Max	UOM	User Terminal	DELI OSDMA
Control							
ON	ON/OFF command 0 = OFF, 1 = ON	0	0	1	-	S	YES
/4	Virtual probe composition 0 = Air off probe Sln 1 = Air on probe Sln	0	0	100	%	S	NO
11	Minimum set point	50	50	100	°C/F	M	NO
12	Maximum set point	50	11	200	°C/F	M	NO
13	Automatic night set point variation	0	-50	50	°C/F	M	NO
14	Probe for night-time control	0	0	1	-	S	NO
r6	01 = virtual probe Sv, 1 = intake probe Sr	0	0	20	°C/F	S	NO
r7	Control offset with probe error	0	0	1	-	S	YES
SI	Master solenoid valve configuration 0 = local valve, 1 = network valve (connected to Main)	50	r1	r2	°C/F	U	YES
SIZ	Set point	50	r1	r2	°C/F	U	YES
rd	Intake probe set point with double thermostat	2	0.1	99.9	°C/F	U	YES
rc	Differential	0	0	1	-	U	NO
r2	Operating mode 0 = Direct, 1 = Reverse	0	0	99.9	°C/F	S	NO
rHS	Set point SIZ differential with double thermostat 0 = function disabled 100 = Air on probe Sln	20	0	100	%	S	NO
rHA	Coeff. A for glass temp. probe estimate	2	-20	20	°C/F	S	NO
rHB	Coeff. B for glass temp. probe estimate	22	0	100	-	S	NO
rHO	Offset for anti-sweat modulation	2	-20	20	°C/F	S	NO
rHD	Differential for anti-sweat heater modulation	0	0	20	°C/F	S	NO
rHU	Manual anti-sweat heater activation percentage (of period 'rH') 0 = function disabled 100 = function enabled	70	0	100	%	S	NO
rHI	Manual anti-sweat heater activation period 0 = function disabled	5	0	180	min	S	NO
GLI	Max. time for Clean status	0	0	999	min	U	NO
Slt	Maximum time for Standby status	0	0	240	min	U	NO
H14	Time light stays on after closing the door	0	0	240	min	U	NO
dB5	Safety timeout for double thermostat function	0	0	240	min	M	NO
db1	Double thermostat function logic 0 = AND logic, 1 = OR logic	0	0	1	-	M	NO

Code	Description	Def	Min	Max	UOM	User Terminal	DELI OSDMA
Digital outputs							
DOA	Assign solenoid/compressor digital output 0 = not configured 1 = digital output 1 (DO1) 2 = digital output 2 (DO2) 3 = digital input 3 (ID3) 4 = digital input 4 (ID4)	2	0	4	-	S	NO
DOB	Assign alarm digital output - see DOA	0	0	4	-	S	NO
DOE	Assign auxiliary digital output serving the Main on the Secondary devices - see DOA	0	0	4	-	S	NO
DOF	Assign light digital output serving the Main on the Secondary devices - see DOA	4	0	4	-	S	NO
DOG	Assign auxiliary evaporator defrost digital output - see DOA	1	0	4	-	S	NO
DOH	Assign second ON/OFF compressor digital output - see DOA	0	0	4	-	S	NO
DOI	Assign evaporator fan digital output - see DOA	3	0	4	-	M	NO
DOJ	Assign evaporator fan digital output (pump down)	0	0	4	-	S	NO
DOK	Assign drain heater digital output - see DOA	0	0	4	-	M	NO
DOO	Assign anti-sweat heater digital output - see DOA	0	0	4	-	S	NO
DOQ	Assign hot gas defrost digital output - see DOA	0	0	4	-	M	NO
DOA	Assign digital output for min fan speed connection	0	0	4	-	M	NO
DOU	Assign digital output for max fan speed connection	0	0	4	-	M	NO
ROA	Stenooid/compressor digital output logic 0 = direct, 1 = reverse	0	0	1	-	M	NO
ROB	Alarm digital output logic - see ROA	0	0	1	-	M	NO
ROE	Auxiliary digital output logic - see ROA	0	0	1	-	M	NO
ROF	Light digital output logic - see ROA	0	0	1	-	S	NO
ROG	Defrost digital output logic - see ROA	0	0	1	-	S	NO
ROH	Auxiliary evaporator defrost digital output logic - see ROA	0	0	1	-	S	NO
ROI	Evaporator fan digital output logic - see ROA	0	0	1	-	M	NO
ROJ	Drain heater digital output logic - see ROA	0	0	1	-	M	NO
ROK	Anti-sweat heater digital output logic - see ROA	0	0	1	-	M	NO
ROO	Hot gas defrost digital output logic - see ROA	0	0	1	-	M	NO
ROQ	Minimum fan speed connection digital output logic - see ROA	0	0	1	-	M	NO
ROU	Output switched with time bands	0	0	1	-	M	NO
ROV	0 = Light 1 = ALX	0	0	1	-	S	NO
DOT1	Relay Type	-	-	-	-	-	-
DOT2	0: normal mode 2: cycled mode	-	-	-	-	-	-
DOT3	0: normal mode 1: delayed mode 3: zero crossing	-	-	-	-	-	-
DOT4	0: normal mode 1: delayed mode 3: zero crossing	-	-	-	-	-	-
Digital inputs							
DIC	Assign start defrost digital input - see DIA	0	-1	2	-	S	NO

Note:
For full parameter list and instructions, please refer to Carel's website
<https://www.carel.com/documents/101910/2B0300106EN/aa0a54c-0dec-45b4-92b4-bc812dfc3fa?version=1.0>

ALL BENDS 90° UNLESS SPECIFIED
UNITS = INCHES (MM)
TOLERANCES UNLESS SPECIFIED
DIMENSIONS ON FLAT VIEWS ±0.10
DIMENSIONS ON ROUND VIEWS ±0.03
DIMENSIONS NOT TO SCALE

Hilphoenix
Display Case
Carel Italia S.p.A.
Via S. Maria 10, 38100 Trento, Italy
Tel: +39 0461 234111
Fax: +39 0461 234112
E-mail: hilphoenix@carel.com

SHS 06/09/25 124441 1 PARAMETERS UPDATED
REV. 04/04/25 124123 X RELEASED TO PRODUCTION
BY DATE IECN NO./R/ DESCRIPTION
DRAWN BY: SIS DATE: 04/04/25

SETPOINTS, MPXzero
O5DMA/ON5DMA DELI
208V, R290

R909346

C7 CONTROLLERS & SETPOINTS

Code	Description	Def	Min	Max	UOM	User Terminal	DELI OSDMA
Solenoid/compressor							
c0	Delay to enable solenoid/compressor and evaporation fans at power-on	0	0	240	min	M	NO
c1	Minimum time between consecutive compressor starts	0	0	15	min	M	NO
c2	Minimum compressor OFF time	0	0	15	min	M	NO
c3	Minimum compressor ON time	0	0	15	min	M	NO
c4	ON time for duty setting operation (Tdiff = 15 minutes, fixed value) 0 = compressor/valve always OFF 100 = compressor/valve always ON	0	0	100	min	M	NO
cc	Running time in continuous cycle 0 = Disabled	1	0	15	hours	M	NO
c6	Low temperature alarm bypass time after continuous cycle	60	0	240	min	M	NO
c11	Second compressor start delay	4	0	250	s	S	NO
c12	Second compressor start mode 0 = delay at start and in normal control 1 = delay sta start only	0	0	1	-	S	NO
Alarms							
A0	High and low temp alarm reset differential	2	0.1	20	°C/F	S	YES
A1	Alarm thresholds (AL1, AH1) relative to the set point S1 or absolute 01 = relative absolute	0	0	1	-	S	NO
A2	Alarm thresholds (AL2, AH2) relative to the set point S2 or absolute 01 = relative absolute	0	0	1	-	S	NO
A6	Configure compressor operation during external alarm (immediate or delayed) with fixed 15 min OFF time 0 = always OFF 100 = always ON	0	0	100	min	S	NO
A10	Configure solenoid/compressor control during external alarm (immediate or delayed) with fixed 15 min OFF time 01 = always ON 100 = always OFF	0	0	100	min	S	NO
A11	Delay time for delayed external alarm 0 = Signal-only alarm	0	0	240	min	S	NO
AA	Assign probe for high (AH/AHA) and low (AL/ALA) temperature alarms 0 = Not configured 1 = Outlet (Sn) 2 = Defrost (Sd) 3 = Intake (Si) 4 = Defrost 2 (Sd2) 5 = Ambient (Sa) 6 = Auxiliary 2 (Stat2) 7 = Ambient (Sa) 8 = Reserved 9 = Glass temperature (Sv) 10 = Dewpoint (SdP) 11 = Virtual probe (Sv)	1	0	11	-	S	YES
AA2	Assign probe for high (AH2, AH2) and low (AL2, AL2) temperature alarms - see AA	1	0	11	-	S	NO
AL	Low temperature alarm threshold (relative to set point)	4	0	50	°C/F	S	YES
ALA	Low temperature alarm threshold (absolute threshold)	0	-50	50	°C/F	S	NO
AH	High temperature alarm threshold (relative to set point)	10	0	50	°C/F	S	YES
AHA	High temperature alarm threshold (absolute threshold)	0	-50	200	°C/F	S	NO
AL2	Low temperature alarm threshold 2	0	0	50	°C/F	S	NO
ALA2	Low temperature alarm threshold 2 (absolute threshold)	0	-50	50	°C/F	S	NO
AH2	High temperature alarm threshold 2	0	0	50	°C/F	S	NO
AHA2	High temperature alarm threshold 2 (absolute threshold)	0	-50	200	°C/F	S	NO
AL	Delay time for high and low temperature alarms (AH/AHA, AL/ALA)	120	0	240	min	U	YES
A2	Delay time for high and low temp. alarms (AH2/AH2, AL2/AL2)	30	1	240	min	U	YES
Ar	Signal alarms from Secondary to Main 0 = not enabled, 1 = enabled	1	0	1	-	S	NO
A3d	High temperature alarm bypass time for door open	30	1	240	min	U	NO
Tdoor	Door open: alarm delay	30	1	240	min	S	NO
Htd	HACCP alarm delay 0 = monitoring disabled	0	0	240	min	S	NO

Notice: * for alarms with an absolute activation threshold (A=1) the thresholds ALA/ALA2 and AHA/AHA2 need to be set correctly (default full scale, absolute alarms disabled).

Code	Description	Def	Min	Max	UOM	User Terminal	DELI OSDMA
Connectivity							
In	Type of unit 0 = Secondary, 1 = Main	0	0	1	-	S	YES
H0	Serial or Main/Secondary network address	199	0	247	-	S	YES
H1	BMS serial port configuration (stop bits and parity) 0 = 1 stop bit, no parity 1 = 2 stop bit, odd parity 2 = 1 stop bit, even parity 3 = 2 stop bits, odd parity 4 = 1 stop bit, odd parity 5 = 2 stop bits, odd parity	1	0	5	-	S	YES
H2	BMS serial port baudrate (bits) 0 = 1200 1 = 2400 2 = 4800 3 = 9600 4 = 19200 5 = 38400 6 = 57600 7 = 115200	4	0	8	-	S	YES
H3	BMS serial port protocol 0 = Cabel, 1 = Modbus	1	0	1	-	S	YES

Code	Description	Def	Min	Max	UOM	User Terminal	DELI OSDMA
Fieldbus							
Sn	No. of slaves in the local network 0 = no Slaves	0	0	9	-	S	NO
H4	BUS port baudrate (bits) 0 = 1200 1 = 2400 2 = 4800 3 = 9600 4 = 19200 5 = 38400 6 = 57600 7 = 115200	4	0	1	-	S	NO

Notice: on fixed DEFAULT values for VCC serial

Code	Description	Def	Min	Max	UOM	User Terminal	DELI OSDMA
Display							
/S	Unit of measure 0 = °C/deg, 1 = °F/psig	0	0	1	-	S	YES
/B	Display decimal point 0 = Yes, 1 = No	0	0	1	-	S	NO
/I1	Display on user terminal 0 = Terminal disabled 1 to 3 = Probe 1 to 3 4 to 8 = Reserved 9 = Control probe 10 = Virtual probe 11 to 14 = Serial Probe 1 to 4 15 = Temperature set point	9	0	15	-	S	NO
H5	Enable keypad and NFC functions 0 = Disabled, 1 = Enabled	1	0	1	-	U	NO
H8	Buzzer 0 = No 1 = Yes	1	0	1	-	U	NO
ON	Unit On/Off command on display Enable unit On/Off from display	1	0	1	-	S	NO
ONS	Enable unit On/Off from supervisor	1	0	1	-	S	NO

Code	Description	Def	Min	Max	UOM	User Terminal	DELI OSDMA
Day/Night							
IE1..8-d	Start time band 1 to 8 day/day - see (d1..8-d)	0	0	11	day	S	NO
IE1..8-h	Start time band 1 to 8 day: hours	0	0	23	hours	S	NO
IE1..8-mm	Start time band 1 to 8 day: minutes	0	0	59	minutes	S	NO
IE1..8-d	End time band 1 to 8 day/day - see (d1..8-d)	0	0	11	day	S	NO
IE1..8-h	End time band 1 to 8 day: hours	0	0	23	hours	S	NO
IE1..8-mm	End time band 1 to 8 day: minutes	0	0	59	minutes	S	NO

Code	Description	Def	Min	Max	UOM	User Terminal	DELI OSDMA
SETPOINTS, MPXzero							
O5DMA/ON5DMA DELI							
208V, R290							
ALL BENDS 90° UNLESS SPECIFIED UNITS = INCHES (MM) TOLERANCES UNLESS SPECIFIED DIMENSIONS ON PLAN VIEWS ±0.10 DIMENSIONS ON ELEVATION VIEWS ±0.03 DIMENSIONS NOT TO SCALE Hilphoenix Display Case 124441 1 PARAMETERS UPDATED 06/09/25 124123 X RELEASED TO PRODUCTION 06/09/25 124123 X DRAWN BY: SHS DATE: 04/04/25							
SHS 06/09/25 124441 1 PARAMETERS UPDATED							R909346
REV. 04/04/25 124123 X RELEASED TO PRODUCTION							
BY	DATE	ECN NO./R	DESCRIPTION				

CONSTRAINT BRACKET INSTALLATION



The case constraint brackets can be installed in 2 ways. Option 1 can be used on multi-deck cases and uses an "L" bracket to attach the case to a vertical wall, as shown below. Option 2 can be used on multi-deck cases or on cases that do not have a canopy. Attach the "L" brackets to the base frames in either of the locations shown below. Brackets are available for all base frame heights.

OPTION 1

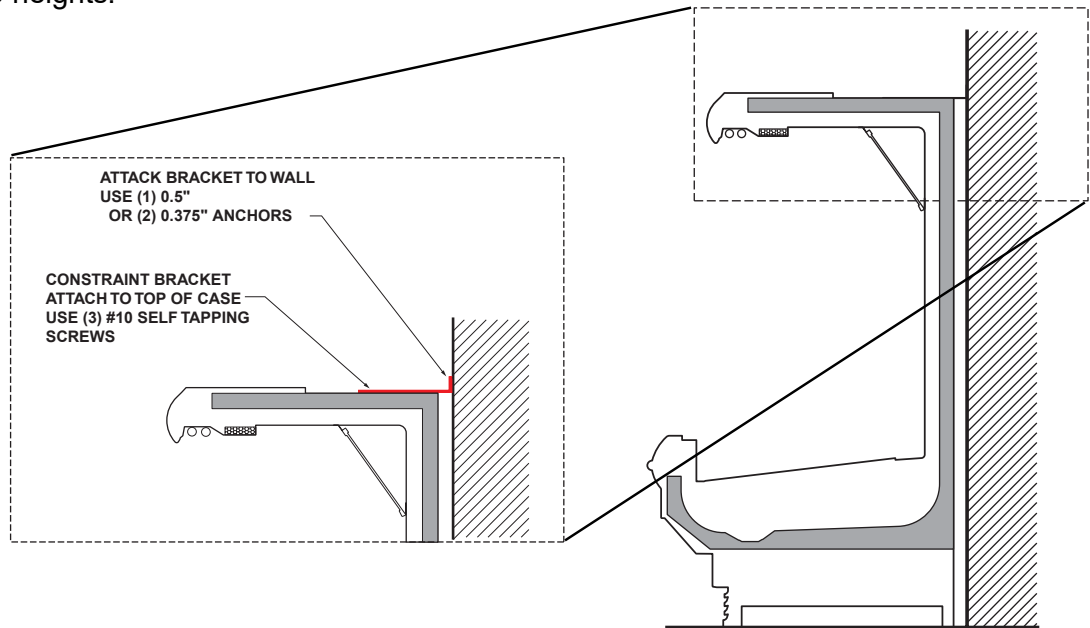

OPTION 2

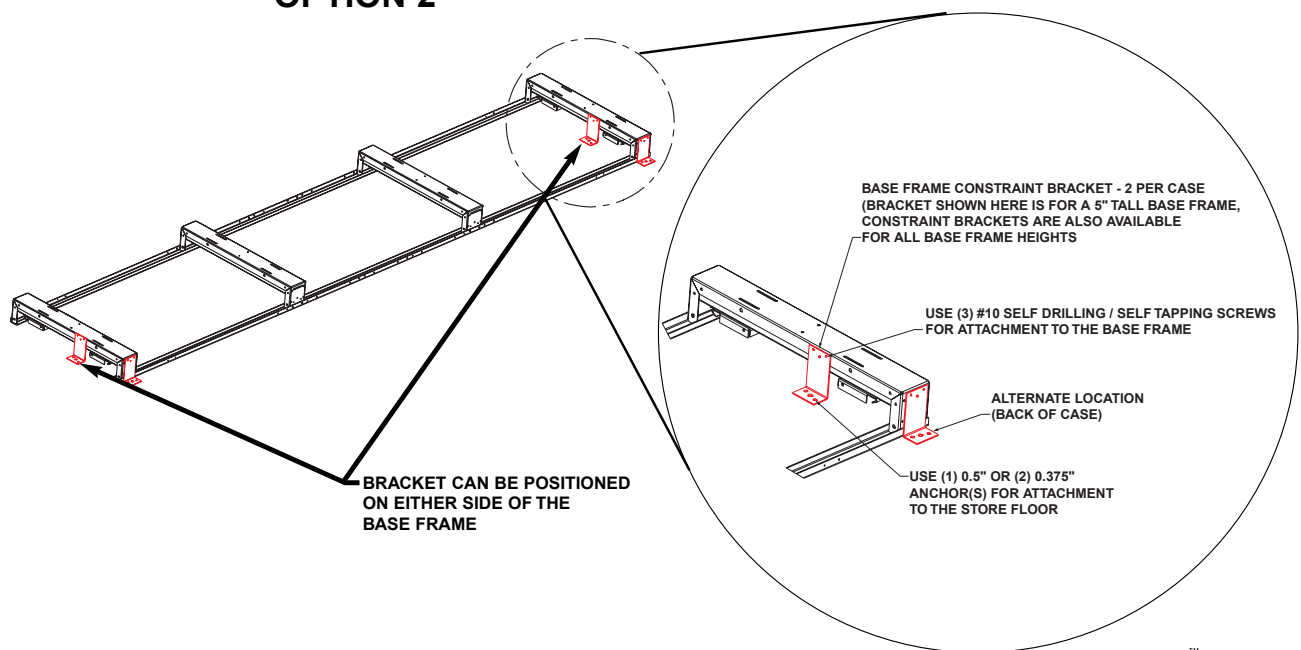

15" BRACKETS

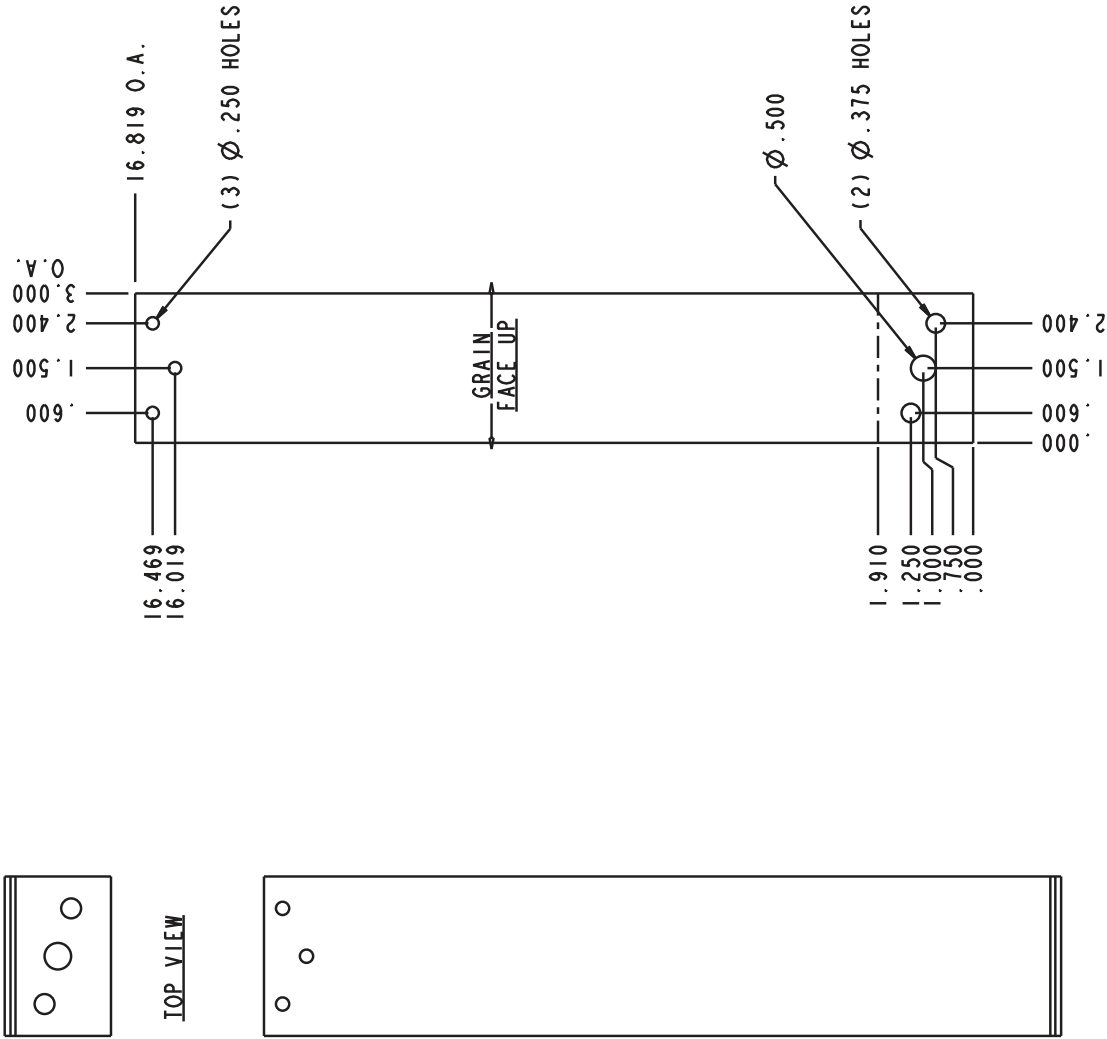

ALL BENDS 90° UNLESS SPECIFIED	SURFACE:	GL
ALL DIMENSIONS UNLESS OTHERWISE SPECIFIED	TYPE:	MSP
DEGREES ± 1° 3 PLG DECIMALS ± .010	THICKNESS:	12G
DRAWING NOT TO SCALE	FINISH:	GALVANIZED
⊕ = VARIANCE ACCEPTABLE	PART NUMBER:	F766807EGL
HILL PHOENIX		
HILL PHOENIX 1924 HILL PHOENIX ROAD COLONIAL HEIGHTS, VA 23834 PH: (804) 526-4455 FAX: (804) 526-3723		
PART DESCRIPTION: RKT 1 15" RF CONSTRT		

F1 CASE TOP FASCIA

Install the recessed coil shroud (Fig. 1), leaving about an inch of clearance on both sides of the coil. Attach the bottom of the fascia baffle (Fig. 2) to the coil shroud using the pre-punched screw holes.

Next, secure the bottom of the front fascia to the cornice assembly using the pre-punched screw holes (Fig. 3), then secure front fascia to the upper fascia baffle using the pre-punched screw holes (Fig. 4). Secure the bottom edge the front fascia to the case body using pre-punched screw holes.

If present, attach the two-part, adjustable end panels (Fig. 5) to the front fascia using pre-punched screw holes. Then secure end panels to the case body (Fig. 6).

When this step is complete, the controller box should be brought forward and aligned with the fascia cut-out (Fig. 7).

Finally, install all fascia joint trim (Fig. 8) along the lineup (if multi-case).



Fig. 1 Install recessed coil shroud.

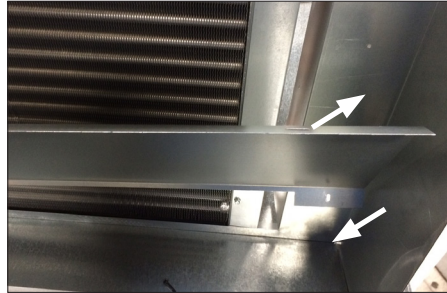

Fig. 2 Attach the bottom of the fascia baffle to the coil shroud.

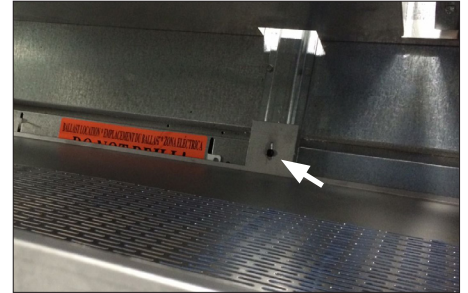

Fig. 3 Attach the bottom of the front fascia to the cornice assembly.

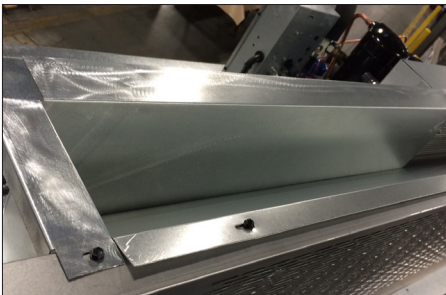

Fig. 4 Secure the front fascia to the upper fascia baffle.



Fig. 5 Attach end panel to front fascia.



Fig. 6 Attach end panel to case body.



Fig. 7 Carel controller visible through cut-out in front fascia.



Fig. 8 Fascia joint trim.

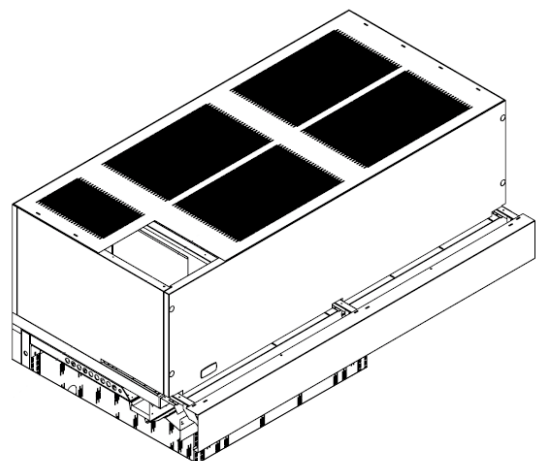

Fig. 9 Factory fascia top view.

The noise dampener helps to reduce the noise level of the condensing unit.

Slide the right-hand panel into place using the provided slot on the back of the fascia shroud (Fig. 1). Repeat on the left-side of the condenser (Fig. 2)—if you need to, cut out enough of the foam to fit over any piping that may be obstructing the panel.

Install the top panel (Fig. 3) by sliding under the protruding metal edge of the fascia shroud, then fitting the top panel's "teeth" into the cut-outs of the side panels to complete the installation (Fig. 4).



Fig. 1 Attach right-hand panel to front fascia.



Fig. 2 Attach left-hand panel to front fascia.

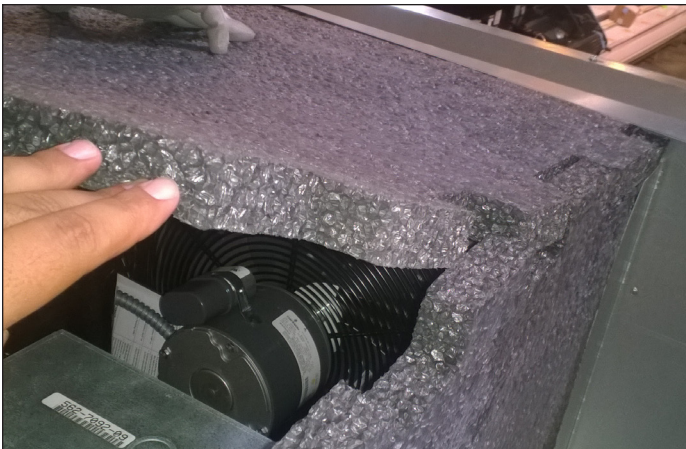

Fig. 3 Top panel installs under metal edge, fitting into pre-cut slots.



Fig. 4 Complete assembly.

G1 MIRROR ASSEMBLY

Mirror scoops, air deflectors, and mirrors will be packaged in a protective wrapping (Fig. 1). Unwrap the mirror scoop and air deflectors.

Both the top and bottom mirror retainers are pre-installed during the manufacturing process (Fig. 2). Install the mirror scoop, leaving one row of holes between the mirror scoop and the bottom mirror retainers (Fig. 3). Install the mirror scoop air deflector directly below the bottom mirror retainers. There will be some overlap of these 2 components (Fig. 3).

Unwrap and install the mirrors using the top and bottom mirror retainers. The full assembly is shown in Figure 4.

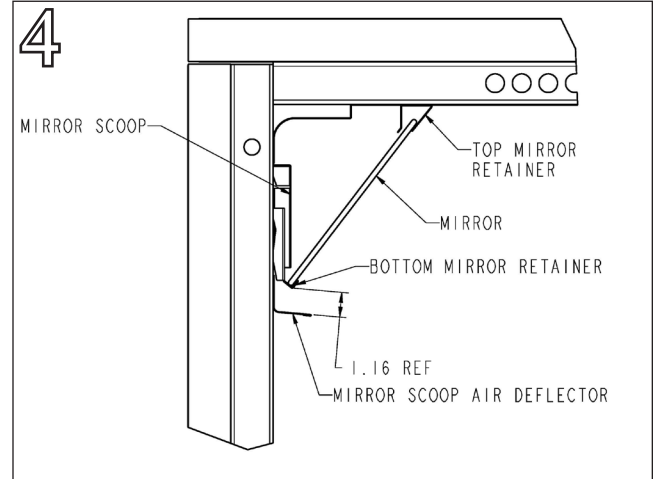
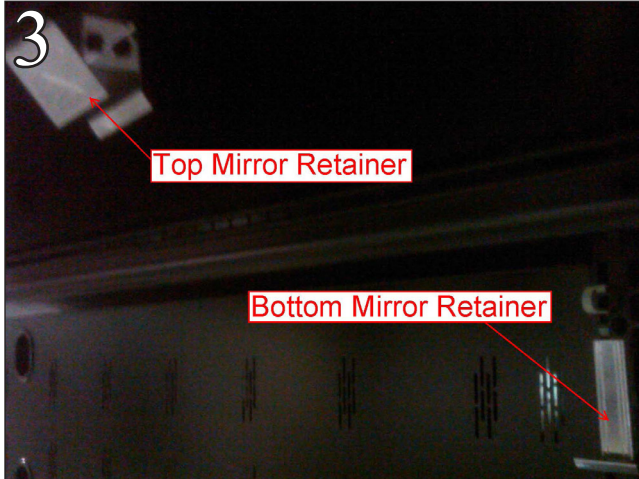
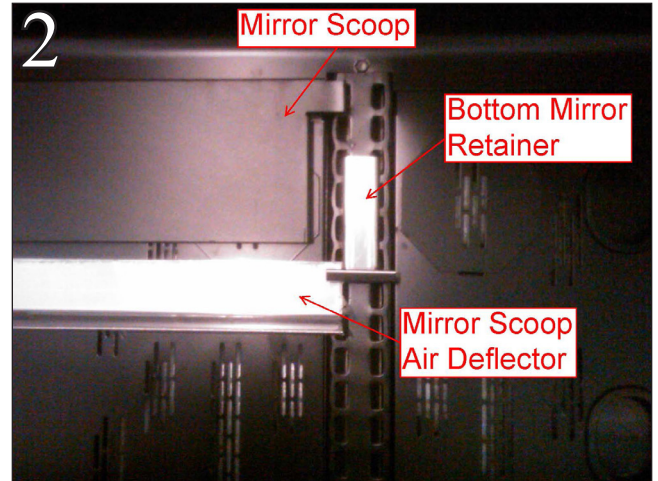
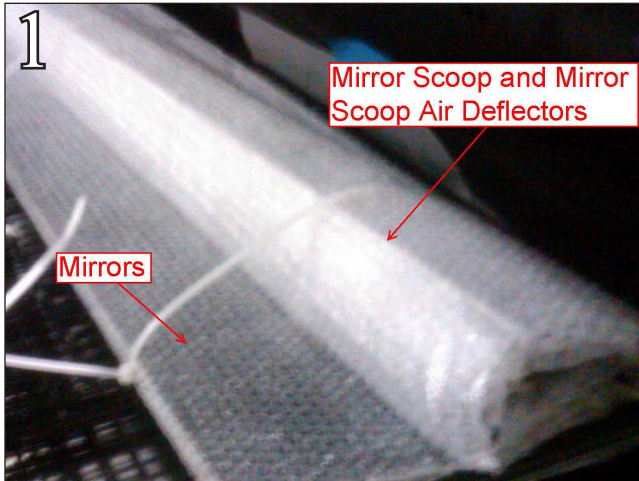

Shelf fillers (Fig. 1) are included to ensure that proper airflow is maintained when shelves are placed in an angled position.

To install, remove the shelves, then snap the shelf filler into place on the shelf (Fig. 2).

Once the shelf is re-installed with the attached shelf filler, push the shelf filler back until it is flush with the rear baffle (Fig. 3) to ensure proper airflow within the display area.

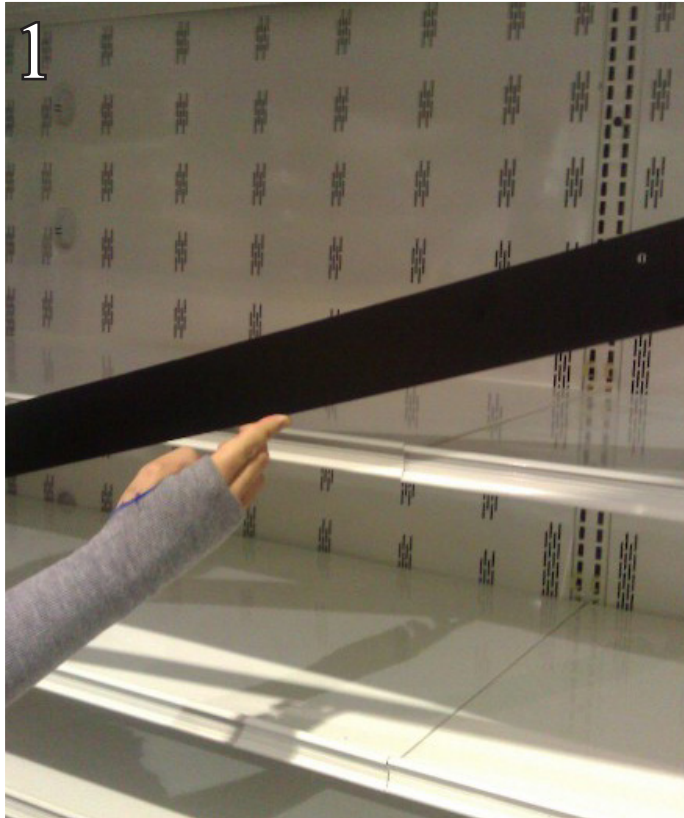

I1 PEG HOOKS

When a case merchandiser's shelves are removed, air drifts back to the rear duct and swirls around, thus breaking the protective air envelope and allowing case air to mix with ambient store air (Fig. 1). When the shelves are present, air flows from the top and back, forming a protective barrier against the ambient store air (Fig. 2).

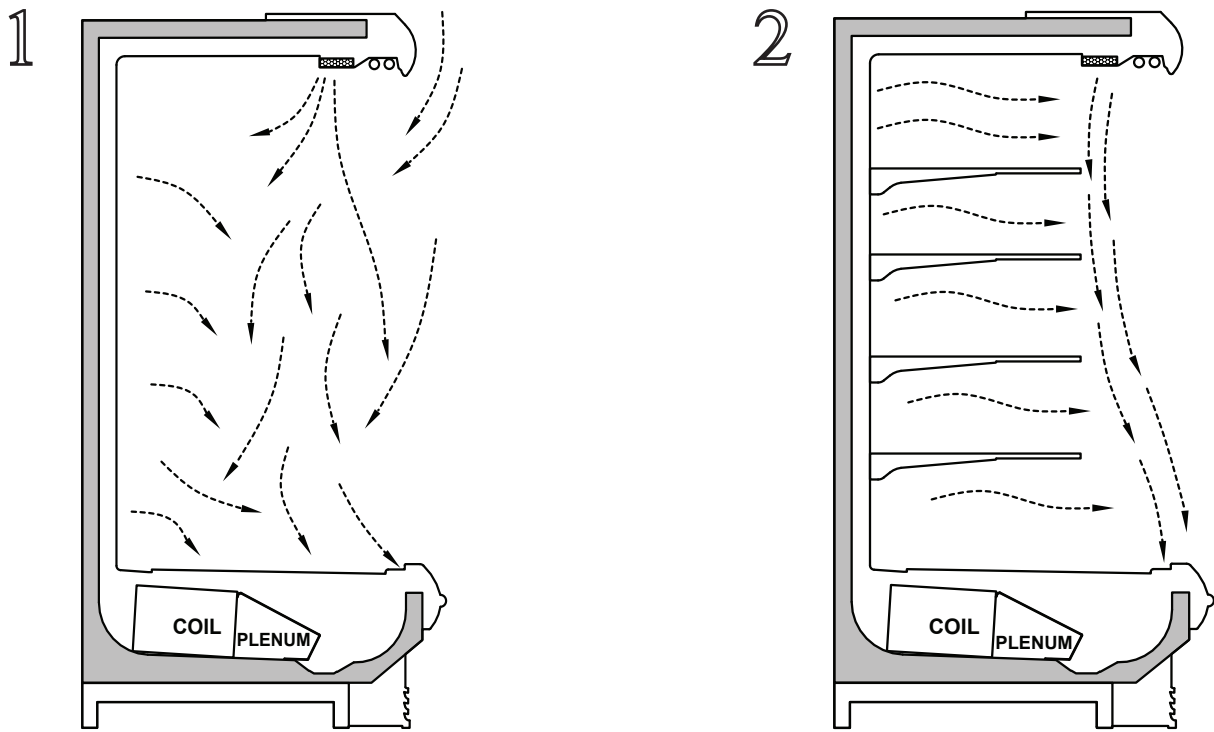

When peg bars are present, air falls through openings between packages and fails to maintain a protective barrier (Fig. 3). When the bars are fully stocked, the effect is minimized; however, product temperatures will not be optimal. Sweating may be noticed on the top duct panel above the bars and frost will build up on the coil faster, requiring more frequent defrost cycles. For proper set-up of a merchandiser with peg bars, install a solid baffle above each row of peg bars - except for the bottom shelf - to maintain proper air flow and temperatures inside the case. Non-load-bearing solid air baffles should run the same width as the peg bars.

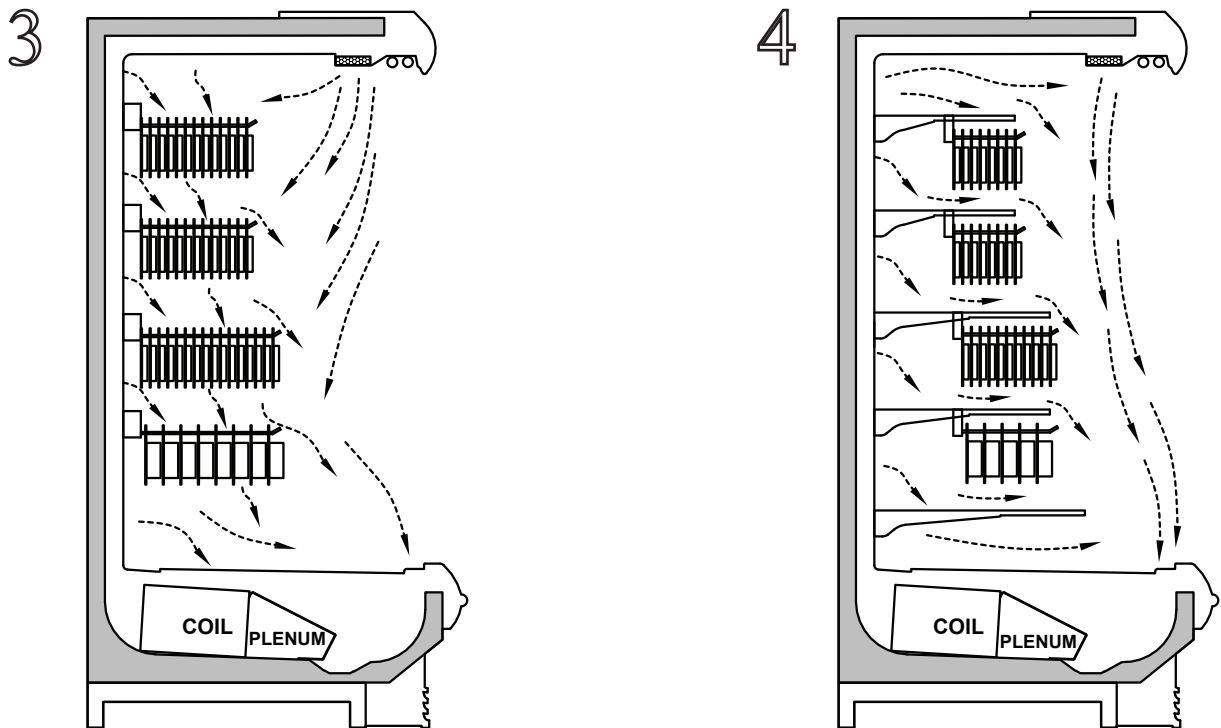

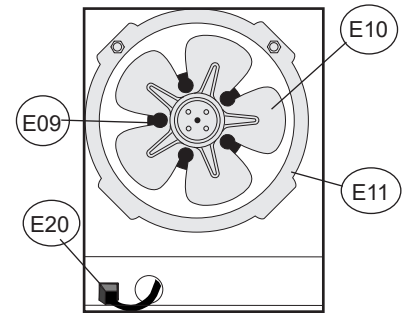
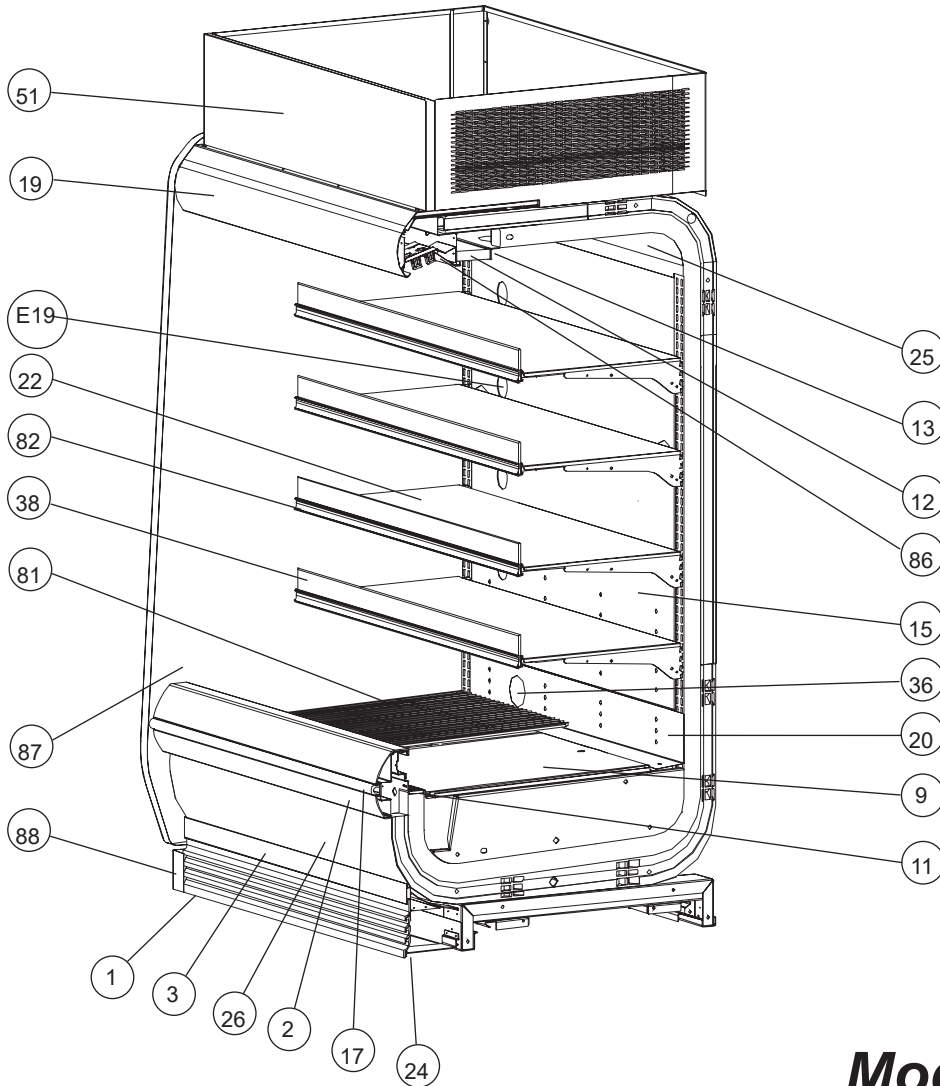

Model O5DMA

Location Number	Part Descriptions
1	Kickplate
2	Master Bumper
3	Lower Front Panel
9	Deck Pan
11	Front Baffle
12	Honeycomb
13	Honeycomb Retainer
15	Upper Rear Baffle
17	Nose Bumper
19	Cornice
20	Lower Rear Baffle
22	Shelves
24	"J" Rail
25	Top Flue Panel
26	Front Panel
36	Plug Button
38	Shelf Package Stop
50	Lamp Shield
51	Compressor Shroud
69	Coil
75	Drain Pan
81	Wire Racks
82	Shelf Tag Moulding
83	Thermometer
86	Light Reflector
87	End Assembly
88	End Kickplate
E05	Light Switch
E06	Lamp Holder
E07	Lamp
E08	Ballast
E09	Fan Motor
E10	Fan Blade
E11	Fan Basket
E19	Receptacle
E20	Fan Cord-Set



A  COMPANY

LIMITED & GENERAL WARRANTY TERMS

Hill Phoenix, Inc's. (hereinafter "Hillphoenix") products are warranted to be free from defects in materials and workmanship under normal use and maintenance for a period of 14 months from date and place of shipment from Hillphoenix (the "Base Warranty Period"), provided that the installation and maintenance of such products have been performed strictly in accordance with Hillphoenix's designated specifications.

Anthony products supplied as original equipment on Hillphoenix products receive Hillphoenix warranty.

All warranty repairs must be approved in advance before services are started. In the event of a qualifying warranty claim, the extent of Hillphoenix's liability under the Warranty is limited to the repair or replacement, at Hillphoenix's option, of any non-conforming products without charge. If required, a new or rebuilt part to replace any defective part will be provided without charge and will be shipped via standard ground freight, with shipping charges being covered by Hillphoenix during the base warranty period. The replacement part is covered under this warranty for the remainder of the applicable Base Warranty Period. In order to be eligible for warranty coverage, customer must: (i) notify Hillphoenix in writing within twenty-four hours upon discovery of a warrant defect, and (ii) comply with the warranty claim procedures provided by Hillphoenix from time to time. These warranty terms are incorporated into and governed by the Hill Phoenix Terms and Conditions of Sale.

This equipment warranty does not include labor or other costs incurred for diagnosing, repairing, removing, installing, shipping, servicing, or handling of either defective parts or replacement parts. Unauthorized modifications to set-points, parameters, and controls may result in deteriorated performance and/or equipment failure. Any unauthorized modifications could result in the warranty being voided.

The warranty shall not apply:

1. To any unit or any part thereof which has been subject to an accident, alteration, negligence, misuse or abuse, or which has not been operated in accordance with the manufacturer's recommendations, or in conditions outside of Manufacturer's specifications, or if the serial number of the unit has been altered, defaced, or removed.
2. When the unit, or any part thereof, is damaged by fire, flood, or other act of God.
3. To products that are impaired or damaged due to improper installation.
4. When installation and startup forms are not properly completed or returned within two weeks after startup.
5. If the defective part is not returned to the Manufacturer.
6. To service, maintenance or wear and tear parts (such as lights, starters and ballasts).
7. To cosmetic damage (e.g., scratches, dents, chips, and other damage to appliance finishes), unless such damage results from defects in materials and workmanship and is reported to Hillphoenix within 30 days from date of purchase.
8. To shipping damage.
9. To use in a non-commercial application.
10. Corrosion, discoloration, oxidation, or rust due to exposure to predisposed corrosive environments/atmospheres or contact with product damaging material/chemicals.
11. To service trips where no problem is diagnosed or found in the discretion of Hillphoenix.
12. To Removal/reinstallation of product for repair if installed in an inaccessible location.
13. To use of non-OEM parts for warrantable repair unless directed by Hillphoenix.
14. To repair/service tools/items.
15. To service trips to teach customer how to use product.
16. To product pick-up or delivery for repair purposes; repairs should take place on the customer's site unless directed by Hillphoenix.
17. To misdiagnosis or misrepair, including subsequent labor/component repair or replacement.
18. To stolen components.
19. To replacement service parts lost or misplaced on arrival by receiving personnel.
20. To service events on non-DFR products.
21. To excess repair time.
22. To excess required consumables charges, at the discretion of Hillphoenix.
23. If a service contractor takes longer than 120 days from the date of repair completion to submit a warranty invoice/claim.
24. To component/equipment failures, equipment shutdowns, operational performance degradation due to deviations and unauthorized changes to required and/or recommended set-points, parameters, and controls.

Examples of non-warrantable situations include, but are not limited to:

- Non-factory electrical connection or component issues
- Product is operated on low or improper voltages
- Use of extension cords to power the product

- Lack of basic preventative maintenance as outlined by product manuals
- Installation into a mobile application
- Failures or symptoms that result from site mechanical or electrical failures
- Loading of food or other content that prevents the product from operating properly
- 'Yellowing' of lighting products
- Any physical modifications or changes to product(s) will invalidate the warranty

MODIFICATIONS TO GENERAL WARRANTY

The following sets forth certain modifications to the General Warranty for specific products of Manufacturer:

DISPLAY CASE AND SPECIALTY PRODUCTS CLEARVOYANT® LED LIGHTING

The warranty period for Clearvoyant LED lighting components within the Clearvoyant lighting system is five years from date of shipment.

NO WARRANTY FOR NON-STANDARD PRODUCTS

A " Non-Standard Product" is any product that is different in any manner from any Hillphoenix product that has been previously designed and manufactured by Hillphoenix in accordance with its standard specifications. A Non-Standard Product also includes any standard Hillphoenix product that has been specially designed or modified to meet a particular Buyer specification, or that contains any additional or substituted product, part, accessory, equipment, fixture, component or material, or that has been assembled, manufactured, produced, or installed by any method or process, which is different from Hillphoenix' s standard specifications for such product. Hillphoenix expressly disclaims and makes no warranties, express or implied, as to the condition, design, utility, quality, adequacy, or capacity with respect to any standard or Non-Standard Product, including, without limitation, any warranty of merchantability or fitness of such product for a particular purpose or intended use, whether or not such product has been designated by Hillphoenix as a Non-Standard Product. All Non-Standard Products, whether sold separately, or incorporated and/or attached to standard Hillphoenix products, and all services relating to such products, are sold to and accepted by Buyer " as is" and "with all faults". Without limiting any other provision of this purchase order, Hillphoenix shall have no liability to Buyer for any claim, loss, damage, consequential damages or expenses associated with any Non-Standard Product and/or its use or operation, or any other equipment or property of Buyer caused by or alleged by to be caused by any such product or its use or operation, whether directly, indirectly, incidentally or consequentially, or by any inadequacy thereof or deficiency or defect therein. The foregoing exclusion of warranty cannot be modified or waived except as expressly set forth in a writing signed by an officer of Hillphoenix authorized to make such modification or waiver.

REMEDY LIMITATION/DAMAGES EXCLUSION

THE REMEDY OF REPAIR OR PROVISION OF A REPLACEMENT PART WITHOUT CHARGE SHALL BE THE EXCLUSIVE REMEDY FOR ANY WARRANTY CLAIM HEREUNDER. WITHOUT LIMITING THE FOREGOING, HILLPHOENIX SHALL NOT BE LIABLE UNDER ANY CIRCUMSTANCES FOR INCIDENTAL, INDIRECT, LIQUIDATED OR CONSEQUENTIAL DAMAGES, INCLUDING LOSS OF PROFIT, LABOR COST, LOSS OF REFRIGERANT OR FOOD PRODUCTS.

EXCLUSIVE WARRANTY

THE FOREGOING WARRANTY IS THE EXCLUSIVE WARRANTY WITH RESPECT TO THE PRODUCTS. ALL OTHER WARRANTIES, WHETHER EXPRESS OR IMPLIED, INCLUDING WITHOUT LIMITATION, THE WARRANTIES OF MERCHANTABILITY OR FITNESS FOR A PARTICULAR PURPOSE, ARE HEREBY DISCLAIMED AND EXCLUDED. NO IMPLIED WARRANTY SHALL BE DEEMED CREATED BY COURSE OF DEALING OR USAGE OF TRADE. NO OTHER PERSON IS AUTHORIZED TO EXPAND OR CREATE ANY OBLIGATION GREATER THAN OR MORE EXPANSIVE THAN THE WARRANTY PROVIDED HEREIN.

THE ABOVE WARRANTY IS GIVEN IN LIEU OF ALL OTHER WARRANTIES, EXPRESSED OR IMPLIED, INCLUDING ANY IMPLIED WARRANTIES OF MERCHANTABILITY OR FITNESS FOR A PARTICULAR PURPOSE. HILLPHOENIX SHALL NOT BE RESPONSIBLE FOR INCIDENTAL OR CONSEQUENTIAL DAMAGES INCLUDING BUT NOT LIMITED TO INJURY TO PERSONS OR PROPERTY. NOTWITHSTANDING ANYTHING TO THE CONTRARY, HILLPHOENIX'S ENTIRE LIABILITY, AND BUYER'S EXCLUSIVE REMEDY, IN LAW AND EQUITY OR OTHERWISE, WITH RESPECT TO ANY PRODUCTS PROVIDED BY HILLPHOENIX IS SOLELY LIMITED TO THE AMOUNT PAID BY BUYER FOR THE PRODUCTS TO WHICH THE APPLICABLE CLAIM RELATES.

THIS DOCUMENT DOES NOT GOVERN EXTENDED WARRANTIES AND ANY EXTENDED WARRANTIES PROVIDED BY HILLPHOENIX SHALL BE GOVERNED BY A SEPARATE DOCUMENT AGREED UPON BY HILLPHOENIX

Submit warranty claims to: hpx-warranty-wa-invoices@doverfoodretail.com

For warranty service, please contact Hill Phoenix at: Phone: 1-833-280-5714

Warning Servicing & Case Care

When servicing or cleaning cases, observe the following procedures to avoid case damage or injury:

Be certain that all electricity to the case is turned off before servicing or cleaning to avoid electrical shock. In some cases, more than one switch may need to be turned off to completely de-energize the case.

Do not spray cleaning solution or water directly on fan motors or any electrical connections.

All lighting components must be dried thoroughly before installation and before re-energizing the lighting circuit.

Please refer to the Case Cleaning section of this installation manual.

Hillphoenix
1925 Ruffin Mill Rd.
Colonial Heights, VA 23834
Mon.-Fri. (8 a.m. to 5 p.m. EST)
Tel: 1-800-283-1109
Fax: 804-526-7450
Web site: www.hillphoenix.com

Due to our commitment to continuous improvement, all specifications are subject to change without notice.
Hillphoenix is a Sustaining Member of the American Society of Quality.

**Fresh thinking.
Responsible solutions.™**



Hillphoenix®

A  **DOVER**™ COMPANY