



MULTI-DECK MERCHANDISER INSTALLATION & OPERATIONS MANUAL

PTD-R-R BAKERY / BEVERAGE / DELI

Table of Contents

Technical Reference	2-6	Pre-Power Checklist	13
General Information	7	Airflow & Defrost	14
Installation	8-9	Case Cleaning	15-16
Case Connections	10	Parts Ordering	17
Lighting & Power Supplies	11-12	Appendices	

To ensure proper functionality and optimum performance, it is STRONGLY recommended that Hillphoenix specialty cases be installed/serviced by qualified technicians who have experience working with commercial refrigerated display merchandisers and storage cabinets. For a list of Hillphoenix-authorized installation/service contractors, please visit our website at www.hillphoenix.com.

Hillphoenix[®]
a **DOVER** company





a **DOVER** company

LIABILITY NOTICE

For Cases with Shelf Lighting Systems

Hillphoenix does NOT design any of its shelf lighting systems or any of its display cases with shelf lighting systems for direct or indirect exposure to water or other liquids. The use of a misting system or water hose on a display case with a shelf lighting system, resulting in the direct or indirect exposure of the lighting system to water, can lead to a number of serious issues (including, without limitation, electrical failures, fire, electric shock, and mold) in turn resulting in personal injury, death, sickness, and/or serious property damage (including, without limitation, to the display itself, to the location where the display is situated [e.g., store] and to any surrounding property). DO NOT use misting systems, water hoses or other devices that spray liquids in Hillphoenix display cases with lighted shelves.

If a misting system or water hose is installed or used on a display case with a shelf lighting system, then Hillphoenix shall not be subject to any obligations or liabilities (whether arising out of breach of contract, warranty, tort [including negligence], strict liability or other theories of law) directly or indirectly resulting from, arising out of or related to such installation or use, including, without limitation, any personal injury, death or property damage resulting from an electrical failure, fire, electric shock, or mold.

P079211M, REVO

R-744 (CO₂) NOTICE

For Systems Utilizing R-744 (CO₂) Refrigerant

For refrigeration units that utilize R-744 (CO₂), pressure relief and pressure-regulating relief valves may need to be installed based on the system capacity. The valves need to be located such that no stop valve is positioned between the relief valves and the parts or section of the system being protected.

When de-energizing refrigeration units containing R-744 (CO₂), venting of the R-744 (CO₂) refrigerant may occur through the pressure regulating relief valves. *These valves are located on the refrigeration system and not on the case model.* If venting does occur, the valve must not be defeated, capped, or altered by any means.

WARNING: Under no circumstances should any component be replaced or added without consulting Hillphoenix Field Service Engineering. Utilizing improper components may result in serious injury to persons or damage to the system.

Important

At Hillphoenix[®], the safety of our customers and employees, as well as the ongoing performance of our products, are top priorities. To that end, we include important warning messages in all Hillphoenix installation and operations handbooks, accompanied by an alert symbol paired with the word "DANGER", "WARNING", or "CAUTION".

All warning messages will inform you of the potential hazard; how to reduce the risk of case damage, personal injury or death; and what may happen if the instructions are not properly followed.

 **DANGER**

Indicates an immediate threat of death or serious injury if all instructions are not followed carefully.

 **WARNING**

Indicates a potential threat of death or serious injury if all instructions are not followed carefully.

 **CAUTION**

Indicates that failure to properly follow instructions may result in case damage.

Revision History

- new manual format_04/21
- technical reference_02/23
- technical reference and compliance_08/25
- technical reference_08/25

PTD-R-R

Self-Service Open Multi-Deck Merchandiser w/ Service Dome & DRS
4', 6', 8', 10' & 12' (Bakery/Beverage)

GENERAL NOTES:

- "---" Indicates that the feature is not an option on this case model and/or the data is not yet available at this time.
- (DRS) Dry Rear Storage
- (RRS) Refrigerated Rear Storage (optional)
- Curved glass (optional)

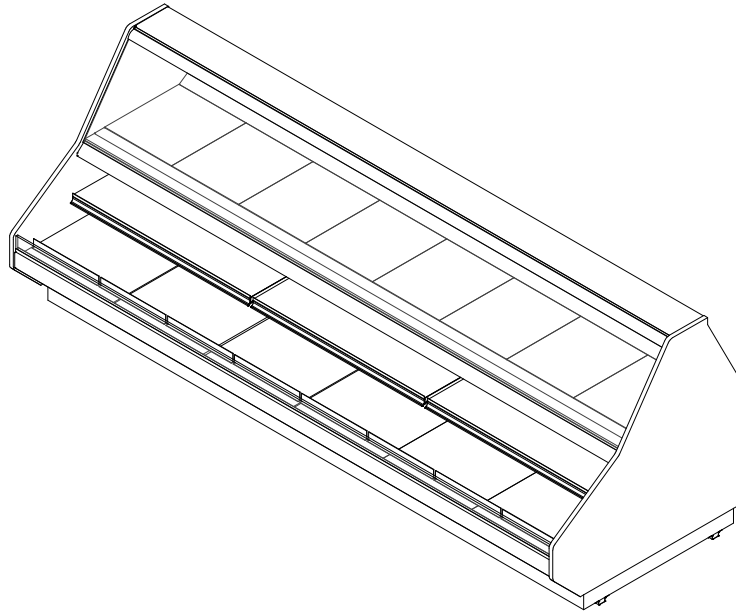

SHIPPING WEIGHT	
Case	Weight
PTD-R-R	---



ENGINEERED FOR STORES WITH AMBIENT CONDITIONS NOT TO EXCEED 75° AND 55% RELATIVE HUMIDITY. DUE TO ENGINEERING IMPROVEMENTS SPECIFICATIONS MAY CHANGE WITHOUT NOTICE. ALL MEASUREMENTS ARE TAKEN PER ASHRAE-72 SPECIFICATIONS. HILLPHOENIX REFRIGERATED DISPLAY CASES FOR SALE IN THE UNITED STATES MEET OR EXCEED DEPARTMENT OF ENERGY 2017 REQUIREMENTS. NUMBERS ARE BASED ON STANDARD CASE SIZES. CONSULT ENGINEERING.

PTD-R-R

Rev. Date	Rev. #	Rev. Title
08-25-25	3	DATA UPDATE
03-10-22	2	DATA UPDATE



PTD-R-R

Self-Service Open Multi-Deck Merchandiser w/ Service Dome & DRS
4', 6', 8', 10' & 12' (Bakery/Beverage)

ELECTRICAL DATA (DOME)											
Case Length	Fans Per Case	Box Fans		High Efficiency Fans		Anti-Condensate Heaters		Drain Heaters		Optional Defrost Heaters	
		120 Volts		120 Volts		120 Volts		120 Volts		208 Volts	
		Amps	Watts	Amps	Watts	Amps	Watts	Amps	Watts	Amps	Watts
4'	1	0.13	15.6	---	---	0.17	20.4	---	---	---	---
6'	2	0.26	31.2	---	---	0.31	37.2	---	---	---	---
8'	3	0.39	46.8	---	---	0.42	50.4	---	---	---	---
10'	4	0.52	62.4	---	---	0.52	62.4	---	---	---	---
12'	4	0.52	62.4	---	---	0.62	74.4	---	---	---	---

ELECTRICAL DATA (BASE)													
Case Length	Fans Per Case	High Efficiency Fans		Anti-Condensate Fans		Drain Heaters		Optional Defrost Heaters		RRS			
		120 Volts		120 Volts		120 Volts		208 Volts		Fans Per Case	Unit Cooler Fans		
		Amps	Watts	Amps	Watts	Amps	Watts	Amps	Watts		120 Volts		
										Amps	Watts		
4'	1	0.30	36	---	---	---	---	---	---	1	0.24	28.8	
6'	2	0.60	72	---	---	---	---	---	---	2	0.48	57.6	
8'	3	0.90	108	---	---	---	---	---	---	2	0.48	57.6	
10'	4	1.20	144	---	---	---	---	---	---	2	0.48	57.6	
12'	4	1.20	144	---	---	---	---	---	---	4	0.96	115.2	

LIGHTING DATA						
Case Length	Lights Per Row	Light Length	Clearvoyant 4 LED Lighting (Per Light Row)			
			Standard Power (Cornice or Shelf)		High Power (Cornice)	
			120 Volts		120 Volts	
			Amps	Watts	Amps	Watts
4'	1	4'	0.05	5.9	0.12	14.9
6'	2	3'	0.08	9.4	0.20	23.8
8'	2	4'	0.10	11.8	0.24	29.8
10'	2	5'	0.12	15.0	0.30	37.0
12'	3	4'	0.15	17.7	0.36	44.7

NOTES:

- "----" indicates that the feature is not an option on this case model and/or the data is not yet available at this time.
- RRS - Refrigerated Rear Storage.
- Listed BTUH indicates unlighted shelves. Add the following for lighted shelves:
4' Shelf LED: 36 BTUH
4' Canopy LED: 72 BTUH
3' Shelf LED: 27 BTUH
3' Hi-Output LED: 54 BTUH
- Listed discharge air velocity represents the average velocity at the peak of defrost.
- Discharge air temperature values represent readings taken within the upper air channel immediately behind/upstream of the honeycomb.
- * Time-off duration for defrost with no termination control.



ENGINEERED FOR STORES WITH AMBIENT CONDITIONS NOT TO EXCEED 75° AND 55% RELATIVE HUMIDITY. DUE TO ENGINEERING IMPROVEMENTS SPECIFICATIONS MAY CHANGE WITHOUT NOTICE. ALL MEASUREMENTS ARE TAKEN PER ASHRAE-72 SPECIFICATIONS. HILLPHOENIX REFRIGERATED DISPLAY CASES FOR SALE IN THE UNITED STATES MEET OR EXCEED DEPARTMENT OF ENERGY 2017 REQUIREMENTS. NUMBERS ARE BASED ON STANDARD CASE SIZES. CONSULT ENGINEERING.

PTD-R-R

Rev. Date	Rev. #	Rev. Title
08-25-25	3	DATA UPDATE
03-10-22	2	DATA UPDATE



PTD-R-R

Self-Service Open Multi-Deck Merchandiser w/ Service Dome & DRS
4', 6', 8', 10' & 12' (Bakery/Beverage)

GUIDELINES AND CONTROL SETTINGS (DX) {DIRECT EXPANSION HFC/CO2}						
	BTUH/ft		Superheat Set Point @ Bulb (°F)	Evaporator (°F)	Discharge Air (°F)	Discharge Air Velocity (FPM)
	Conventional	Parallel				
Dome	310	285	6 - 8	26	31	270
Base	485	445	6 - 8	26	29	250
RRS	109	100	10	26	29	200

DEFROST CONTROLS {DIRECT EXPANSION HFC/CO2}								
	Defrosts Per Day	Run-Off Time (Min)	Electric Defrost		Timed-Off Defrost		Hot Gas Defrost	
			Fail-Safe (Min)	Termination Temp (°F)	Fail-Safe (Min)	Termination Temp (°F)	Fail-Safe (Min)	Termination Temp (°F)
Dome	4	---	---	---	65/*36	42	---	---
Base	4	---	---	---	65/*36	42	---	---
RRS	4	---	---	---	65/*36	42	---	---



ENGINEERED FOR STORES WITH AMBIENT CONDITIONS NOT TO EXCEED 75° AND 55% RELATIVE HUMIDITY. DUE TO ENGINEERING IMPROVEMENTS SPECIFICATIONS MAY CHANGE WITHOUT NOTICE. ALL MEASUREMENTS ARE TAKEN PER ASHRAE-72 SPECIFICATIONS. HILLPHOENIX REFRIGERATED DISPLAY CASES FOR SALE IN THE UNITED STATES MEET OR EXCEED DEPARTMENT OF ENERGY 2017 REQUIREMENTS. NUMBERS ARE BASED ON STANDARD CASE SIZES. CONSULT ENGINEERING.

PTD-R-R

Rev. Date	Rev. #	Rev. Title
08-25-25	3	DATA UPDATE
03-10-22	2	DATA UPDATE



PTD-R-R

Self-Service Open Multi-Deck Merchandiser w/ Service Dome & DRS
4', 6', 8', 10' & 12' (Bakery/Beverage)

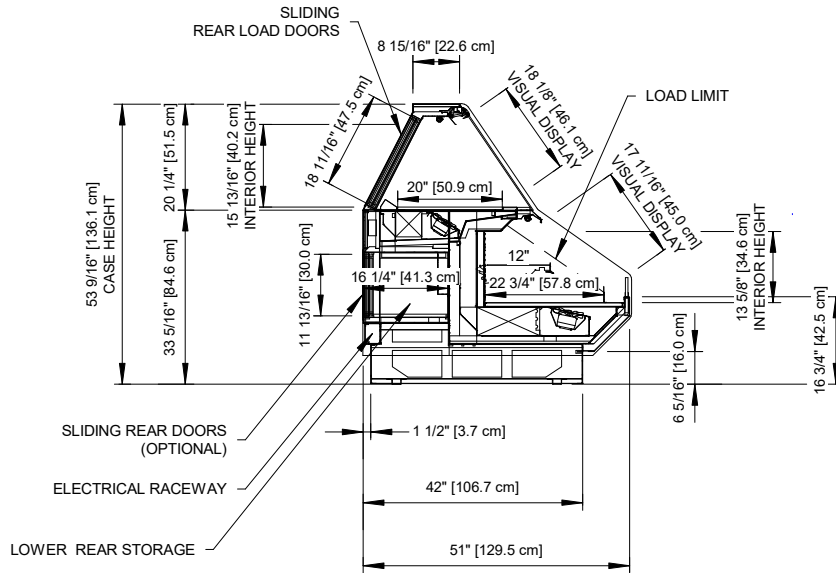

FLAT GLASS

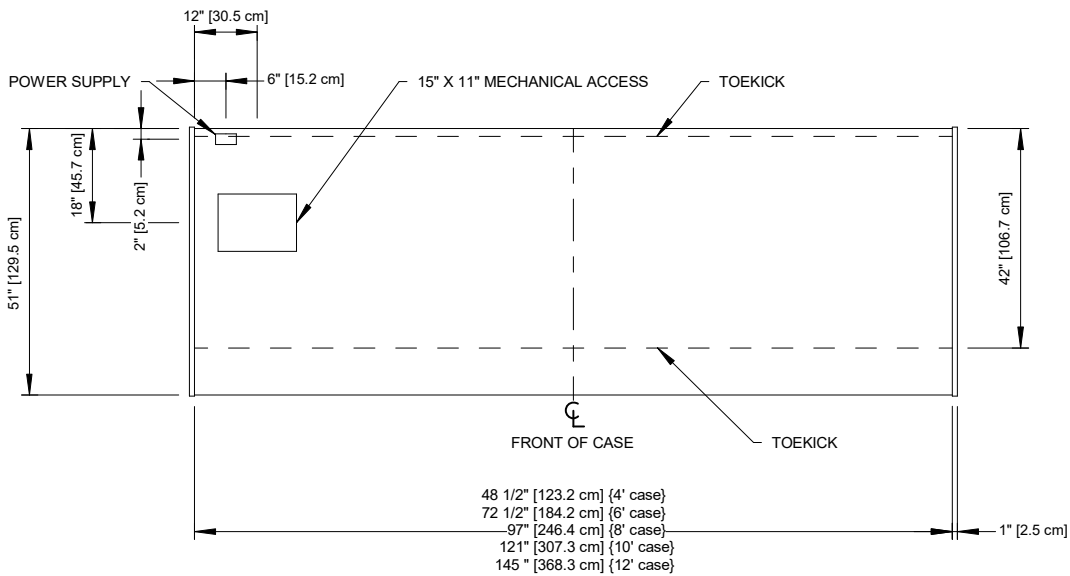

ENGINEERED FOR STORES WITH AMBIENT CONDITIONS NOT TO EXCEED 75° AND 55% RELATIVE HUMIDITY. DUE TO ENGINEERING IMPROVEMENTS SPECIFICATIONS MAY CHANGE WITHOUT NOTICE. ALL MEASUREMENTS ARE TAKEN PER ASHRAE-72 SPECIFICATIONS. HILLPHOENIX REFRIGERATED DISPLAY CASES FOR SALE IN THE UNITED STATES MEET OR EXCEED DEPARTMENT OF ENERGY 2017 REQUIREMENTS. NUMBERS ARE BASED ON STANDARD CASE SIZES. CONSULT ENGINEERING.

PTD-R-R

Rev. Date	Rev. #	Rev. Title
08-25-25	3	DATA UPDATE
03-10-22	2	DATA UPDATE



PTD-R-R

Self-Service Open Multi-Deck Merchandiser w/ Service Dome & DRS
4', 6', 8', 10' & 12' (Bakery/Beverage)

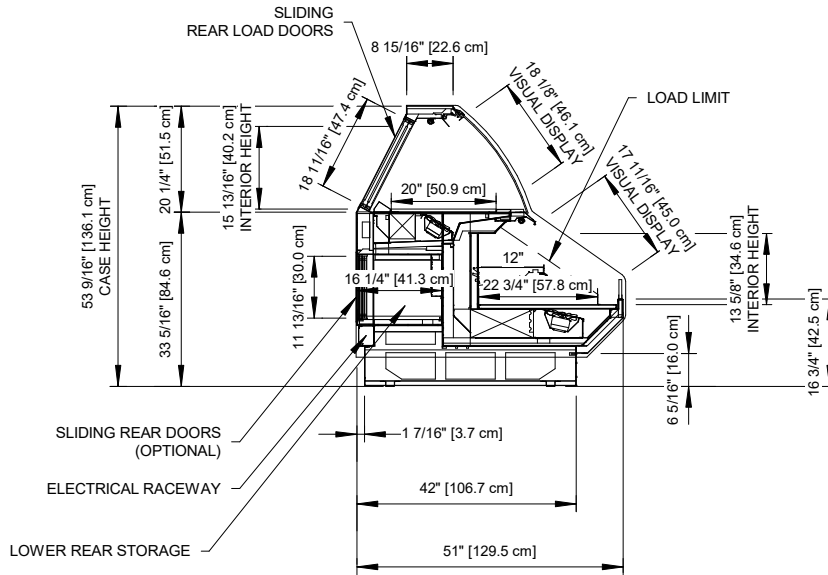

CURVED GLASS (OPTIONAL)



ENGINEERED FOR STORES WITH AMBIENT CONDITIONS NOT TO EXCEED 75° AND 55% RELATIVE HUMIDITY. DUE TO ENGINEERING IMPROVEMENTS SPECIFICATIONS MAY CHANGE WITHOUT NOTICE. ALL MEASUREMENTS ARE TAKEN PER ASHRAE-72 SPECIFICATIONS. HILLPHOENIX REFRIGERATED DISPLAY CASES FOR SALE IN THE UNITED STATES MEET OR EXCEED DEPARTMENT OF ENERGY 2017 REQUIREMENTS. NUMBERS ARE BASED ON STANDARD CASE SIZES. CONSULT ENGINEERING.

PTD-R-R

Rev. Date	Rev. #	Rev. Title
08-25-25	3	DATA UPDATE
03-10-22	2	DATA UPDATE



Thank you for choosing Hillphoenix for your food merchandising needs. This handbook contains important technical information and will assist you with the installation and operation of your new Hillphoenix specialty cases. By closely following the instructions, you can expect peak performance; attractive fit and finish; and long case life.

We are always interested in your suggestions for improvements (e.g. case design, technical documents, etc.). Please feel free to contact our Marketing Services group at the number listed below. Thank you for choosing Hillphoenix, and we wish you the very best in outstanding food merchandising.

CASE DESCRIPTION

This manual specifically covers the PTD-R-R bakery and beverage application self-service open multi-deck merchandiser with service dome and DRS - Dry Rear Storage.

STORE CONDITIONS

Hillphoenix cases are designed to operate in an air-conditioned store that maintains a 75° F (24° C) store temperature and 55% (max) relative humidity (ASHRAE conditions). Case operation will be adversely affected by exposure to excessively high ambient temperatures and/or humidity.

REFRIGERATION SYSTEM OPERATION

Air-cooled condensing units require adequate ventilation for efficient performance. Machine-room temperatures must be maintained at a minimum of 65° F in winter and a maximum of 95° F in summer. Minimum condensing temperatures should be no less than 70° F.

SHIPPING CASES

Transportation companies assume all liability from the time a shipment is received by them until the time it is delivered to the consumer. Our liability ceases at the time of shipment.

RECEIVING CASES

Examine fixtures carefully and in the event of shipping damage and/or shortages, please contact the Service Parts Department at the number listed below.

CASE DAMAGE

Claims for obvious damage must be 1) noted on either the freight bill or the express receipt and 2) signed by the carrier's agent; otherwise, the carrier may refuse the claim. If damage

becomes apparent after the equipment is unpacked, retain all packing materials and submit a written request to the carrier for inspection within 14 days of receipt of the equipment.

Failure to follow this procedure will result in refusal by the carrier to honor any claims with a consequent loss to the consumer.

If a UPS shipment has been damaged, retain the damaged material, the carton and notify us at once. We will file a claim.

LOST/MISSING ITEMS

Equipment has been carefully inspected to insure the highest level of quality. Any claim for lost/missing items must be made to Hillphoenix within 48 hours of receipt of the equipment. When making a claim please use the number listed below.

SERVICE PARTS & TECHNICAL SUPPORT

For service parts questions regarding our cases, please contact our Service Parts Department at 1-844-HPX-PART (1-844-479-7278) or orderparts@doverfoodretail.com

For technical questions regarding our cases, please contact our Technical Support Department at 1-833-280-5714.

CONTACTING THE FACTORY

If you need to contact Hillphoenix regarding a specific fixture, be certain that you have both the case model number and serial number. (This information can be found on the data tag, located at the top-left interior, rear exterior panel or interior rear lower storage of the case. *Location may vary based on case design.*)

Hillphoenix Specialty Products
703 Franklin Street, PO Box 478
Keosauqua, IA 52565
Website: www.hillphoenix.com

CASE INSTALLATION

LOCATION

This refrigerated display case has been designed for displaying and storing perishable food product. It is engineered for air-conditioned stores with a maximum ambient of 75°F and 55% relative humidity.

When selecting the location for placement of this case, avoid the following conditions:

Excessive Air Movement

1. Doors
2. Air-conditioned vents
3. Other air sources

Excessive Heat

1. Windows
2. Sun
3. Flood lamps 8 feet or less from the product
4. Other heat sources

FLOOR PREP

1. Ask the general contractor if your current copy of the building dimensions are the most recently issued. Also, ask for the points of reference from which you should take dimensions to locate the cases.
2. Using chalk lines or a laser transit, mark the floor where the cases are to be located for the entire lineup. The lines should coincide with the outside edges of the case feet.
3. Move case as close as possible to its permanent location. Remove all crating and shipping braces above the shipping pallet. Loosen the plastic dust cover from the pallet, but leave cover over the case to protect it while removing the case from the pallet.
4. Shipping braces with a sled runner construction can either have metal brackets that can be removed with a screw gun, or wood blocks that can be removed with a J-bar.
Note: Shipping braces are normally located at each corner of the case. (Shipping braces used vary and are based on case design for best transport.)
5. Carefully, if horizontal supports, lift case up and off the pallet. Remove dust cover. Installation hardware ships in a marked packet located inside the case. Remove dust cover. Installation hardware ships in a marked packet located inside the case.
6. Leveling is necessary to ensure proper operation of the refrigeration system and drainage of the condensate. Locate the highest point on the positioning lines as a reference for determining the proper height of the shim-pack levelers. A laser transit is recommended for precision and requires just one person. Level adjustable feet by twisting, if applicable, or shim as necessary under horizontal sup-

ports as this will help ensure that the case is not settling over time.

7. Locate horizontal support positions along the chalk line (Fig. 1). Spot properly leveled shim packs at each support location.

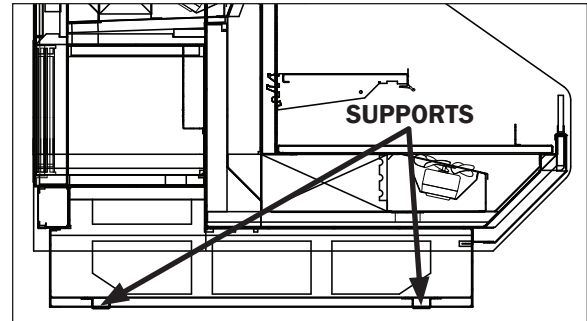

Fig. 1 Horizontal supports

8. If necessary, drill a hole in each end of every horizontal support (Fig. 2) and fasten to the floor with concrete anchors. **Note: The holes do not need to be in the exact locations specified here. Be sure that the anchors are close to the end of the horizontal supports and at each corner of the case.**

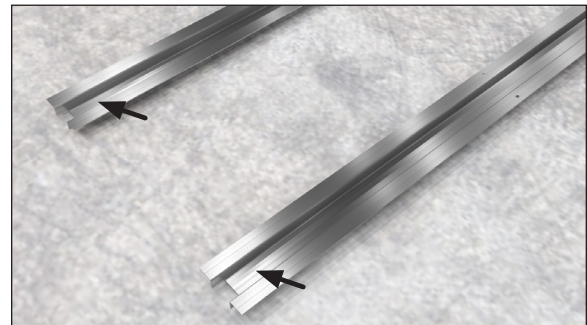

Fig. 2 Seismic anchoring locations

CAUTION

Locate the horizontal supports under unit before removing from pallet. Failure to do so will damage the finished metal if correct lift points are not identified prior to removal.

CAUTION

These cases are not designed for excessive external weight. Do not walk on top or inside of cases. Doing so may result in case damage and/or personal injury.

LINE-UP & INSTALLATION

Single Case

1. Move the case into position. Using a "J" bar, raise the end

of the case (under cross support), and lower the horizontal support on to the shim packs. Repeat on the other end of the case.

⚠ WARNING

Be certain that your hands and feet are out of the way before lowering the case. Failure to do so may result in serious injury.

2. Once the case is properly placed on the shim packs, check the vertical plumb of the case by placing a bubble level on the rear wall. Add/remove shim packs as needed. For the horizontal level, repeat this process after placing the bubble level on the front sill.
3. Install the bumper, if applicable, into pre-attached bumper track and snap into place.
4. After sufficient time has passed to allow for bumper shrinkage, cut away the excess bumper for final fit and finish. Be certain to use an appropriate cutting tool (tubing- or PVC-cutter) to ensure a smooth cut.
5. Install case shelves and reconnect lights. Be aware that differing shelf configurations will affect energy consumption and case performance.
6. Install toekick back onto the base of case.
7. Equipment is designed to be sealed to the floor once installed in final location. This is intended to prevent liquid, dirt, debris, etc. from collecting under the case after installation. **Exception: Cases using casters are not required to be sealed to the floor.**

Once case is set in the final location and all panels are attached, run a bead of silicone/sealant around the bottom edge of the case and the floor to create a barrier to prevent liquid, dirt, debris, etc. from collecting underneath the case.

Multi-Case

1. Remove any shelves (discard the shelf clips) and/or loose items from the cases that may interfere with case joining. Keep all loose items as they will be used later in the installation process.
2. Follow the single-case installation instructions for the first case, excluding #6, then position the next case in the line-up approximately 3' away.
3. Apply a bead of butyl or silicone sealant to the end of the first case. From the opposite end, push the second case to a position that is approximately 6" from the first case, then position the case on the shim packs.
4. Push the cases tightly together, then lightly bolt them together through the holes provided (Fig. 3). Tighten all the joining bolts until all margins are equal. Be careful not to over tighten.
5. The stub-up location can be found under the tank on the

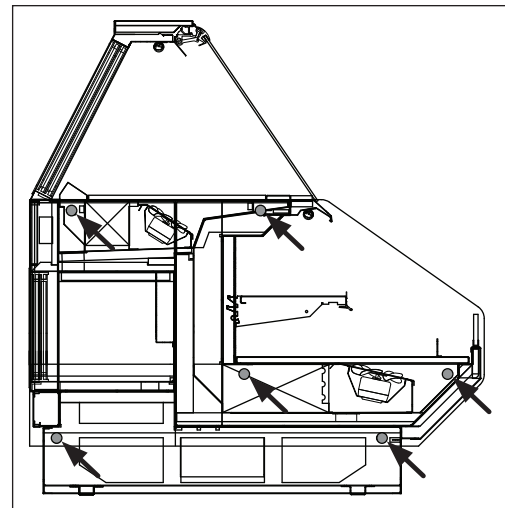

Fig. 3 Bolt locations

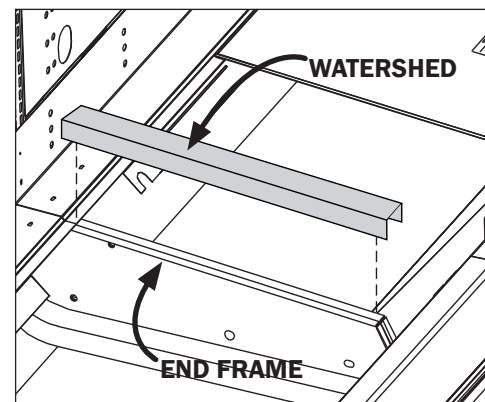

Fig. 4 Sealing the pipe chase

customer left. See technical reference on page 4 for access locations.

6. Apply case-to-case watershed (supplied) over the end frame seam (Fig. 4). The watershed prevents water from settling in the case joint.
7. Repeat steps 3-6 of this sequence for all remaining cases. Be certain to properly level all cases.
8. Properly align the front panels as needed, then install, if applicable, front panel trim (supplied).
9. Install the bumper into pre-attached bumper track and snap into place.
10. After sufficient time has passed to allow for bumper shrinkage, cut away the excess bumper for final fit and finish. Be certain to use an appropriate cutting tool (tubing- or PVC-cutter) to ensure a smooth cut.
11. Install case shelves and reconnect lights. Be aware that differing shelf configurations will affect energy consumption and case performance.
12. Install toekick back onto the base of case.

⚠ CAUTION

Installation of 3rd-party materials may result in diminished case performance.

CASE CONNECTIONS

REFRIGERATION

Refrigeration connections will be made through the refrigeration stub up location on the customer left side of the case. Refrigeration lines may be headed together for all cases in a line-up, if necessary, by lines through the access holes with a high grade silicon to prevent recirculation. All lines must be correctly sized. See *technical reference on pages 4 and 5 for access locations*.

If it becomes necessary to penetrate the case bottom for any reason, make certain it is sealed afterward with canned-foam sealant and white RTV.

CAUTION

Be certain that all piping connections are compliant with local codes.

CAUTION

If any brazing is necessary, place wet rags around the area to avoid tank damage.

PLUMBING

The drain outlet or "P" trap (Fig. 5) is shipped loose with the case and made from a 1 1/2" PVC pipe. Care should be given to ensure that all connections are water-tight and sealed with the appropriate PVC or ABS cement.

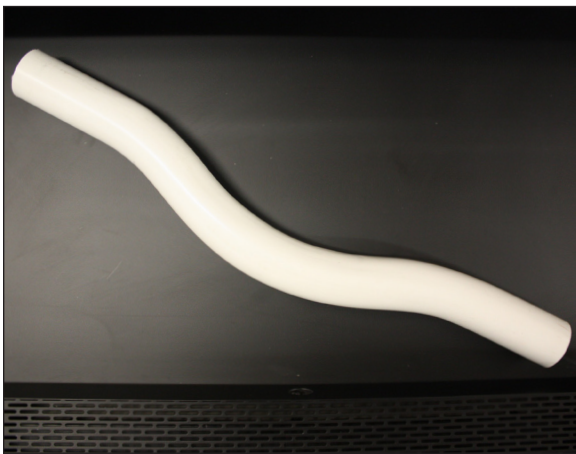

Fig. 5 "P" trap / drain outlet

Drain lines can be run left or right of the tee with the proper pitch to satisfy local drainage requirements. When connecting the PVC to the existing floor drains be sure to provide as much downhill slope as possible and avoid long runs of drain lines.

Do not install condensate drains in contact with non-insulated suction lines in order to prevent condensate from freezing. Install the 1 1/2" PVC trap, which is provided with the case. All drains must be trapped.

Before operating the case, be certain to remove the styrofoam shipping block that protects the plumbing lines during shipping.

CAUTION

Be certain that all plumbing connections are compliant with local codes.

CAUTION

Be sure to remove all styrofoam shipping blocks from piping and refrigerant lines. Failure to do so may result in case damage.

ELECTRICAL

Electrical hookups are made through the electrical raceway that can be accessed by removing the rear raceway panel.

For case-to-case wiring, run conduit between the power supply boxes or run wiring through the raceway. When connecting to the power supply on the case, field wiring should exit box from the side furthest away from case wiring to allow more room inside for wiring connections. Always check the data tag located on left end exterior panel or top interior of the case. The case must be grounded. *For more detailed electrical wiring information (see Appendix A1).*

CAUTION

Be certain that all electrical connections are compliant with local codes.

DANGER

CAUTION, RISK OF ELECTRIC SHOCK. If the cord or plug becomes damaged, replace only with a cord and plug of the same type.

GENERAL LIGHTING INFORMATION

Hillphoenix cases are equipped with LED luminaires and feature specially designed light reflectors in the cornice to improve the illumination of products. LED power supplies operate both the cornice and shelf lights and are located above the cornice reflectors.

The lighting system has an ON/OFF switch located in the raceway, power box or at the inside back of the case. Once a case has been properly positioned in the store and an electrician has connected the lighting circuit, the lights may be turned on to verify that they are connected and functioning properly.

To ensure peak performance, it is advisable to run the lighting systems only when the store climate control is on and case refrigeration is started. **Note: It is highly recommended that the ambient store temperature not exceed 80°F.**

need for any significant maintenance for several years. Should a power supply need to be removed and/or replaced, turn off the power to the case before proceeding. Be certain to replace the power supply with genuine Hillphoenix parts or a comparable UL-listed Class-2 rated regulated 24V DC power supply with 100W output capacity.

⚠ DANGER

SHOCK HAZARD

Always disconnect power to case when cleaning, servicing or configuring components of the lighting system. Failure to do so may result in serious injury or death.

⚠ WARNING

Using improper DC power supplies may damage the luminaires, resulting in sub-standard operation and increased chances of safety issues/injury.

⚠ WARNING

Never replace a 24V DC power supply with a T8 or T5 ballast of any kind! Ballasts use alternating current (AC) instead of direct current (DC) and operate at a much higher voltage than is used by this LED system. Doing so will damage the LED system and increases the chance of safety issues/injury.

LED DRIVER/POWER SUPPLY ACCESS

To gain access to the LED driver or power supplies remove the raceway cover (Fig. 6). The power supply can be located at the customer left side of the case.

REPLACING LED LIGHTS

Once store power is connected and the light circuit is energized, the Clearvoyant LED system should operate without the

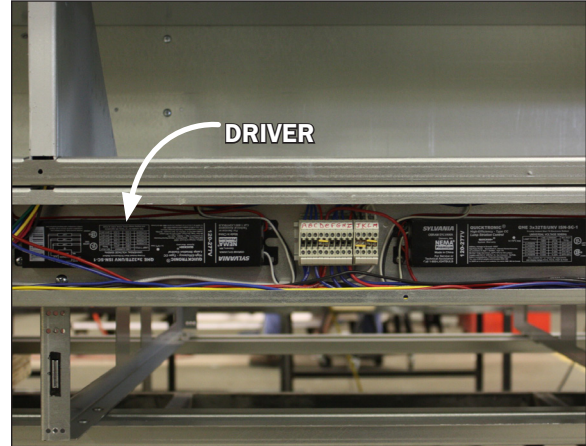

Fig. 6 Clear view of the drivers

LED LUMINAIRES

Removing LED luminaires:

1. Unplug the luminaire (Fig. 7).

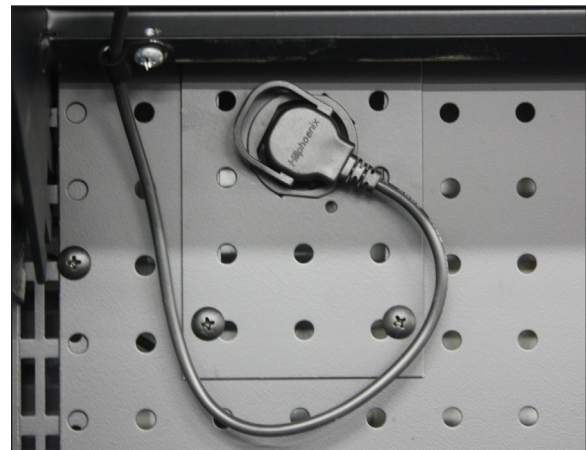

Fig. 7 LED light power cord

2. Remove the screws from the light clamps (Fig. 8) while keeping hold of the light. Once the screws are removed the light rod will come away from the case with the clamps still holding to the light.
3. Remove the closed clamps and inner rings (Fig. 9) by unclipping the clamp ends located above the screw opening. This will release the grip around the inner ring (Fig. 10) and allow for the two pieces to be separated from one another.
4. Carefully remove the inner rings from around the light rod.

⚠ CAUTION

Too much tension on the inner clamp rings while removing them from an LED light rod may cause breakage. Use only enough tension for removal.

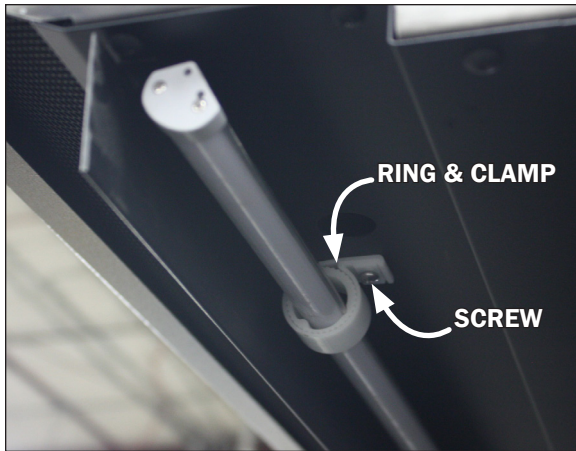

Fig. 8 LED light & ring/clamp



Fig. 11 LED ring and clamp

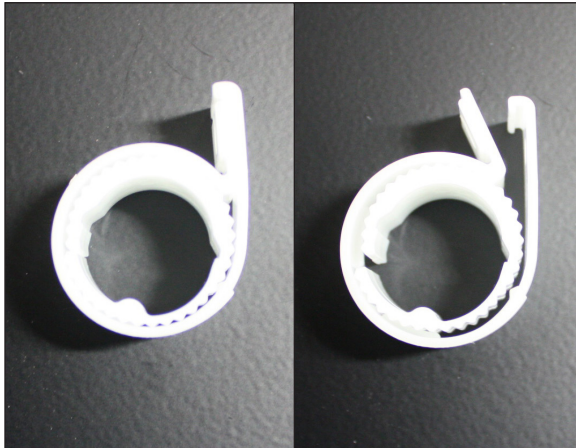

Fig. 9 Closed clamp

Fig. 10 Open clamp

Re-installing LED luminaires:

1. Place a ring (Fig. 11) around each end of the light rod and rotate until both edges of the rod line-up and snap ahold to the ridges in the ring.
2. Slide a clamp (Fig. 11) over each ring and close them tight around the rings by clipping together the clamp ends located above the screw opening.
3. Line-up the closed clamps (Fig. 9) and light rod with the existing screw holes on the case and re-attach.
4. Rotate the light rod into desired position after the clamps are firmly re-attached.

Before powering-up the case, be certain that all of the steps listed below have been completed to ensure proper case functionality, safety and compliance with warranty terms.

- Have you thoroughly examined the case for shipping damage? (see pg. 7)**
- Have you checked the vertical plumb of the case? The horizontal level? (see pg. 8)**
- Have you applied the sealant to the end breakers of adjoining cases? (see pg. 9)**
- Have you sealed the case-to-case joints by applying caulk and acrylic tape to the end frame seam? (see pg. 9)**
- Have you installed the toekick? (see pg. 9)**
- Have you removed the shipping blocks from the refrigeration and plumbing lines? (see pg. 10)**

After powering-up the case, be certain that all of the steps listed below have been completed to ensure proper case functionality, safety and compliance with warranty terms.

- 1. Check all lights to ensure they are all functioning properly.**
- 2. Check case temperature and adjust controller as needed.**

AIRFLOW & DEFROST

AIRFLOW & PRODUCT LOAD

Hillphoenix cases provide maximum product capacity within the refrigerated air envelope. Please keep products within the appropriate load limit.

It is important that you do not overload the food product display so that it impinges on the airflow pattern (Fig. 12). Overloading will cause malfunction and the loss of proper temperature levels.

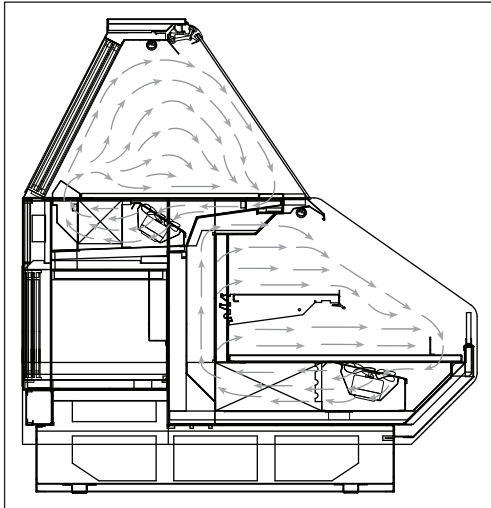

Fig. 12 Airflow pattern



WARNING

Always keep product within the designated air curtain. Failure to do so may result in case malfunction and product losing proper temperature, resulting in sub-standard operation and increased chances of food contamination.

DEFROST & TEMPERATURE CONTROLS

Cases are equipped with either Hot Gas or Timed-Off defrost at the owner's option.

The hot gas defrost termination sensor bulb and probe are attached to the dump line which is in the front, left-hand side of the case.

DETERMINING SUPERHEAT

To identify proper superheat settings, complete the following:

1. Obtain suction pressure from access port; obtain suction line temperature from area near TXV bulb at the outlet of evaporator coil.
2. Using the suction pressure reading, convert pressure to temperature using temperature pressure chart (see *Appendix C1*).

3. Finally, subtract the converted temperature reading from the actual temperature reading for superheat setting.

CASE CLEANING

A periodic cleaning schedule should be established to maintain proper sanitation, insure maximum operating efficiency, and avoid the corrosive action of food fluids on metal parts that are left on for long periods of time. We recommend cleaning once a week. Further suggestions for case cleaning include the following:

- To avoid shock hazard, be sure all electrical power is turned off before cleaning. In some installations, more than one disconnect switch may have to be turned off to completely de-energize the case.
- All surfaces pitch downward to a deep-drawn drain trough, funneling liquids to the center of the case where the waste outlet is located for easy access. Check the waste outlet to insure it is not clogged before starting the cleaning process and avoid introducing water faster than the case drain can carry it away.
- To clean the LED luminaires, shut off the lights in the case, then wipe the luminaires down with a soft, damp cloth. Avoid using harsh or abrasive cleaners as they may damage the lights. Be certain that the luminaires are completely dry before re-energizing.
- Clean from top to bottom when cleaning the display case to avoid cross contamination.
- If any potentially harmful cleaners are used, be certain to provide a temporary separator (e.g., cardboard, plastic wrap, etc.) between those cases that are being cleaned and those that may still contain product.
- Avoid spraying any cleaning liquids directly on the electrical connections.
- Allow cases to be turned off long enough to clean any frost or ice from coil and pans.
- Remove toekick and clean underneath the case with a broom and a long-handled mop. Use warm water and a disinfecting cleaning solution when cleaning underneath the cases.



DANGER

SHOCK HAZARD

Always disconnect power to case when servicing or cleaning. Failure to do so may result in serious injury or death.

Fans and Pressure Plate

1. Disconnect power to the case and wait for fans to come to a complete stand-still.
2. To access the underside of the fans first remove the screws on the top ends and front sill of the pressure plate cover (Fig. 13). Lift the pressure plate by use of the

provided lift handles (Fig. 14). There are hinges shared between the pressure plate and coil covers. **Note: It is recommended that more than one person lift the pressure plate.** The topside of pressure plate will rest against the topside of the coil cover, exposing the underside of the pressure plate and fans (Fig. 15).



CAUTION

Only lift the pressure plate and/or coil cover for a qualified inspector or a trained service provider. Failure to do so may result in damage to the refrigerant system.

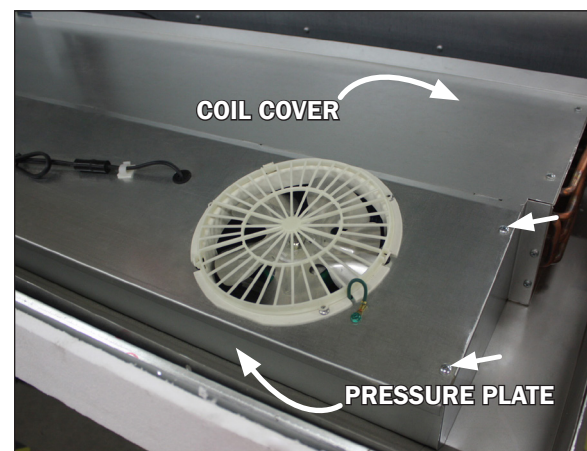

Fig. 13 Pressure plate, screw locations and coil cover (topside)

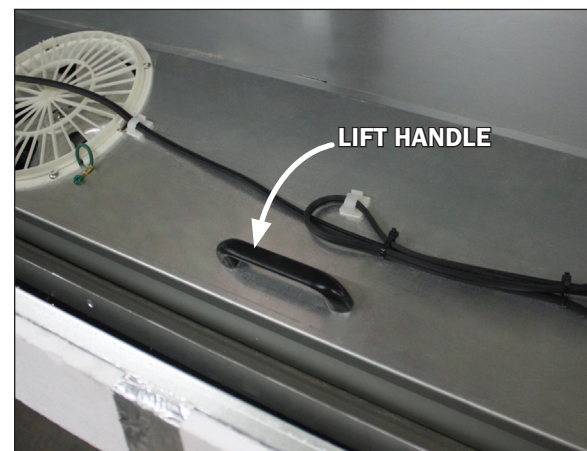

Fig. 14 Pressure plate lift handle

3. Clean as necessary. Use a spray bottle filled with an approved mild detergent and warm water.
4. Be sure to move the pressure plate back to its original position after cleaning and/or inspection is complete.

⚠ WARNING

Exercise extreme caution when working in a case with the pressure plate removed. The coil contains many sharp edges that can result in severe cuts to the hands and arms.

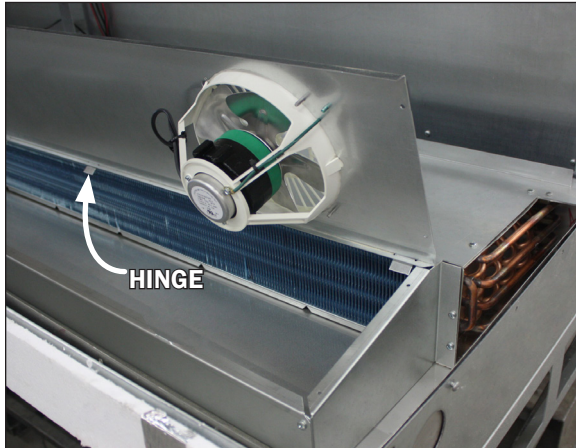

Fig. 15 Pressure plate and hinges (underside)

Coil Inspection

1. Disconnect power to the case and wait for fans to come to a complete stand-still.
2. Remove the top two screws at both ends of the coil cover (Fig. 16), as well as the screws from the top ends and front sill of the pressure plate cover (Fig. 13). **Be sure to save the removed screws for reassembly.**

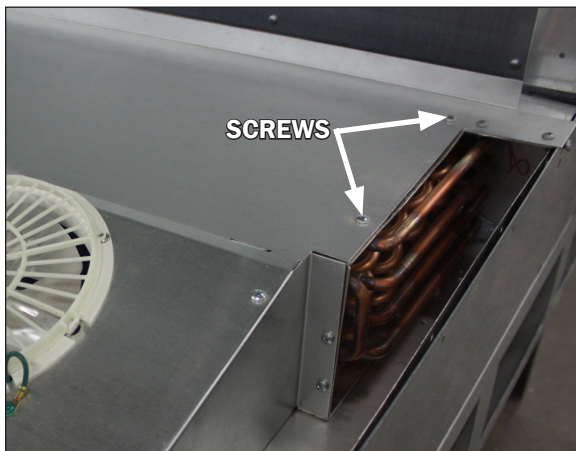

Fig. 16 Coil cover removal

⚠ WARNING

Exercise extreme caution when working in a case with the coil cover removed. The coil contains many sharp edges that can result in severe cuts to the hands and arms.

3. Carefully, without bending the sheet metal cover, with the use of the handles provided, gently slide the coil cover with the pressure plate assembly forward to expose the evaporator coil.
4. Clean as necessary. Use a spray bottle filled with an approved mild detergent and warm water. **This location should be accessed by qualified personnel only.**
5. Be sure to screw the coil cover back to its original position after cleaning and/or inspection is complete.

⚠ CAUTION

Always be sure to move the pressure plate and screw the coil cover back to their original position after the cleaning and/or inspection is complete. Failure to do so may result in damage to the refrigerant system.

Rear Load Doors

1. Remove the rear sliding doors on the back of the case and clean. To remove: push up and pull out (Fig. 17). **Note: The same applies for optional rear lower storage doors (RRS/DRS).**



Fig. 17 Rear load door removal

2. Use a spray bottle filled with an approved mild detergent and warm water.
3. Use a clean, disposable cloth (approved item) to thoroughly clean all areas of the case.
4. Wipe down doors with a clean, disposable cloth (approved item).
5. Place the cleaned doors on a clean sanitized surface until they are dry.

Hillphoenix[®]

a **DOVER** company

Contact the Service Parts Department at:

1-844-HPX-PART (1-844-479-7278)

or

orderparts@doverfoodretail.com

Provide the following information about the part you are ordering:

- **Model number and serial number*** of the case for which the part is intended.
- **Length of the part** (if applicable).
- **Color of part** (if painted) or color of polymer part.
- **Whether part is for left or right-hand application.**
- **Quantity**

***Data tag is located on the left end exterior panel or top interior of the case.**

If the parts are to be returned for credit, contact the Parts Department. Do not send parts without authorization.

APPENDIX

A1	Wiring Information
B1-B3	Dixell Operating Instructions
C1	Sporlan Pressure-Temperature Chart
D1	Parts List

A1: WIRING DIAGRAM

TBD

B1: DIXELL OPERATING INSTRUCTIONS

dIXEL

Operating Manual

1592020130

DIGITAL CONTROLLER

XR03CX – XR04CX

1. CONTENTS

1. Contents	1
2. General warnings	1
3. General description	1
4. Regulation	1
5. Defrost	1
6. Front panel commands	1
7. Parameters	1
8. Digital inputs	2
9. Installation and mounting	2
10. Electrical connections	2
11. How to use the hot key	2
12. Alarm signalling	2
13. Technical data	2
14. Connections	3
15. Default setting values	3

2. GENERAL WARNINGS

PLEASE READ BEFORE USING THIS MANUAL

- This manual is part of the product and should be kept near the instrument for easy and quick reference.
- The instrument shall not be used for purposes different from those described hereunder. It cannot be used as a safety device.
- Check the application limits before proceeding.

SAFETY PRECAUTIONS

- Check the supply voltage is correct before connecting the instrument.
- Do not expose to water or moisture: use the controller only within the operating limits avoiding sudden temperature changes with high atmospheric humidity to prevent formation of condensation
- Warning: disconnect all electrical connections before any kind of maintenance.
- Fit the probe where it is not accessible by the End User. The instrument must not be opened.
- In case of failure or faulty operation send the instrument back to the distributor or to "Dixell S.p.A." (see address) with a detailed description of the fault.
- Consider the maximum current which can be applied to each relay (see Technical Data).
- Ensure that the wires for probes, loads and the power supply are separated and far enough from each other, without crossing or intertwining.
- In case of applications in industrial environments, the use of mains filters (our mod. FT1) in parallel with inductive loads could be useful.

3. GENERAL DESCRIPTION

The XR03CX, in 32x74x50mm short format, is microprocessor based controller suitable for applications on normal temperature refrigerating units. It provides two relay output: one for compressor and the other one for alarm signalling or as auxiliary output. It provides an NTC probe input and a digital input for alarm signalling, for switching the auxiliary output or for start defrost. The instrument is fully configurable through special parameters that can be easily programmed through the keyboard or the by HOTKEY.

The XR04CX, in 32x74x50mm short format, is microprocessor based controller suitable for applications on normal or low temperature refrigerating units. It provides two relay output: one for compressor and the other one for defrost. It provides two NTC probe inputs, one for room temperature and other one to control defrost termination. The instrument is fully configurable through special parameters that can be easily programmed through the keyboard or the by HOTKEY.

4. REGULATION

The regulation is performed according to the temperature measured by the thermostat probe with a positive differential from the set point: if the temperature increases and reaches set point plus differential the compressor is started and then turned off when the temperature reaches the set point value again.

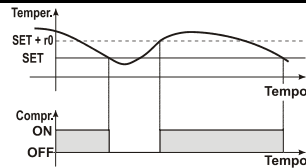

In case of fault in the thermostat probe the start and stop of the compressor are timed through parameters "Cy" and "Cn".

5. DEFROST

XR03CX

Defrost is performed through a simple stop of the compressor. Parameter "id" controls the interval between defrost cycles, while its length is controlled by parameter "Md".

XR04CX

Two defrost modes are available through the "td" parameter:

- td=EL → defrost through electrical heater (compressor OFF)
- td=in → hot gas defrost (compressor ON)

Other parameters are used to control the interval between defrost cycles (id), its maximum length (Md) and two defrost modes: timed or controlled by the evaporator's probe. At the end of defrost dripping time is started, its length is set in the dt parameter. With dt=0 the dripping time is disabled.

6. FRONT PANEL COMMANDS



SET

To display target set point, in programming mode it selects a parameter or confirm an operation



To start a manual defrost



In programming mode it browses the parameter codes or increases the displayed value



In programming mode it browses the parameter codes or decreases the displayed value

KEYS COMBINATION

- To lock or unlock the keyboard
- SET** + To enter in programming mode
- SET** + To return to room temperature display

LED	MODO	SIGNIFICATO
	On	Compressore enabled
	Flashing	Anti short cycle delay enabled (AC parameter)
	On	Defrost in progress
	Flashing	Dripping in progress
	On	Measurement unit
	Flashing	Programming mode
	On	Measurement unit
	Flashing	Programming mode

HOW TO SEE THE SET POINT

- Push and immediately release the **SET** key, the set point will be showed;
- Push and immediately release the **SET** key or wait about 5s to return to normal visualisation.

HOW TO CHANGE THE SETPOINT

- Push the **SET** key for more than 2 seconds to change the Set point value;
- The value of the set point will be displayed and the "°C" or "°F" LED starts blinking;
- To change the Set value push the o or n arrows within 10s.
- To memorise the new set point value push the **SET** key again or wait 10s.

HOW TO START A MANUAL DEFROST

Push the DEF key for more than 2 seconds and a manual defrost will start

HOW TO CHANGE A PARAMETER VALUE

To change the parameter's value operate as follows:

- Enter the Programming mode by pressing the **SET**+ keys for 3s ("°C" or "°F" LED starts blinking).
- Select the required parameter. Press the "**SET**" key to display its value
- Use or to change its value.
- Press "**SET**" to store the new value and move to the following parameter.

To exit: Press **SET**+ or wait 15s without pressing a key.

NOTE: the set value is stored even when the procedure is exited by waiting the time-out to expire.

HIDDEN MENU

The hidden menu includes all the parameters of the instrument.

HOW TO ENTER THE HIDDEN MENU

- Enter the Programming mode by pressing the **SET**+ keys for 3s ("°C" or "°F" LED starts blinking).
- Released the keys, then push again the **SET**+ keys for more than 7s. The L2 label will be displayed immediately followed from the Hy parameter.

NOW YOU ARE IN THE HIDDEN MENU.

- Select the required parameter.
- Press the "**SET**" key to display its value
- Use or to change its value.
- Press "**SET**" to store the new value and move to the following parameter.

To exit: Press **SET**+ or wait 15s without pressing a key.

NOTE1: if none parameter is present in L1, after 3s the "nP" message is displayed. Keep the keys pushed till the L2 message is displayed.

NOTE2: the set value is stored even when the procedure is exited by waiting the time-out to expire.

HOW TO MOVE A PARAMETER FROM THE HIDDEN MENU TO THE FIRST LEVEL AND VICEVERSA.

Each parameter present in the HIDDEN MENU can be removed or put into "THE FIRST LEVEL" (user level) by pressing **SET**+ . In HIDDEN MENU when a parameter is present in First Level the decimal point is on.

TO LOCK THE KEYBOARD

- Keep pressed for more than 3s the and keys.
- The "OF" message will be displayed and the keyboard will be locked. If a key is pressed more than 3s the "OF" message will be displayed.

TO UNLOCK THE KEYBOARD

Keep pressed together for more than 3s the and keys till the "on" message will be displayed.

7. PARAMETERS

REGULATION

B2: DIXELL OPERATING INSTRUCTIONS

dIXEL

Operating Manual

1592020130

- Hy Differential:** (0,1°C + 25°C) Intervention differential for set point. Compressor Cut IN is SET POINT + differential (Hy). Compressor Cut OUT is when the temperature reaches the set point.
- LS Minimum SET POINT:** (-55°C+SET/-58°F+SET): Sets the minimum value for the set point.
- US Maximum SET POINT:** (SET+99°C/ SET+99°F): Set the maximum value for set point.
- ot First probe calibration:** (-9.9+9.9°C) allows to adjust possible offset of the first probe.
- P2 Evaporator probe presence:** n= not present; y= the defrost stops by temperature. (Only XR04CX)
- oE Second probe calibration:** (-9.9+9.9°C) allows to adjust possible offset of the second probe. (Only XR04CX)
- od Outputs activation delay at start up:** (0+99min) This function is enabled at the initial start up of the instrument and inhibits any output activation for the period of time set in the parameter.
- AC Anti-short cycle delay:** (0+50 min) minimum interval between the compressor stop and the following restart.
- Cy Compressor ON time with faulty probe:** (0+99 min) time during which the compressor is active in case of faulty thermostat probe. With Cy=0 compressor is always OFF.
- Cn Compressor OFF time with faulty probe:** (0+99 min) time during which the compressor is OFF in case of faulty thermostat probe. With Cn=0 compressor is always active.
- CH Kind of Action (Only XR03CX):** cL= cooling action; Ht = heating action;

DISPLAY

- CF Measurement unit:** (°C+°F) °C=Celsius; °F=Fahrenheit. **WARNING:** When the measurement unit is changed the SET point and the values of the parameters Hy, LS, US, oE, ot, AU, AL have to be checked and modified if necessary.
- rE Resolution (only for °C):** (dE + in) dE= decimal between -9.9 and 9.9°C; in= integer
- Ld Default display:** (P1 + P2) P1= thermostat probe; P2= evaporator probe. SP=Set point (Only XR04CX)
- dy Display delay:** (0+15 min.) when the temperature increases, the display is updated of 1 °C/1°F after this time.

DEFROST

- td Defrost type:** (EL - in) EL= electrical heater, compressor OFF; in= hot gas, compressor ON;
- dE Defrost termination temperature (Only XR04CX):** (-50+50°C) if P2=Y it sets the temperature measured by the evaporator probe, which causes the end of defrost.
- id Interval between defrost cycles:** (0+99 ore) Determines the time interval between the beginning of two defrost cycles.
- Md Maximum length for defrost:** (0+99 min. with 0 no defrost) when P2=n, (not evaporator probe: timed defrost) it sets the defrost duration, when P2 = y (defrost end based on temperature) it sets the maximum length for defrost.
- dd Start defrost delay:** (0+99min) This is useful when different defrost start times are necessary to avoid overloading the plant.
- dF Display during defrost:** (rt / it / St / dF) rt= real temperature; it= start defrost temperature; SP= SET-POINT; dF= label dF.
- dt Drip time:** (0+99 min) time interval between reaching defrost termination temperature and the restoring of the control's normal operation. This time allows the evaporator to eliminate water drops that might have formed due to defrost.
- dP Defrost at power -on:** (y+n) y= at power on defrost starts; n= defrost doesn't start at power-on

ALARMS

- AU Maximum temperature alarm:** (AL+99°C) when this temperature is reached the alarm is enabled, after the "Ad" delay time.
- AL Minimum temperature alarm:** (-55+AU°C) when this temperature is reached the alarm is enabled, after the "Ad" delay time.
- Ad Temperature alarm delay:** (0+99 min) time interval between the detection of an alarm condition and alarm signalling.
- dA Exclusion of temperature alarm at startup:** (0+99 min) time interval between the detection of the temperature alarm condition after instrument power on and alarm signalling.
- tb Silencing buzzer (n-y):**(Only XR03CX) n= silencing disabled, alarm relay stays on till alarm conditions lasts; y= silencing enabled: alarm relay is switched OFF by pressing a key during an alarm;
- o1 Auxiliary relay configuration (dF/Fn/AL/AU/db):** (Only XR03CX) dF= defrost; Fn= Fans; AL= Alarm; AU= auxiliary; db= neutral zone;
- AP Alarm relay polarity (cL-OP):** (Only XR03CX) cL= when active is closed; OP= when active is opened

DIGITAL INPUT (Only XR03CX)

- iP Digital input polarity:** (oP + cL) oP= activated by closing the contact; cL= activated by opening the contact;
- iF Digital input configuration:** (EA/bA/do/dF/Au/Hc) EA= external alarm: "EA" message is displayed; bA= serious alarm "CA" message is displayed; do= door switch function; dF= defrost activation; Au =not used; Hc= inversion of the kind of action;
- di Digital input delay:** (0+99 min) with iF=EA or bA delay between the detection of the external alarm condition and its signalling. . With iF=do it represents the delay to activate the door open alarm.
- dC Compressor and fan status when open door:** (no/Fn/cP/Fc): no= normal; Fn = Fans OFF; cP =Compressor OFF; Fc = Compressor and fans OFF;
- rd Regulation with door open:** (n+y) n = no regulation if door is opened; Y= when di is elapsed regulation restarts even if door open alarm is present;

OTHER

- d1 Thermostat probe display (read only)**
- d2 Evaporator probe display (read only) (Only XR03CX)**
- Pt Parameter code table**
- rL Software release**

8. DIGITAL INPUTS

The free voltage digital input is programmable in different configurations by the "iF" parameter.

DOOR SWITCH (iF=do)

It signals the door status and the corresponding relay output status through the "dC" parameter: no = normal (any change); Fn = Fan OFF; cP = Compressor OFF; Fc = Compressor and fan OFF. Since the door is opened, after the delay time set through parameter "di", the door alarm is enabled, the display shows the message "dA" and the regulation restarts if rd = y. The alarm stops as soon

as the external digital input is disabled again. With the door open, the high and low temperature alarms are disabled.

EXTERNAL ALARM (iF=EA)

As soon as the digital input is activated the unit will wait for "di" time delay before signalling the "EA" alarm message. The outputs status don't change. The alarm stops just after the digital input is deactivated.

SERIOUS ALARM (iF=bA)

When the digital input is activated, the unit will wait for "di" delay before signalling the "CA" alarm message. The relay outputs are switched OFF. The alarm will stop as soon as the digital input is deactivated.

SWITCHING SECOND RELAY ON (iF=Au)

When o1=Au it switches on and off the second relay.

START DEFROST (iF=dF)

It starts a defrost if there are the right conditions. After the defrost is finished, the normal regulation will restart only if the digital input is disabled otherwise the instrument will wait until the "dd" safety time is expired.

INVERSION OF THE KIND OF ACTION: HEATING - COOLING (iF=Hc)

This function allows to invert the regulation of the controller: from cooling to heating and viceversa.

9. INSTALLATION AND MOUNTING

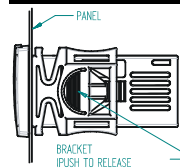

Instrument XR03CX and XR04CX shall be mounted on vertical panel, in a 29x71 mm hole, and fixed using the special bracket supplied.

The temperature range allowed for correct operation is 0-60 °C. Avoid places subject to strong vibrations, corrosive gases, excessive dirt or humidity. The same recommendations apply to probes. Let air circulate by the cooling holes.

10. ELECTRICAL CONNECTIONS

The instrument is provided with screw terminal block to connect cables with a cross section up to 2,5 mm². Before connecting cables make sure the power supply complies with the instrument's requirements. Separate the probe cables from the power supply cables, from the outputs and the power connections. Do not exceed the maximum current allowed on each relay, in case of heavier loads use a suitable external relay.

1.1 PROBES

The probes shall be mounted with the bulb upwards to prevent damages due to casual liquid infiltration. It is recommended to place the thermostat probe away from air streams to correctly measure the average room temperature. Place the defrost termination probe among the evaporator fins in the coldest place, where most ice is formed, far from heaters or from the warmest place during defrost, to prevent premature defrost termination.

11. HOW TO USE THE HOT KEY

1.2 HOW TO PROGRAM THE HOT KEY FROM THE INSTRUMENT (UPLOAD)

1. Program one controller with the front keypad.
2. When the controller is ON, insert the "Hot key" and push \triangle key; the "uP" message appears followed a by flashing "Ed"
3. Push "SET" key and the "Ed" will stop flashing.
4. Turn OFF the instrument remove the "Hot Key", then turn it ON again.

NOTE: the "Er" message is displayed for failed programming. In this case push again o key if you want to restart the upload again or remove the "Hot key" to abort the operation.

1.3 HOW TO PROGRAM AN INSTRUMENT USING HOT KEY (DOWNLOAD)

1. Turn OFF the instrument.
2. Insert a programmed "Hot Key" into the 5 PIN receptacle and then turn the Controller ON.
3. Automatically the parameter list of the "Hot Key" is downloaded into the Controller memory, the "do" message is blinking followed a by flashing "Ed".
4. After 10 seconds the instrument will restart working with the new parameters.
5. Remove the "Hot Key".

NOTE: the "Er" message is displayed for failed programming. In this case push again o key if you want to restart the upload again or remove the "Hot key" to abort the operation.

12. ALARM SIGNALLING

Mess.	Cause	Outputs
"P1"	Room probe failure	Compressor output according to "Cy" e "Cn"
"P2"	Evaporator probe failure	Defrost end is timed (Only XR04CX)
"HA"	Maximum temperature alarm	Outputs unchanged
"LA"	Minimum temperature alarm	Outputs unchanged
"EA"	External alarm	Outputs unchanged
"CA"	Serious external alarm	All outputs OFF.
"dA"	Door Open	Compressor and fans restarts

1.4 ALARM RECOVERY

Probe alarms "P1" and "P2" start some seconds after the fault in the related probe; they automatically stop some seconds after the probe restarts normal operation. Check connections before replacing the probe. Temperature alarms "HA" and "LA" automatically stop as soon as the temperature returns to normal values.

Alarms "EA" and "CA" (with iF=bA) recover as soon as the digital input is disabled.

13. TECHNICAL DATA

Housing: self extinguishing ABS.

Case: frontal 32x74 mm; depth 60mm;

Mounting: panel mounting in a 71x29mm panel cut-out

B3: DIXELL OPERATING INSTRUCTIONS

dIXEL

Operating Manual

1592020130

Protection: IP20; **Frontal protection:** IP65
Connections: Screw terminal block $\leq 2,5 \text{ mm}^2$ wiring.
Power supply: according to the model: 12Vac/dc, $\pm 10\%$; 24Vac/dc, $\pm 10\%$; 230Vac $\pm 10\%$, 50/60Hz, 110Vac $\pm 10\%$, 50/60Hz
Power absorption: 3VA max
Display: 2 digits, red LED, 14,2 mm high; **Inputs:** Up to 2 NTC or PTC probes.
Digital input: free voltage contact
Relay outputs: compressor SPST 8(3) A, 250Vac; or 20(8)A 250Vac defrost or Aux: SPDT 8(3) A, 250Vac
Data storing: on the non-volatile memory (EEPROM).
Kind of action: 1B; **Pollution grade:** 2; **Software class:** A;
Rated impulsive voltage: 2500V; **Overvoltage Category:** II
Operating temperature: 0+60 °C; **Storage temperature:** -30+85 °C.
Relative humidity: 20+85% (no condensing)
Measuring and regulation range: NTC probe: -40+110°C (-40+230°F);
Resolution: 0.1 °C or 1 °C or 1 °F (selectable); **Accuracy (ambient temp. 25°C):** $\pm 0,7 \text{ °C} \pm 1 \text{ digit}$

14. CONNECTIONS

XR03CX -20A o 8A Compressor

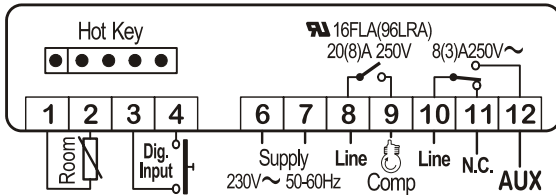

NOTE: The compressor relay is 20(8)A or 16(6)A depending on the model.
 NOTE: 120Vac or 24Vac/dc or 12Vac/dc connect to 6-7

XR04CX -20A o 8A Compressor

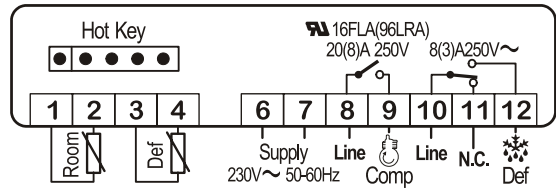

NOTE: The compressor relay is 20(8)A or 16(6)A depending on the model.
 NOTE: 120Vac or 24Vac/dc or 12Vac/dc connect to 6 and 7

15. DEFAULT SETTING VALUES

LAB EL	DESCRIPTION	RANGE	DEFAULT
REGULATION			
Hy	Differential	0.1 + 25°C/1 + 45°F	2.0°C / 4 °F
LS	Minimum Set Point	-55°C+SET/-67°F+SET	-55 °C / -55°F
US	Maximum Set Point	SET+99°C/ SET+210°F	99 °C / 99°F
ot	First probe calibration	-9.9+9.9°C/-18+18°F	0.0
P2	Second probe presence (Only XR04CX)	n - Y	y
oE	Second probe calibration (Only XR04CX)	-9.9+9.9°C/-18+18°F	0.0
od	Outputs activation delay at start up	0 + 99 min	0
AC	Anti-short cycle delay	0 + 50 min	1
Cy	Compressor ON time faulty probe	0 + 99 min	15
Cn	Compressor OFF time faulty probe	0 + 99 min	30
CH	Kind of Action (Only XR03CX)	cL + Ht	cL
DISPLAY			
CF	Measurement units	°C - °F	°C / °F
rE	Resolution (only for °C)	dE - in	dE
Ld	Default Display (Only XR04CX)	P1-P2 - SP	P1
dy	Display delay	0 + 15 min	0
DEFROST			
td	Defrost type	EL - in	EL
dE	Defrost termination temperature	-50+50°C/-58+122°F	8.0 °C / 46 °F
id	Interval between defrost cycles	0 + 99 hours	6
Md	Maximum length for defrost	0 + 99 min.	30

dd	Start defrost delay	0 + 99 min.	0
dF	Display during defrost	rt - in - SP - dF	it
dt	Drip time	0 + 99 min	0
dP	Defrost at power-on	y - n	n

ALARMS			
AU	Maximum temperature alarm	ALL+99°C / ALL+210°F	99 °C / 99 °F
AL	Minimum temperature alarm	-55°C+ALU/-67°F+ALU	-55 °C / -55 °F
Ad	Temperature alarm delay	0 + 99 min	15
dA	Exclusion of temperature alarm at startup	0 + 99 min	90

DIGITAL INPUT (Only XR03CX)			
IP	Digital input polarity	cL - oP	cL
IF	Digital input configuration	EA - bA - do - dF - Au - db	EA
di	Digital input delay	0 + 99 min	5
dC	Compressor and fan status when open door	no /Fn / cP / Fc	FC
rd	Regulation with door open	n - Y	y

OTHER			
d1	Thermostat probe display	Read Only	---
d2	Evaporator probe display	Read Only	---
Pt	Parameter code table	Read Only	---
rL	Firmware release	Read Only	---

dIXEL S.p.a.

Z.I. Via dell'Industria, 27 - 32010 Pieve d'Alpago (BL) ITALY
 tel. +39 - 0437 - 98 33 - fax +39 - 0437 - 98 93 13
<http://www.dixell.com> E-mail: dixell@dixell.com

C1: SPORLAN PRESSURE-TEMPERATURE CHART



Vacuum-Inches of Mercury
Bold Italic Figures

TEMPERATURE PRESSURE CHART - at sea level

Pressure-Pounds Per
Square Inch Gauge

TEMPERATURE (°F)	REFRIGERANT (SPORLAN CODE)			TEMPERATURE			REFRIGERANT (SPORLAN CODE)			TEMPERATURE							
	134a (J)	404A (S)	507 (P)	(°F)	(°C)	(°F)	134a (J)	404A (S)	507 (P)	(°F)	(°C)	(°F)					
-60	51.1	21.8	7.3	5.8	18.6	79.9	13.1	45.4	48.1	25.6	357.4	5.6	37.0	88.8	92.8	61.6	569.3
-55	48.3	20.3	3.9	2.2	16.6	91.1	13.8	46.6	49.3	26.5	363.4	43	38.0	90.6	94.6	63.1	577.6
-50	45.6	18.7	0.1	0.9	14.3	103.4	14.4	47.8	50.5	27.5	369.5	44	39.0	92.4	96.5	64.7	586.0
-45	42.8	16.9	2.0	3.0	11.7	116.6	15.0	49.0	51.8	28.4	375.6	45	40.1	94.2	98.3	66.3	594.5
-40	40.0	14.8	4.3	5.4	8.8	131.0	15.7	50.2	53.0	29.4	381.8	46	41.1	96.0	100.2	67.9	603.1
-35	37.2	12.5	6.8	8.1	5.4	146.5	16.4	51.5	54.3	30.4	388.0	47	42.2	97.9	102.1	69.5	611.7
-30	34.4	9.8	9.6	11.0	1.6	163.1	17.0	52.7	55.6	31.4	394.3	48	43.2	99.8	104.1	71.1	620.5
-25	31.7	6.9	12.7	14.1	1.3	181.0	17.7	54.0	56.9	32.4	400.7	49	44.3	101.7	106.0	72.8	629.3
-20	28.9	3.7	16.0	17.6	3.6	200.2	18.4	55.3	58.3	33.5	407.2	50	45.4	103.6	108.0	74.5	638.3
-18	27.8	2.3	17.4	19.1	4.6	208.3	19.1	56.6	59.6	34.6	413.8	55	46.5	105.5	110.3	76.8	647.4
-16	26.7	0.8	18.9	20.6	5.6	216.5	19.9	58.0	61.0	35.7	420.4	60	47.6	107.6	112.6	79.1	656.5
-14	25.6	0.4	20.4	22.2	6.7	225.0	20.6	59.3	62.4	36.8	427.1	65	48.7	109.9	114.9	81.4	665.6
-12	24.4	1.1	22.0	23.8	7.8	233.8	21.3	60.7	63.8	37.9	433.8	70	49.8	112.2	117.2	83.7	674.7
-10	23.3	1.9	23.6	25.5	9.0	242.7	22.1	62.1	65.3	39.0	440.7	75	50.9	114.5	119.5	86.0	683.8
-8	22.2	2.8	25.3	27.3	10.3	251.9	22.9	63.5	66.7	40.2	447.6	80	52.0	116.8	121.8	88.3	692.9
-6	21.1	3.6	27.0	29.1	11.5	261.3	23.7	64.9	68.2	41.4	454.6	85	53.1	119.1	124.1	90.6	702.0
-4	20.0	4.6	28.8	30.9	12.9	271.0	24.5	66.4	69.7	42.6	461.7	90	54.2	121.4	126.4	92.9	711.1
-2	18.9	5.5	30.7	32.8	14.3	280.9	25.3	67.8	71.2	43.8	468.8	95	55.3	123.7	128.7	95.2	720.2
0	17.8	6.5	32.6	34.8	15.7	291.0	26.1	69.3	72.7	45.0	476.1	100	56.4	126.0	131.0	97.5	729.3
1	17.2	7.0	33.6	35.8	16.4	296.2	26.9	70.8	74.3	46.3	483.4	105	57.5	128.3	133.3	100.0	738.4
2	16.7	7.5	34.6	36.9	17.2	301.5	27.8	72.4	75.9	47.6	490.8	110	58.6	130.6	135.6	102.5	747.5
3	16.1	8.0	35.6	37.9	18.0	306.8	28.6	73.9	77.5	48.9	498.3	115	59.7	132.9	137.9	105.0	756.6
4	15.6	8.5	36.6	39.0	18.8	312.1	29.5	75.5	79.1	50.2	505.8	120	60.8	135.2	140.2	107.5	765.7
5	15.0	9.1	37.7	40.1	19.6	317.6	30.4	77.1	80.7	51.6	513.4	125	61.9	137.5	142.5	110.0	774.8
6	14.4	9.6	38.7	41.1	20.4	323.1	31.3	78.7	82.4	52.9	521.2	130	63.0	139.8	144.8	112.5	783.9
7	13.9	10.2	39.8	42.3	21.2	328.6	32.2	80.3	84.1	54.3	529.0	135	64.1	142.1	147.1	115.0	793.0
8	13.3	10.8	40.9	43.4	22.1	334.2	33.1	82.0	85.8	55.7	536.9	140	65.2	144.4	149.4	117.5	802.1
9	12.8	11.3	42.0	44.5	22.9	339.9	34.1	83.7	87.5	57.2	544.8	145	66.3	146.7	151.7	120.0	811.2
10	12.2	11.9	43.1	45.7	23.8	345.7	35.0	85.4	89.2	58.6	552.9	150	67.4	149.0	154.0	122.5	820.3
11	11.7	12.5	44.3	46.9	24.7	351.5	36.0	87.1	91.0	60.1	561.0	155	68.5	151.3	156.3	125.0	829.4

To determine subcooling for R-404A use BUBBLE POINT values (Temperatures above 50°F — Gray Background); to determine superheat for R-404A, use DEW POINT values (Temperatures 50°F and below).
** = exceeds critical temperature

D1: PARTS LIST

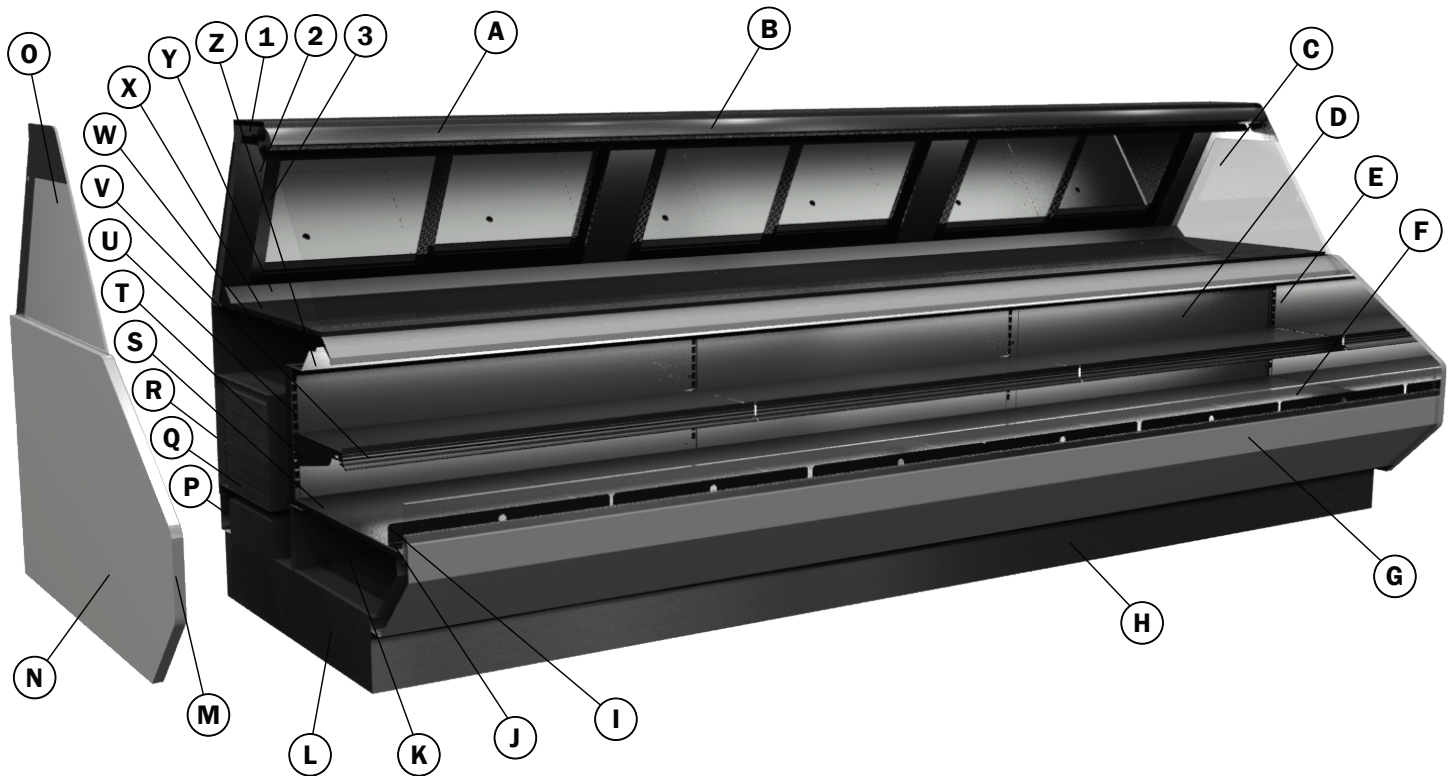

A	Lift Glass Hardware	1	Dome Strut
B	Case Top	2	Dome Inside Back
C	Front Lift Glass	3	Dome Sliding Rear Load Doors
D	Base Inside Back		
E	Interior End Panel		
F	Die Board Plex		
G	Die Board		
H	Front Toekick		
I	Base Product Stop		
J	Base Air Return		
K	Base Insulated Drain Pan		
L	End Toe Kick		
M	End Panel Trim		
N	End Panel		
O	Fixed End Glass		
P	Electrical Raceway		
Q	Lower Rear Storage		
R	Outside Back		
S	Base Bottom Deck		
T	Adjustable Shelf Bracket		
U	Shelf Standard		
V	Price Tag Molding		
W	Dome Insulated Drain Pan		
X	Dome Bottom Deck		
Y	Dome Air Discharge		
Z	Base Air Discharge		



A DOVER COMPANY

Hill PHOENIX, Inc.
Hereinafter Referred To As Manufacturer

LIMITED WARRANTY

GENERAL WARRANTY

Manufacturer's products are warranted to be free from defects in materials and workmanship under normal use and maintenance for fourteen months from date of shipment from manufacturer (the "Base Warranty Period"). In the event of a qualifying warranty claim, a new or rebuilt part to replace any defective part will be provided without charge. The replacement part is covered under this warranty for the remainder of the applicable Base Warranty Period. In order to be eligible for warranty coverage, customer must: (i) notify Manufacturer promptly upon discovery of a warrant defect, and (ii) comply with the warranty claim procedures provided by Manufacturer from time to time.

This equipment warranty does not include labor or other costs incurred for diagnosing, repairing, removing, installing, shipping, servicing, or handling of either defective parts or replacement parts.

The warranty shall not apply:

1. To any unit or any part thereof which has been subject to accident, alteration, negligence, misuse or abuse, or which has not been operated in accordance with the manufacturer's recommendations, or in conditions outside of Manufacturer's specifications, or if the serial number of the unit has been altered, defaced, or removed.
2. When the unit, or any part thereof, is damaged by fire, flood, or other act of God.
3. To products that are impaired or damaged due to improper installation.
4. When installation and startup forms are not properly completed or returned within two weeks after startup.
5. If the defective part is not returned to the Manufacturer.
6. To service, maintenance or wear and tear parts (such as lights, starters and ballasts)

MODIFICATIONS TO GENERAL WARRANTY

The following sets forth certain modifications to the General Warranty for specific products of Manufacturer:

DISPLAY CASE AND SPECIALTY PRODUCTS CLEARVOYANT® LED LIGHTING

The warranty period for Clearvoyant LED lighting components within the Clearvoyant lighting system is five years from date of shipment.

REMEDY LIMITATION/DAMAGES EXCLUSION

THE REMEDY OF REPAIR OR PROVISION OF A REPLACEMENT PART WITHOUT CHARGE SHALL BE THE EXCLUSIVE REMEDY FOR ANY WARRANTY CLAIM HEREUNDER. WITHOUT LIMITING THE FOREGOING, MANUFACTURER SHALL NOT BE LIABLE UNDER ANY CIRCUMSTANCES FOR INCIDENTAL, INDIRECT OR CONSEQUENTIAL DAMAGES, INCLUDING LOSS OF PROFIT, LABOR COST, LOSS OF REFRIGERANT OR FOOD PRODUCTS.

EXCLUSIVE WARRANTY

THE FOREGOING WARRANTY IS THE EXCLUSIVE WARRANTY WITH RESPECT TO THE PRODUCTS. ALL OTHER WARRANTIES, WHETHER EXPRESS OR IMPLIED, INCLUDING WITHOUT LIMITATION, THE WARRANTIES OF MERCHANTABILITY OR FITNESS FOR A PARTICULAR PURPOSE, ARE HEREBY DISCLAIMED AND EXCLUDED. NO IMPLIED WARRANTY SHALL BE DEEMED CREATED BY COURSE OF DEALING OR USAGE OF TRADE. NO OTHER PERSON IS AUTHORIZED TO EXPAND OR CREATE ANY OBLIGATION GREATER THAN OR MORE EXPANSIVE THAN THE WARRANTY PROVIDED HEREIN.

Submit warranty claims to:

Hillphoenix Refrigeration & Power

Systems Division
2016 Gees Mill Road
Conyers, GA 30013
Warranty / Service
Phone: 1-833-280-5714

Hillphoenix Display Case Division

1925 Ruffin Mill Road
Colonial Heights, VA 23834
Warranty / Service
Phone: 1-833-280-5714

Hillphoenix Specialty Products Division

703 Franklin Street
Keosauqua, IA 52565
Warranty / Service
Phone: 1-833-280-5714

Warning **Maintenance & Case Care**

When cleaning cases the following must be performed PRIOR to cleaning:

To avoid electrical shock, be sure all electric power is turned off before cleaning. In some installations, more than one switch may have to be turned off to completely de-energize the case.

Do not spray cleaning solution or water directly on fan motors or any electrical connections.

All lighting receptacles must be dried off prior to insertion and re-energizing the lighting circuit.

Please refer to the Use and Maintenance section of this installation manual.

Hillphoenix[®]

a **DOVER** company

Hillphoenix Specialty Products

1-319-293-3777

703 Franklin Street, PO Box 478, Keosauqua, IA 52565

Due to our commitment to continuous improvement, all specifications are subject to change without notice.

Hillphoenix is a Sustaining Member of the American Society of Quality.

Visit our website at www.hillphoenix.com

