

# HANDBOOK

## INSTALLATION & OPERATION

# O3EIF

## MEAT CASES

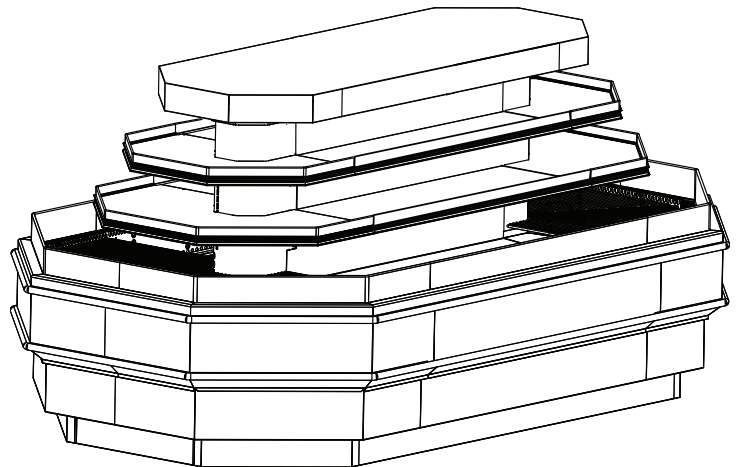

### Table of Contents

General Information .....	2
Using Casters .....	3
Case Dimensions.....	4
Case Operations.....	5
Line Up & Trim Out .....	6
Piping: Refrigeration & Plumbing.....	7
Electrical Hook-Up .....	8
Wiring Diagrams .....	9
Defrost & Temperature Control .....	10
Air Flow & Product Loading.....	11
Use & Maintenance .....	12-13
Parts Ordering .....	14-15



## **DANGER**

Be certain that hands and feet are out of the way before lowering the case after the removal of the outriggers. Failure to do so may result in serious injury.



## **DANGER**

**ELECTRICAL SHOCK HAZARD**  
Always disconnect power to case when servicing or cleaning.

# GENERAL INFORMATION

Welcome to the Hill PHOENIX display case family. We're very pleased that you've chosen Hill PHOENIX for your food merchandising needs. This handbook is targeted to individuals involved in the installation and/or operation of display cases and contains detailed illustrations and important information about the product. By closely following the manual's instructions, you can expect peak performance, attractive fits and finish, and long case life from the product.

We are always interested in your suggestions for improvements (e.g. case design, technical documents, etc.), so please feel free to contact Marketing Services at the toll-free number listed below. Thank you for choosing Hill PHOENIX, and we wish you the very best in outstanding food merchandising.

---

## Description of Cases

Specifically covered in this manual is the O3EIF meat merchandise.

## Store Conditions

Hill PHOENIX cases are designed to operate in an air-conditioned store that maintains a 75°F (24°C) store temperature and 55% (max) relative humidity (CRMA conditions). Case operation will be adversely affected by exposure to excessively high ambient temperatures and/or humidity.

## Refrigeration System Operation

Air-cooled condensing units require ventilation for the efficient performance of condensers. Machine-room temperatures must be a minimum of 65°F in winter and a maximum of 95°F in summer. Minimum condensing temperatures should be no less than 70°F.

## Receiving Cases

Examine fixtures carefully for shipping damage and shortages. For information on shortages, contact the Service Parts Department at the toll-free number listed below.

## Apparent Damage

Claims for obvious damage must be 1) noted on either the freight bill or the express receipt and 2) signed by the carrier's agent; otherwise, the carrier may refuse the claim.

## Concealed Damage

If damage becomes apparent after the equipment is unpacked, retain all packing materials and submit a written request to the carrier for inspection within 15 days of receipt of the equipment.

## Lost Items

Equipment has been carefully inspected to insure the highest level of quality. Any claim for lost items must be made to Hill PHOENIX within 48 hours of receipt of the equipment.

## Technical Support

For technical questions regarding display cases, please contact our Case Division Customer Service Department at the toll-free number listed below. For questions regarding our refrigeration systems or electrical distribution centers, please contact our Systems Division Customer Service Department at 1-770-388-0706.

## Contacting the Factory

If you need to contact Hill PHOENIX regarding a specific fixture, be certain that you have both the case model number and serial number - this information is on the serial plate located on the lower rear baffle of the case (see next page for details). When you have this information, call the toll-free number below and ask for a Service Parts Representative.

**Hill Phoenix**  
**1925 Ruffin Mill Rd.**  
**Colonial Heights, VA 23834**  
**Tel: 1-800-283-1109**  
**Fax: 804-526-7450**  
**Web site: [www.hillphoenix.com](http://www.hillphoenix.com)**

# USING CASTERS

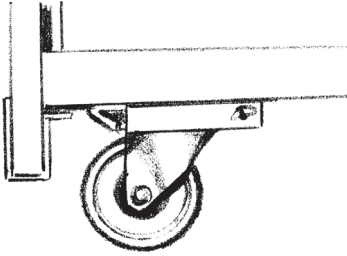

Cases are shipped to stores with casters installed on the base frame. Casters make moving cases easier and reduce the risk of damage caused by raising and lowering cases with a "J" bar when placing them on dollies, skates, or rollers.

In most situations, one or two persons can move the cases with ease; however, a minimum of two persons will be required to remove the casters in order to complete final installation.

## Step 1

If there is a truck-level delivery dock, cases may be rolled directly from the truck to the store floor. Prior to final installation, casters may remain in place to help move the cases to staging areas throughout the store. When you're ready for final line-up, roll the cases to the set position before removing the casters.

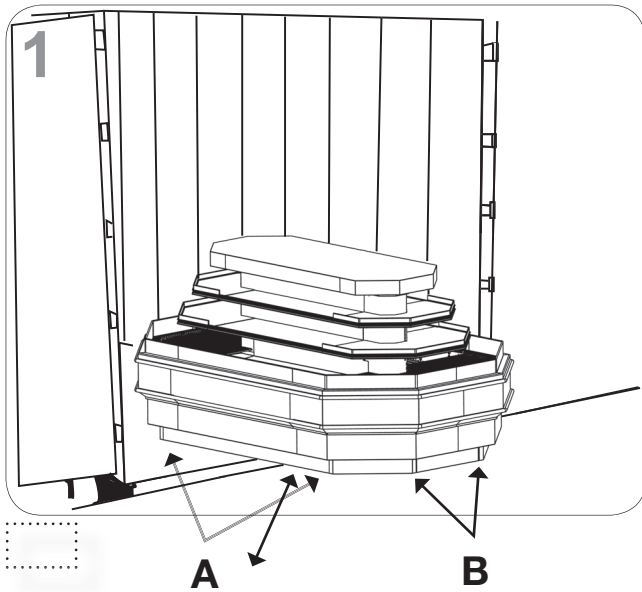

**IMPORTANT:** If skid boards are required for unloading cases, casters should be removed prior to sliding cases down the skid (see Diagram 3). When unloading is complete, re-install the casters.



## **DANGER**

Be certain that hands and feet are out of the way before lowering the case after the removal of the casters. Failure to do so may result in serious injury.

## Step 2

Casters are located beneath the case, on both sides and both ends (see diagrams 1 and 3 for relative positions). To remove the casters, lift the case with "J" bar, then remove the cotter pins (see diagram 4). The casters should simply fall off and are ready to be discarded.

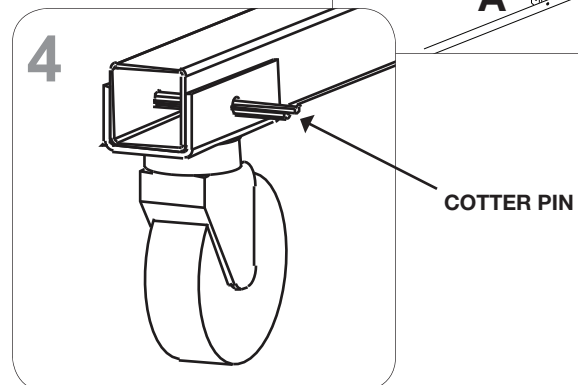
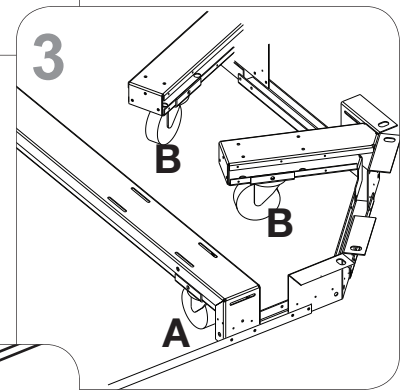
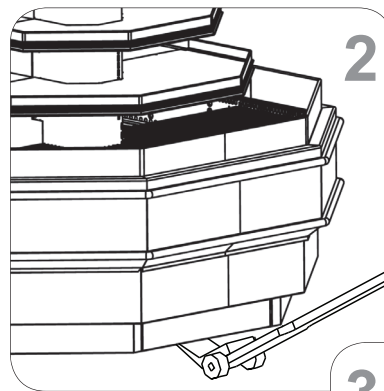

**NOTE:** Casters should be discarded when installation is complete.

# CASE DIMENSIONS

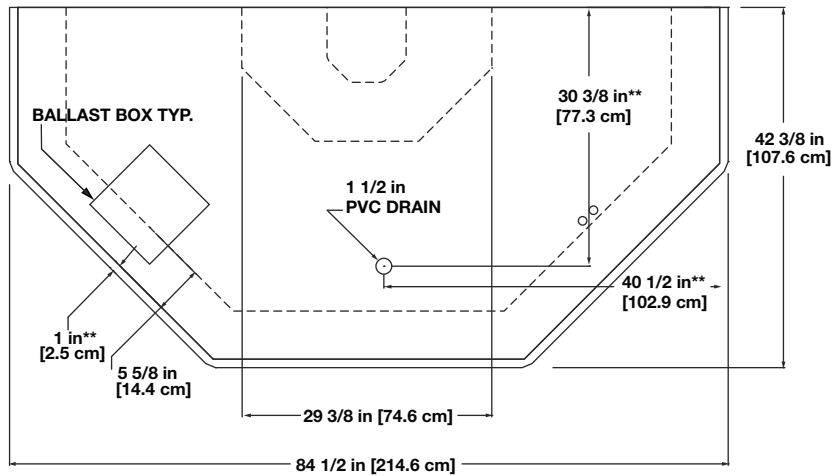
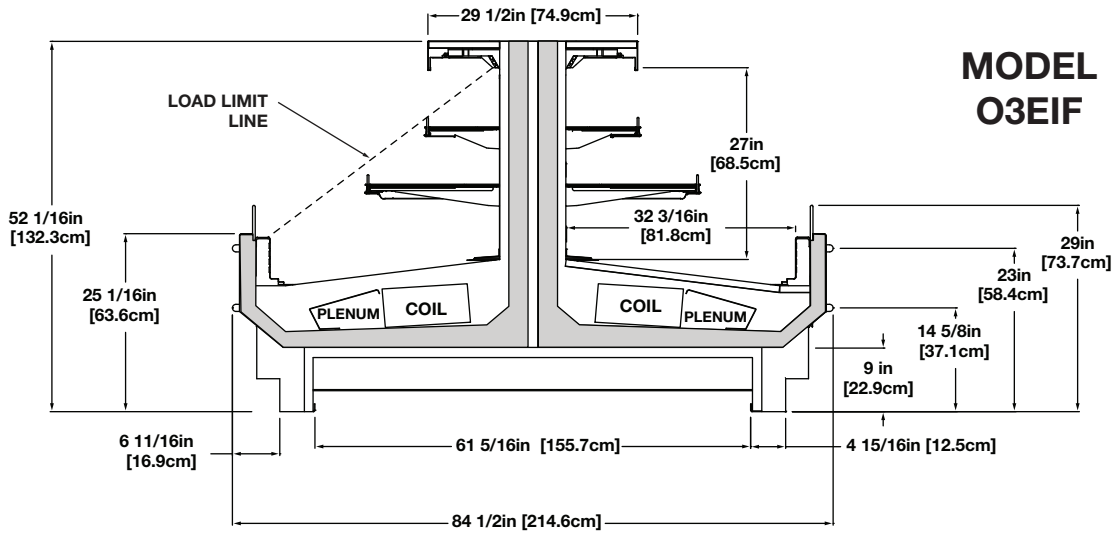

**NOTES:**

\* STUB-UP AREA

\*\* RECOMMENDED STUB-UP CENTERLINE FOR ELECTRICAL AND HUB DRAINS

- FRONT SILL HEIGHT AND OVERALL CASE HEIGHT VARIES WITH BASEFRAME HEIGHT
- REFER TO O3UM FOR SUCTION AND LIQUID LINE SIZES
- SHELF SIZES BASED ON O3UM SHELF SLECTION
- DASHED LINES SIGNIFY AREA INSIDE BASE RAIL BEHIND KICK-PLATE

# CASE OPERATION

## Electrical Data

Model	Fans per Case	High Efficiency Fans		Anti-Condensate Heaters		Defrost Heaters			
		120 Volts		120 Volts		208 Volts		240 Volts	
		Amps	Watts	Amps	Watts	Amps	Watts	Amps	Watts
O3EIF	2	0.3	21	---	---	---	---	---	---

<sup>2</sup> NOTE: "---" not an option on this case model.

## Defrost Controls

Model	Defrosts Per Day	Run-Off Time (min)	Electric Defrost		Timed Off Defrost		Reverse Air Defrost	
			Fail-Safe (min)	Termination Temp (°F)	Fail-Safe (min)	Termination Temp (°F)	Fail-Safe (min)	Termination Temp (°F)
O3EIF	4	0	---	---	40	47	---	---

## Lighting Data

Model	Bulbs per Row	Bulb Length	Typical per Light Row		Maximum Lighting	
			120 Volts		120 Volts	
			Amps	Watts	Amps	Watts
O3EIF	3	12"	0.15	16	0.71	72

## Guidelines & Control Settings

Model	BTUH/cs <sup>2</sup>	Coil Type	Evaporator (°F)	Superheat Set Point @ Bulb (°F)	Discharge Air (°F)	Return Air (°F)	Discharge Air Velocity <sup>3</sup> (FPM)
O3EIF	2600	Enh.	22	6-8	30	40	235

<sup>2</sup> BTUHs/case listed are for parallel operation. Conventional ratings may be approximated by multiplying listed rating by 1.04.

<sup>3</sup> Average discharge air velocity at peak of defrost.

All measurements are taken per CRMA specifications.

# LINE UP & TRIM OUT

Ask the general contractor if there have been any changes to the building's dimensions since the blueprint you are using was issued. Also, ask the points of reference from which you should take dimensions to locate the cases.

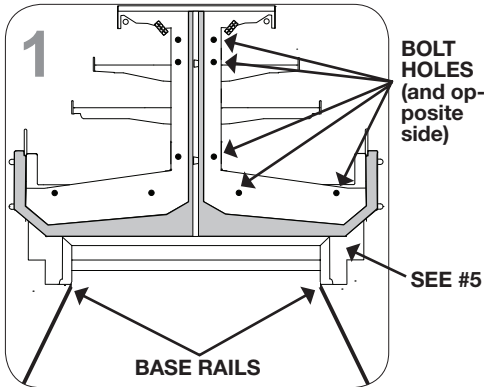

## Step 1

Using chalk lines, mark the floor where cases are to be located for the entire lineup. Snap lines where the base rails are positioned — not the front or back edges of the cases.

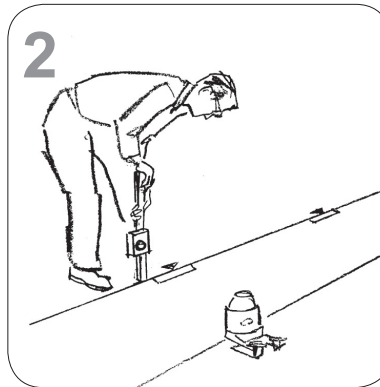

## Step 2

Locate the highest point on the chalk line as a reference for determining the height of shim-pack levelers. A laser transit is recommended for precision and requires just one person.

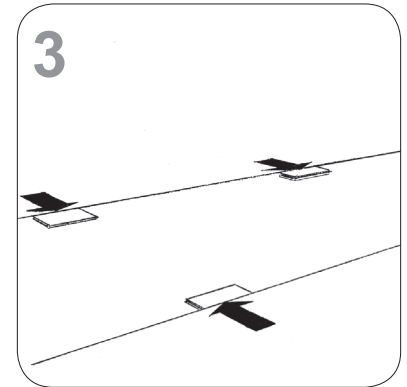

## Step 3

Locate basehorse positions along chalk lines. Spot shim packs at each basehorse location.

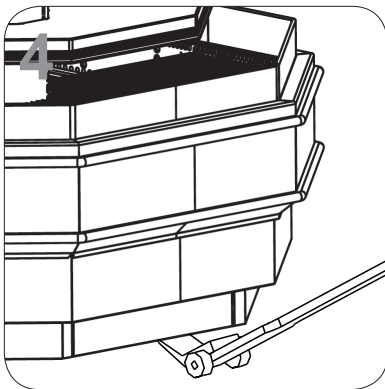

## Step 4

Roll the case components into position. Raise components from the end under cross support using "J" bar. Remove cotter pins and casters. **REMEMBER TO KEEP YOUR HANDS AWAY FROM THE BOTTOM OF THE CASE!** Level the case on shims.

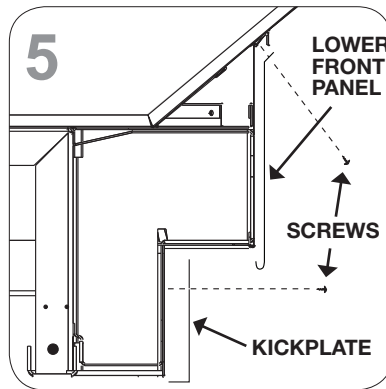

## Step 5

Position the case components for final assembly, then bolt the cases together (use bolt holes shown in diagram 1). Tighten until all margins are equal. **DO NOT OVERTIGHTEN.** Then, using the screws provided, attach the lower-front panel and the kickplate.

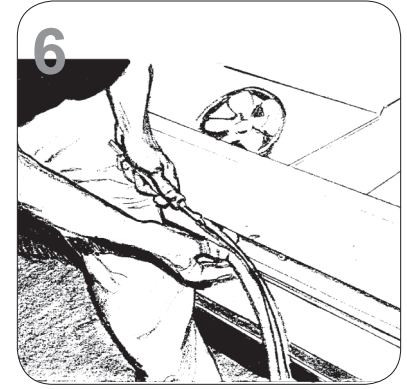

## Step 6

Insert nose bumper into master bumper channel. Roll nose bumper into channel along entire lineup. We recommend that the nose bumper be left in the store 24 hours before installing. **DO NOT STRETCH** the bumper during installation as it will shrink to its original length and leave a gap.

# PIPING

## REFRIGERATION

Refrigeration components and the coil outlet hole are located to provide the best access for installation and maintenance of a the unitized unit.

The expansion valve and other controls are located on the left-hand side of each case and are accessible without lifting the fan plenum. The controls cluster may be reached by lifting only the left hand deck pan minimizing the need to unload product.

If it becomes necessary to penetrate the case bottom for any reason, make certain it is sealed with canned-foam sealant and white RTV.

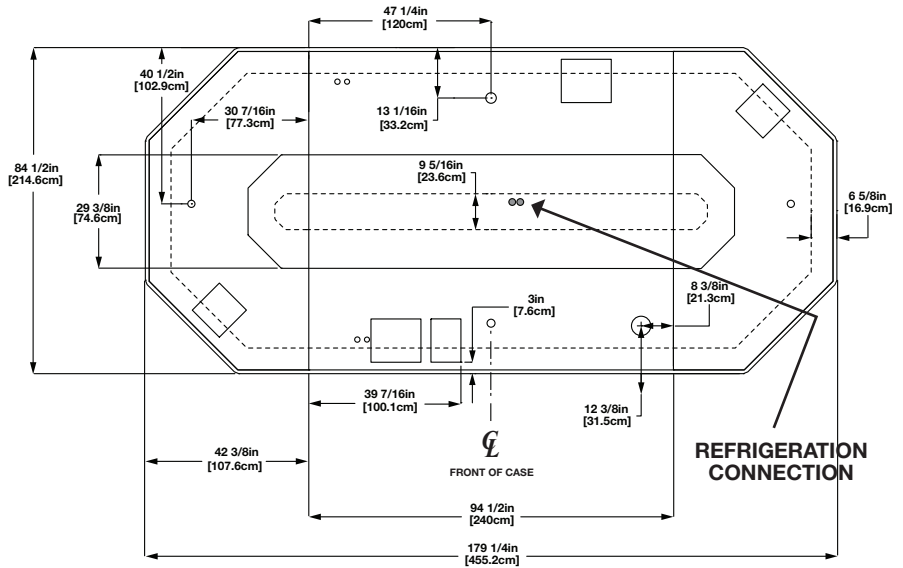

## 1 1/2" PVC DRAIN CONNECTION

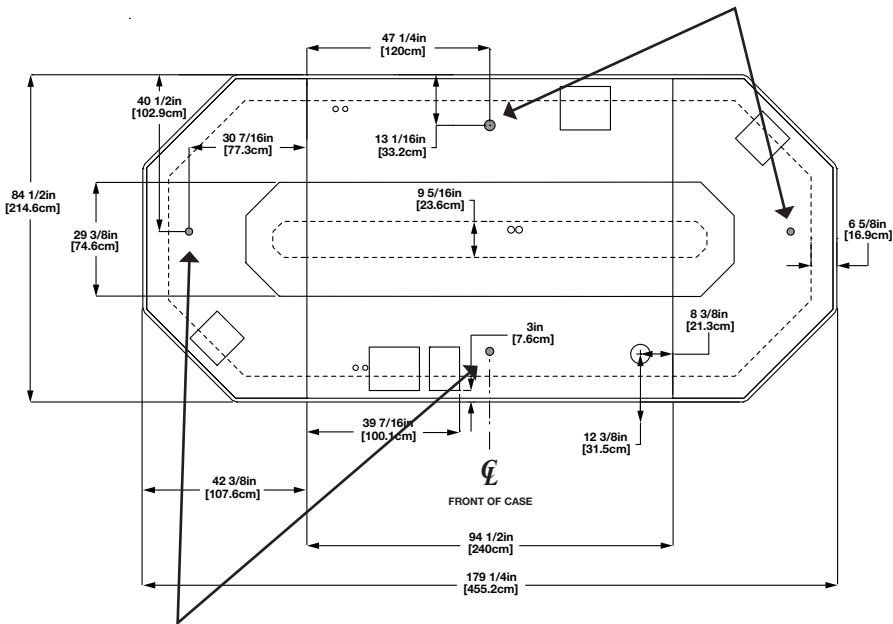

## 1 1/2" PVC DRAIN CONNECTION

## PLUMBING

Drain outlets are located front and center of each of the cases for convenient access and is especially molded out of ABS material. The "P" trap, furnished with the case, is constructed of schedule 40 PVC pipe.

Care should be given to assure that all connections are water tight and sealed with the appropriate PVC or ABS cement.

The outlet is positioned to allow 180° swing of the trap. The lines can be run left or right of the tee with the proper pitch to satisfy local drainage requirements.

The kickplate is shipped loose with the case for field installation; therefore, you should have open access to the drain line area.

If the kickplate has been installed, you will find it easy to remove. See the trim out section of this manual on page 6.



# ELECTRICAL HOOKUP

Electrical hookups for the unitized O3EIF are made to a single-point connection box, which is located at the bottom of the case, just left of the center line (see diagram below).

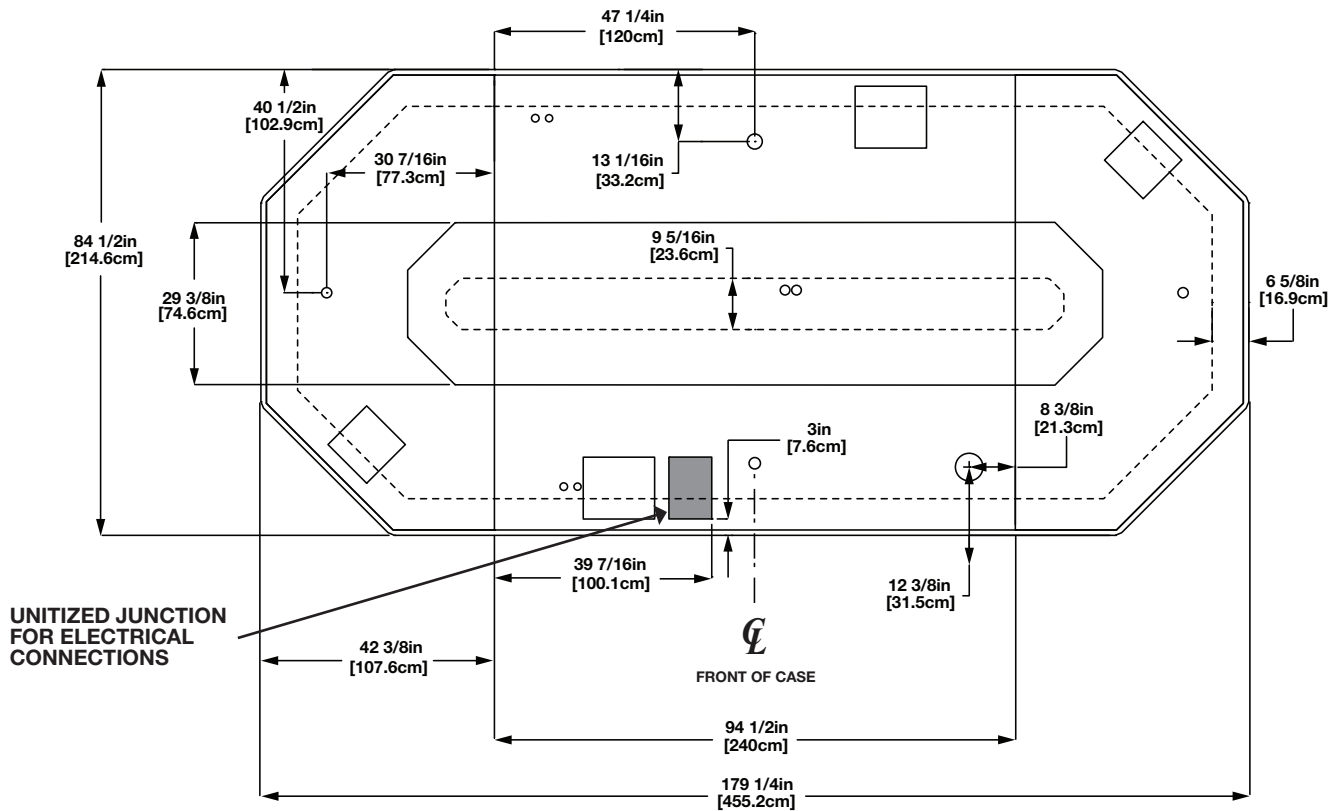

## WIRING NUMBERS & COLORS

COMPONENT	WIRE NUMBER	COLOR CODING
EVAPORATOR FANS (120V)	3	WHITE
	4	BLACK
LIGHTS (120V)	11	WHITE
	12	BLACK
ANTI-CONDENSATE HEATERS (120V)	13	WHITE
	14	BLACK
TEMPERATURE CONTROL (120V)	19	YELLOW
	20	YELLOW
DEFROST TERMINATION CONTROL (120V)	21	PURPLE
	23	ORANGE
DEFROST HEATERS (208/240V)	L1	BLACK
	L2	RED
EQUIPMENT GROUNDING CONDUCTOR	-	GREEN

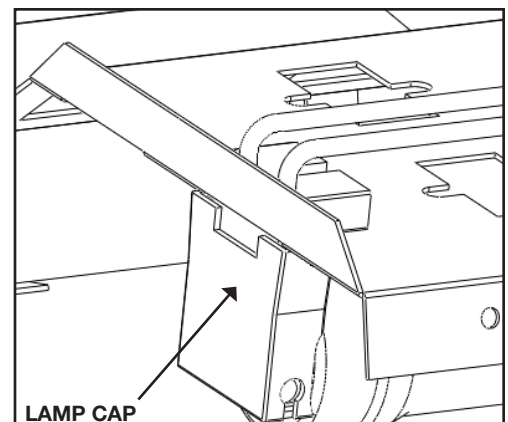

**NOTE:** When installing any lamp (cornice, shelf, nose, etc.), be certain that the lamp cap is seated firmly in the lamp holder.

# WIRING DIAGRAMS

**MODEL  
O3EIF**

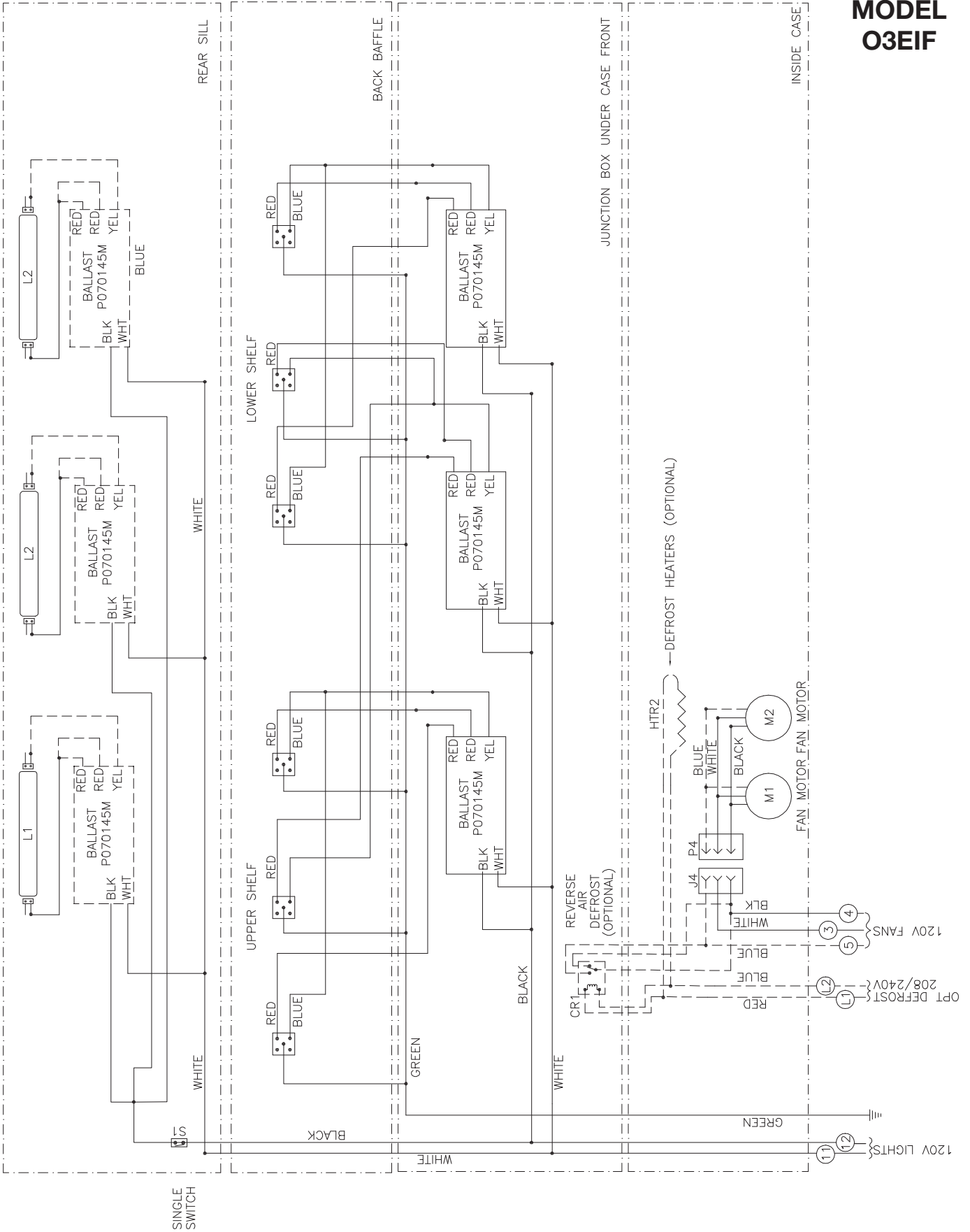

# DEFROST & TEMP CONTROL

These cases are equipped with either Electric, Hot Gas, or Timed Off defrost at the owners option. The sensor bulb and probe for electric defrost termination, timed off defrost termination, and temperature control are all located behind the rear baffle (see diagram 1). The discharge air probe is located behind the discharge honeycomb (see diagram 1).

The hot gas defrost termination sensor bulb and probe are attached to the dump line, which is located in the front, left-hand side of the case (see diagram 2 below).

The defrost termination control thermostat and the temperature control thermostat are located in the ballast box underneath the case on the bottom left side (see diagram 3 below).

To access the thermostats, you must first remove the kickplate and lower front-panel; then slide out the ballast box. For instruction on removing the kickplate and lower front panel, see the Trim Out section of this manual on page 6.

It is important to consult the control setting guidelines shown on page 5 before setting defrost times. Further adjustments may be required depending on store conditions.

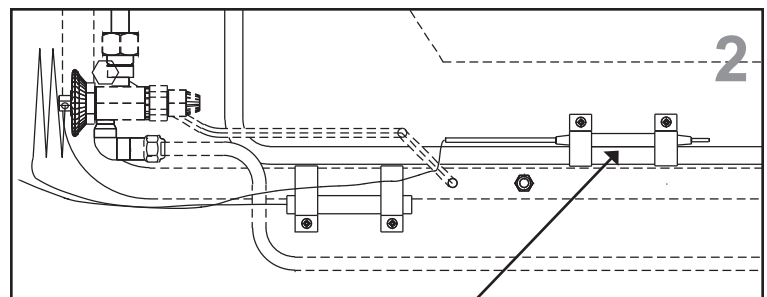
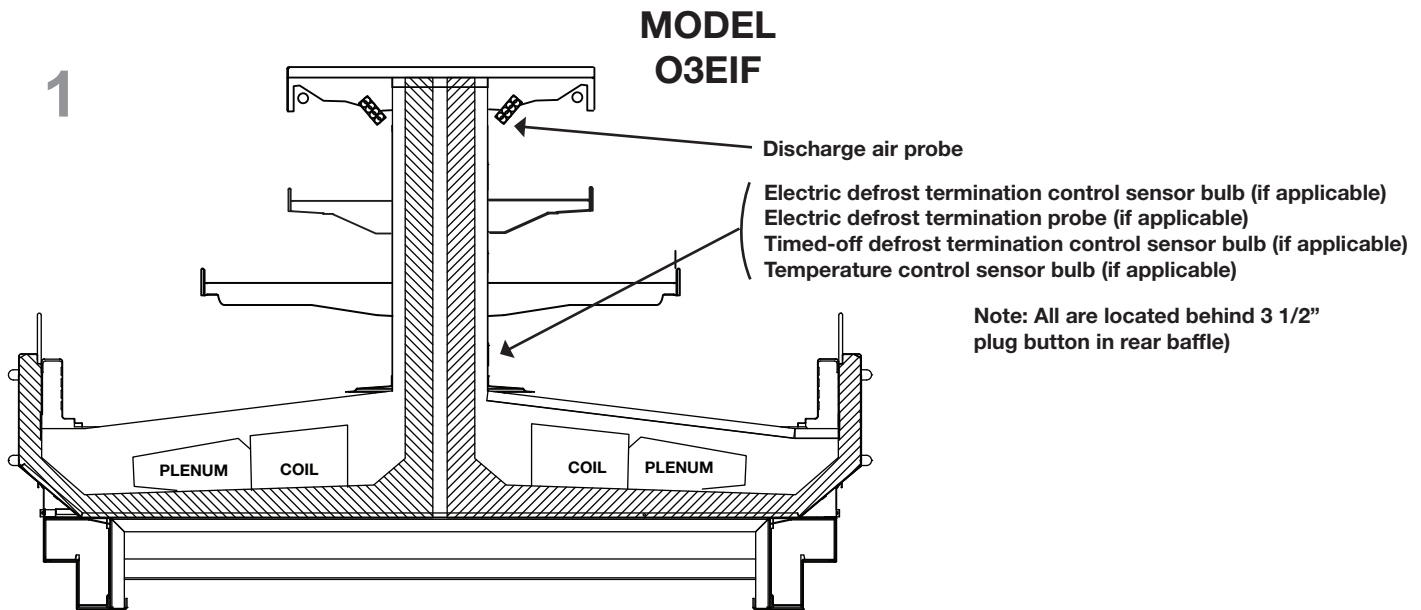

Hot gas defrost termination control sensor bulb and probe location

# AIR FLOW & PRODUCT LOADING

Cases have been designed to provide maximum product capacity within the refrigerated air envelope. It is important that you do not overload the food product display so that it impinges on the air flow pattern.

Overloading the case will result in malfunction and the loss of proper temperature levels, particularly when discharge and return air sections are covered.

Please keep products within the load-limit lines shown in the diagram.

**DISCHARGE ..... 1**

**LOAD LIMIT..... 2**

**AIR FLOW ..... 3**

**RETURN AIR GRILL ..... 4**

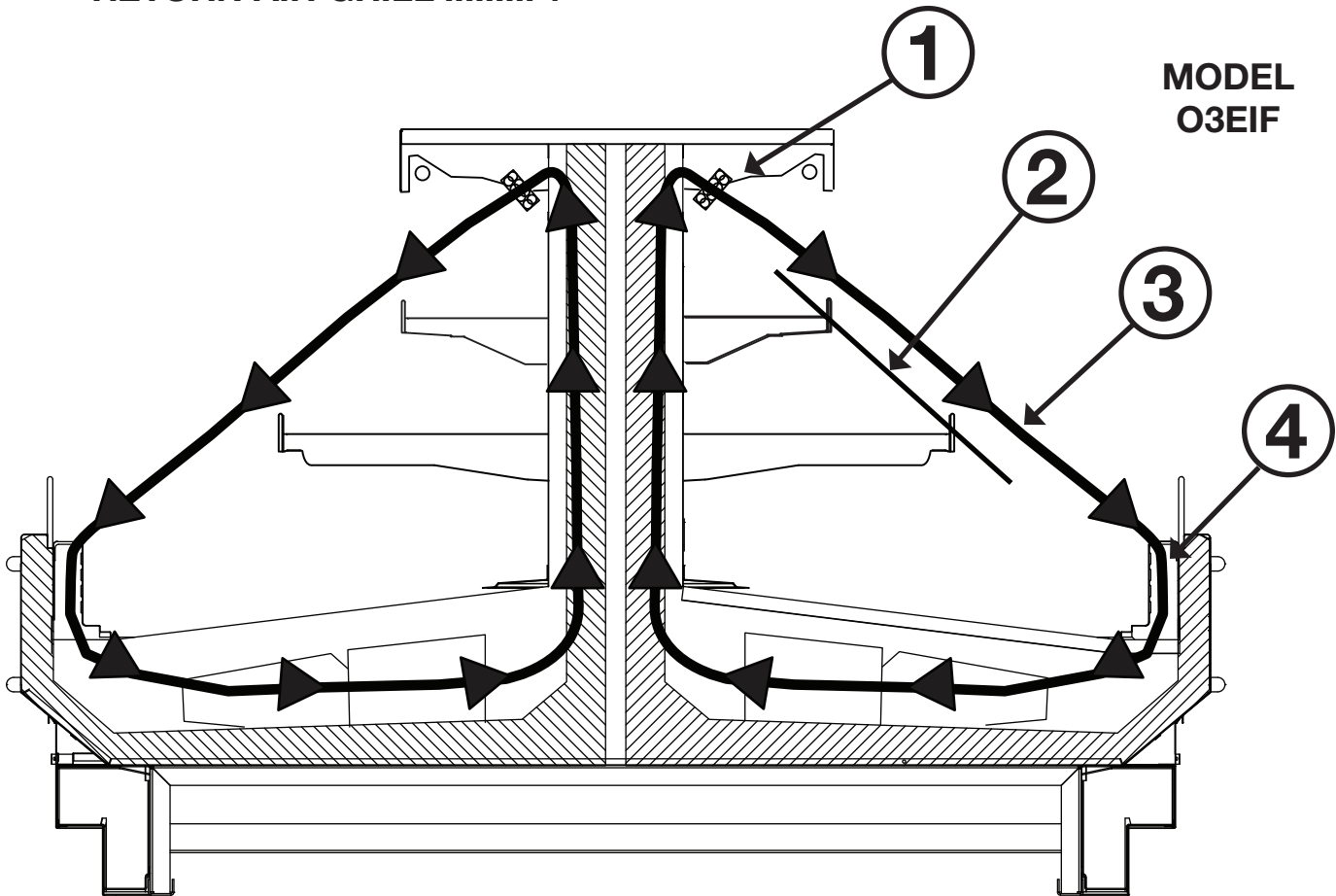

# USE & MAINTENANCE

Cases are designed to facilitate cleaning. There is a wide radius formed on the front and back of the inside bottom that helps accelerate liquid flow and eliminates difficult-to-clean sharp corners. All surfaces pitch to a deep-drawn drain trough that angles toward the front-center of the case where the 1 1/2" waste outlet is located for easy access.

The coil is covered to keep food fluids from entering, but the cover lifts up easily when cleaning is desired. The single piece fan plenum lifts up for cleaning, exposing a major portion of the inside bottom of the tank. Make certain that the fan plenum is properly closed after cleaning to avoid air leaks. Front return air grills snap out for cleaning - no fasteners are used.

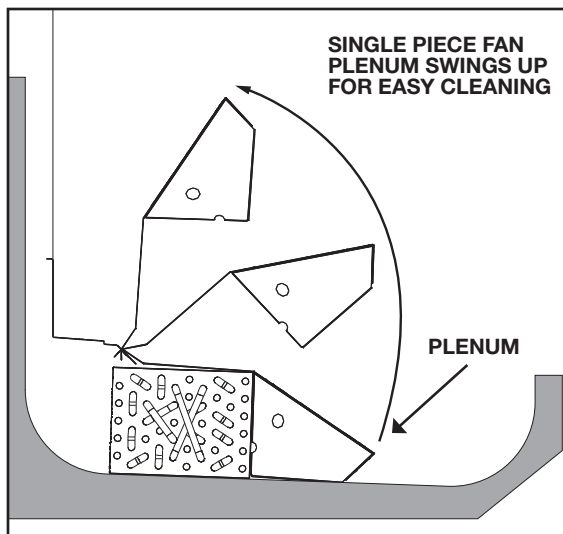

**SINGLE PIECE FAN PLENUM LIFTS UP**

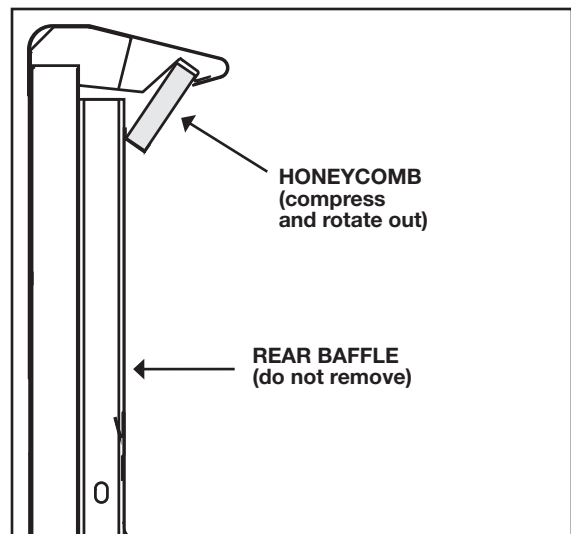

**CLEAN HONEYCOMB**

## CLEANING PROCEDURES

- A periodic cleaning schedule should be established to maintain proper sanitation, insure maximum operating efficiency, and avoid the corrosive action of food fluids on metal parts that are left on for long periods of time. We recommend cleaning once a week.
- To avoid shock hazard, be sure all electrical power is turned off before cleaning. In some installations, more than one disconnect switch may have to be turned off to completely de-energize the case.
- Check waste outlet to insure it is not clogged before starting the cleaning process and avoid introducing water faster than the case drain can carry it away.
- Avoid spraying cleaning solutions directly on fans or electrical connections.
- Provide a temporary separator between those cases which are being cleaned and those which are not.
- Allow cases to be turned off long enough to clean any frost or ice from coil and flue areas.
- Remove and clean discharge honeycomb. You may need to use spray detergent and a soft, long bristle brush.
- Use mild detergent and warm water. When necessary, water and baking soda solution will help remove case odors. Avoid abrasive scouring powders or pads.
- Remove front panels and clean underneath the case with a broom and a long handled mop. Instructions for removing the front panels can be found on page 6 of this manual.
- Use warm water and a disinfecting cleaning solution when cleaning underneath the cases.

## FANS

The evaporator fans are equipped with either 9-watt fan motors (1550 RPMs) or 12-watt fan motors (1650 RPMs). Both motors have a counter-clockwise rotation when viewed from the shaft end.

The fan blades are 8" in diameter and are pitched to varying degrees on each model as shown in the table below. It is important that the blade pitch be maintained as specified. Do not attempt a field modification by altering the blades.

Fan motors may be changed with an easy two-step process without lifting up the plenum, thereby avoiding the necessity to unload the entire product display to make a change:

1. Unplug the fan motor, easily accessible outside the plenum.
2. Remove the fasteners, then lift out the entire fan basket.

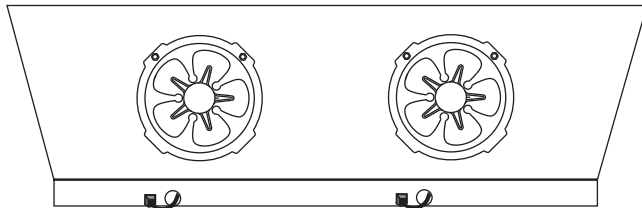
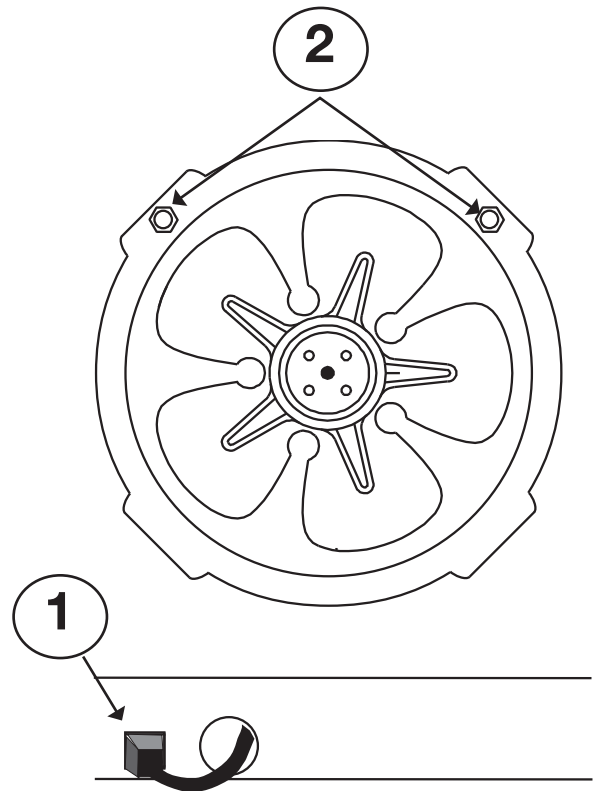

Model	Blade Size	Blade Pitch	Watts	RPMs
O3EIF				
Narrow Crown	6"	20°	16	1800

# PARTS ORDERING

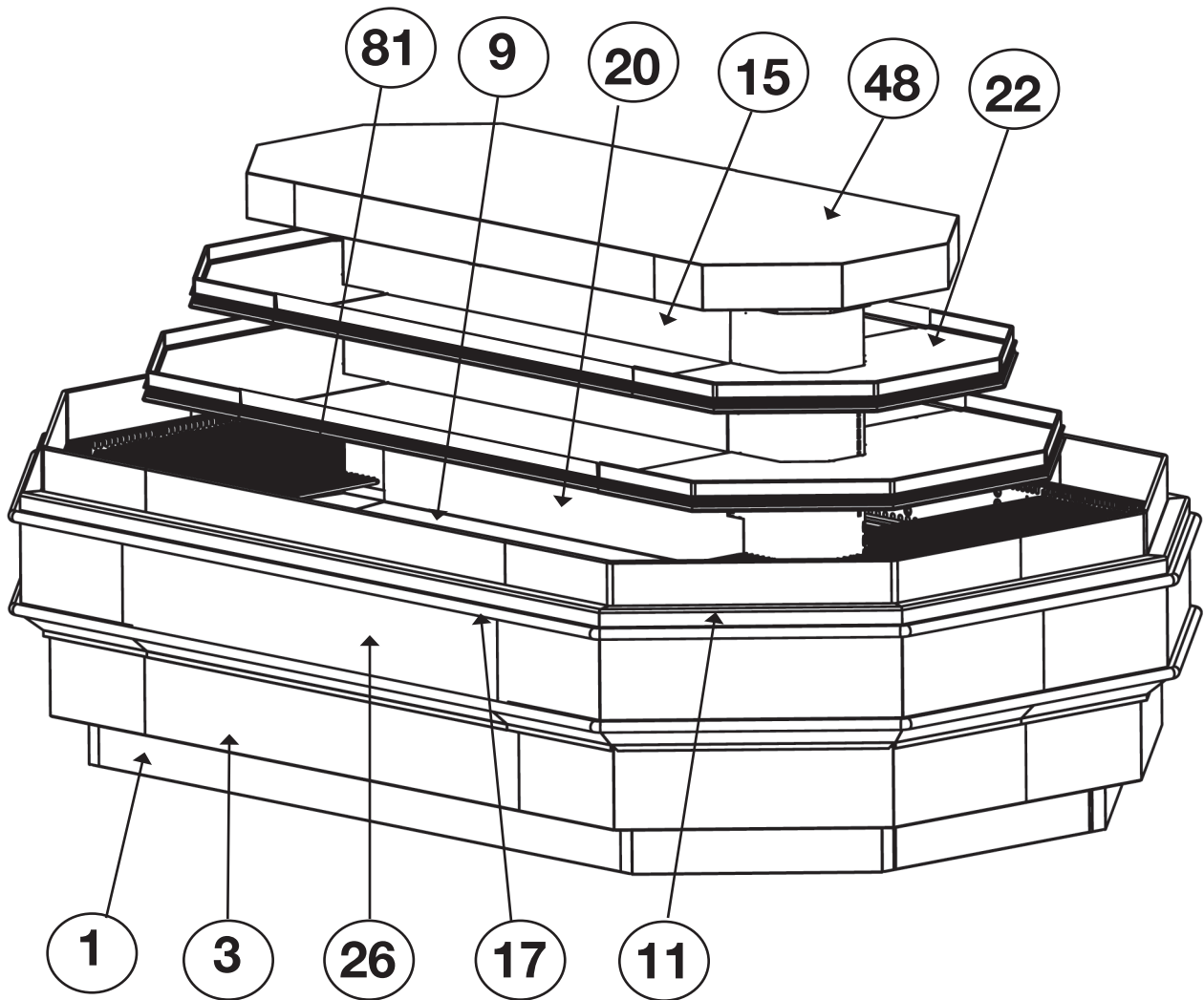

MODEL  
O3EIF

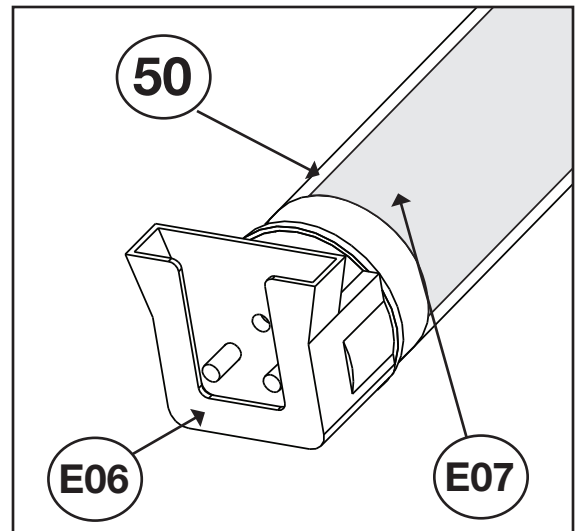
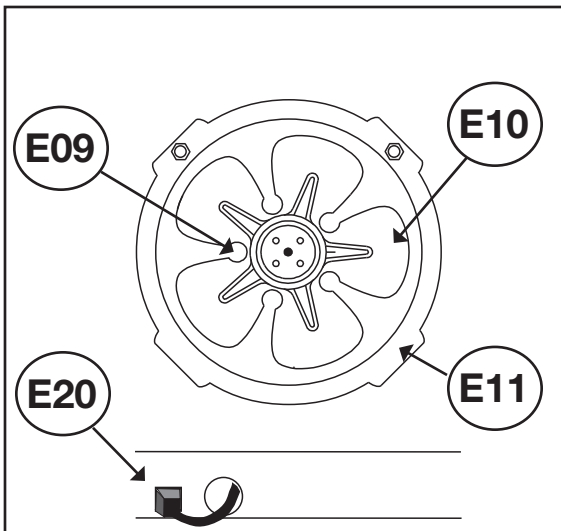

# MODEL O3EIF

<b>Location Number</b>	<b>Part Descriptions</b>
1	Kickplate, PVC Extrusion, Storm Grey
3	Lower Front Panel, Painted or Stainless
9	Deck Pan, Painted, Unpainted, or Stainless
11	Front Baffle, Aluminum, Painted, or Stainless
12	Honeycomb, Discharge, 1" x 4" x 48"
15	Rear Baffle, Painted or Stainless
17	Nose Bumper, PVC Custom Color
20	Lower Rear Baffle, Painted or Stainless
22	Shelves, Lighted or Unlighted, Painted or Stainless
26	Front Panel, Painted Custom Color
48	Rear Sill, Painted or Stainless
50	Lamp Shield
69	Coil, Not Shown
81	Bottom Wire Racks
E06	Lamp Holder
E07	Lamp
E09	Fan Motor - STATE HIGH EFFICIENCY OR STANDARD
E10	Fan Blade
E11	Fan Basket, 8"
E20	Fan Cord-Set, High Efficiency or Standard

## Order Procedure

1. Contact the Service Parts Department at 1-800-283-1109.
2. Provide the following information about the part you are ordering:
  - Model number and serial number of the case on which the part is used.
  - Length of part, if applicable.
  - Color of part if painted, or color of polymer part.
  - Whether part is for left- or right-hand application.
  - Whether shelves are with or without lights.
  - Quantity

*\*Serial plate is located on top flue panel on the right hand side of the case (See illustrations on page 3).*
3. If parts are to be returned for credit, ask the Parts Department to furnish you with a Return Material Authorization Number.



# NOTES

---

---

---

---

---

---

---

---

---

---

---

---

---

---

---

---

---

---

---

---

---

---

---

---

---

---

---

---

---

---





**WARRANTY**  
**HEREINAFTER REFERRED TO AS MANUFACTURER**

FOURTEEN MONTH WARRANTY. MANUFACTURER'S PRODUCT IS WARRANTED TO BE FREE FROM DEFECTS IN MATERIAL AND WORKMANSHIP UNDER NORMAL USE AND MAINTENANCE FOR A PERIOD OF FOURTEEN MONTHS FROM THE DATE OF ORIGINAL SHIPMENT. A NEW OR REBUILT PART TO REPLACE ANY DEFECTIVE PART WILL BE PROVIDED WITHOUT CHARGE, PROVIDED THE DEFECTIVE PART IS RETURNED TO MANUFACTURER. THE REPLACEMENT PART ASSUMES THE UNUSED PORTION OF THE WARRANTY.

This warranty does not include labor or other costs incurred for repairing, removing, installing, shipping, servicing, or handling of either defective parts or replacement parts.

The fourteen month warranty shall not apply:

1. To any unit or any part thereof which has been subject to accident, alteration, negligence, misuse or abuse, operation on improper voltage, or which has not been operated in accordance with the manufacturer's recommendation, or if the serial number of the unit has been altered, defaced, or removed.
2. When the unit, or any part thereof, is damaged by fire, flood, or other act of God.
3. Outside the continental United States.
4. To labor cost for replacement of parts, or for freight, shipping expenses, sales tax or upgrading.
5. When the operation is impaired due to improper installation.
6. When installation and startup forms are not properly complete or returned within two weeks after startup.

THIS PLAN DOES NOT COVER CONSEQUENTIAL DAMAGES. Manufacturer shall not be liable under any circumstances for any consequential damages, including loss of profit, additional labor cost, loss of refrigerant or food products, or injury to personnel or property caused by defective material or parts or for any delay in its performance hereunder due to causes beyond its control. The foregoing shall constitute the sole and exclusive remedy of any purchases and the sole and exclusive liability of Manufacturer in connection with this product.

The Warranties are Expressly in Lieu of All Other Warranties, Express of Implied and All Other Obligations or Liabilities on Our Part. The Obligation to Repair or Replace Parts or Components Judged to be Defective in Material or Workmanship States Our Entire Liability Whether Based on Tort, Contract or Warranty. We Neither Assume Nor Authorize Any Other Person to Assume for Us Any Other Liability in Connection with Our Product.

MAIL CLAIM TO:

**Hill PHOENIX**  
Display Merchandisers  
1925 Ruffin Mill Road  
Colonial Heights, VA 23834  
1-800-283-1109

**Hill PHOENIX**  
Refrigeration Systems &  
Electrical Distribution Products  
709 Sigman Road  
Conyers, GA 30013  
770-285-3200

## Warning Maintenance & Case Care

**When cleaning cases the following must be performed PRIOR to cleaning:**

**To avoid electrical shock, be sure all electric power is turned off before cleaning. In some installations, more than one switch may have to be turned off to completely de-energize the case.**

**Do not spray cleaning solution or water directly on fan motors or any electrical connections.**

**All lighting receptacles must be dried off prior to insertion and re-energizing the lighting circuit.**

**Please refer to the Use and Maintenance section of this installation manual.**



1925 Ruffin Mill Road, Colonial Heights, VA 23834  
Due to our commitment to continuous improvement all specifications are subject to change without notice.  
Hill PHOENIX is a Sustaining Member of the American Society of Quality.  
Visit our web site at [www.hillphoenix.com](http://www.hillphoenix.com)

