

GENERAL NOTES

- "---" indicates that the feature is not an option on this case model and/or the data is not yet available.
- LED lights only.

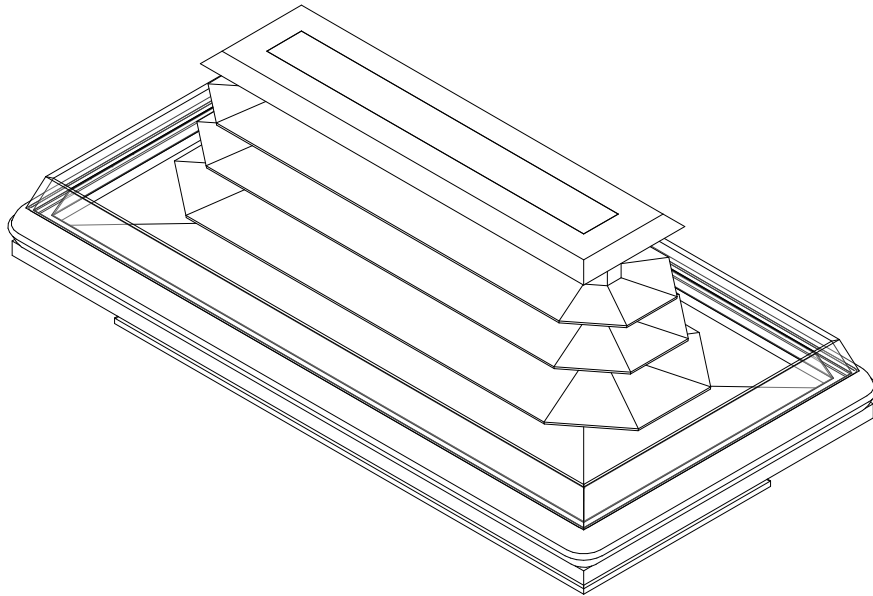

SHIPPING WEIGHT	
Case	Weight
O4ID	---



ALL MEASUREMENTS ARE TAKEN PER ASHRAE-72-2005 SPECIFICATIONS. HILLPHOENIX REFRIGERATED DISPLAY CASES FOR SALE IN THE UNITED STATES MEET OR EXCEED DEPARTMENT OF ENERGY 2017 REQUIREMENTS.

O4ID

Rev. Date	Rev. #	Rev. Title
7-25-18	2	NEW STANDARDS
12-1-17	1	DOE 2017

ELECTRICAL DATA									
Case Length	Fans Per Case	High Efficiency Fans		Anti Condensate Heaters		Defrost Heaters			
		120 Volt		120 Volts		208 Volts		240 Volts	
		Amps	Watts	Amps	Watts	Amps	Watts	Amps	Watts
8'	6	0.70	42	0.67	80	7.70	1600	8.88	2130
12'	8	0.94	56	1.06	127	11.54	2400	13.32	3200

LIGHTING DATA							
Case Length	Shelf Depth	Lights Per Row	Lights Length	Clearvoyant v4 LED Lighting (Per Light Row)			
				Standard Power (Cornice or Shelf)		High Power (Cornice Only)	
				120 Volts		120 Volts	
				Amps	Watts	Amps	Watts
8'	Top Sill	4	2 (2ft), 2 (4ft)	0.15	17.9	0.38	45.4
8'	8"	4	2 (0.5ft), 2 (3ft)	0.10	11.5	---	---
8'	10", 12", 14", 16"	4	2 (1ft), 2 (3ft)	0.11	13.2	---	---
12'	Top Sill	6	2 (2ft), 4 (4ft)	0.25	29.6	0.63	75.3
12'	8"	6	2 (0.5ft), 4 (3ft)	0.17	20.9	---	---
12'	10", 12", 14", 16"	6	2 (1ft), 4 (3ft)	0.19	22.6	---	---

GUIDELINES AND CONTROL SETTINGS						
Application	BTUH/ft		Superheat Set Point @ Bulb (°F)	Evaporator (°F)	Discharge Air (°F)	Discharge Air Velocity (FPM)
	Conventional	Parallel				
Meat	2189	1976	6 - 8	17	25	130
Deli	2023	1826	6 - 8	22	28	130

DEFROST CONTROLS							
Defrosts Per Day	Run Off Time (Min)	Electric Defrost		Timed-Off Defrost		Hot Gas Defrost	
		Fail Safe (Min)	Termination Temp (°F)	Fail-Safe (Min)	Termination Temp (°F)	Fail Safe (Min)	Termination Temp (°F)
4	6 - 8	30	47	45	45	26	45

NOTES

- "---" indicates that the feature is not an option on this case model and/or the data is not yet available.
- Listed LED lighting values represent a full row of shelves (including wrap-around ends).
- Listed BTUH/ft data represents unlighted shelves. For LED lighting, add 9 BTUH/ft per row of lighted shelving.
- Load data represents the sum of both coils.
- Listed evaporator temperature represents unlighted shelves. For lighted shelves and/or aftermarket merchandising accessories, reduce the listed evaporator temperature by 2°F. BTUH load increases by 132 BTUH/ft when aftermarket merchandising accessories are utilized.
- Listed discharge air velocity represents the average velocity at the peak of defrost.
- Temperature and defrost settings listed above are recommended start-up settings. Final operational settings may need to be adjusted for the store conditions in which the case operates.
- The recommended evaporator temperatures may need to be adjusted based on system setup, store conditions, etc. The minimum recommended evaporator temperature is 4°F below the listed evaporator temperature.



O4ID

ALL MEASUREMENTS ARE TAKEN PER ASHRAE-72-2005 SPECIFICATIONS. HILLPHOENIX REFRIGERATED DISPLAY CASES FOR SALE IN THE UNITED STATES MEET OR EXCEED DEPARTMENT OF ENERGY 2017 REQUIREMENTS.

Rev. Date	Rev. #	Rev. Title
7-25-18	2	NEW STANDARDS
12-1-17	1	DOE 2017



A DOVER COMPANY

SECOND NATURE DATA								
Case Model	No. of Coils	Application	Front Sill Type	BTUH/ft (DR)		GPM/ft (DR)	Supply Fluid Temp (F)	Discharge Air Temp (F)
				Conventional	Parallel			
O4ID	2	Meat	6" Thermopane	2189	1976	1.63	20	25
O4ID	2	Deli	6" Thermopane	2023	1826	1.51	20	28



COMPONENT

ALL MEASUREMENTS ARE TAKEN PER ASHRAE-72-2005 SPECIFICATIONS. HILLPHOENIX REFRIGERATED DISPLAY CASES FOR SALE IN THE UNITED STATES MEET OR EXCEED DEPARTMENT OF ENERGY 2017 REQUIREMENTS.

O4ID

Rev. Date	Rev. #	Rev. Title
7-25-18	2	NEW STANDARDS
12-1-17	1	DOE 2017

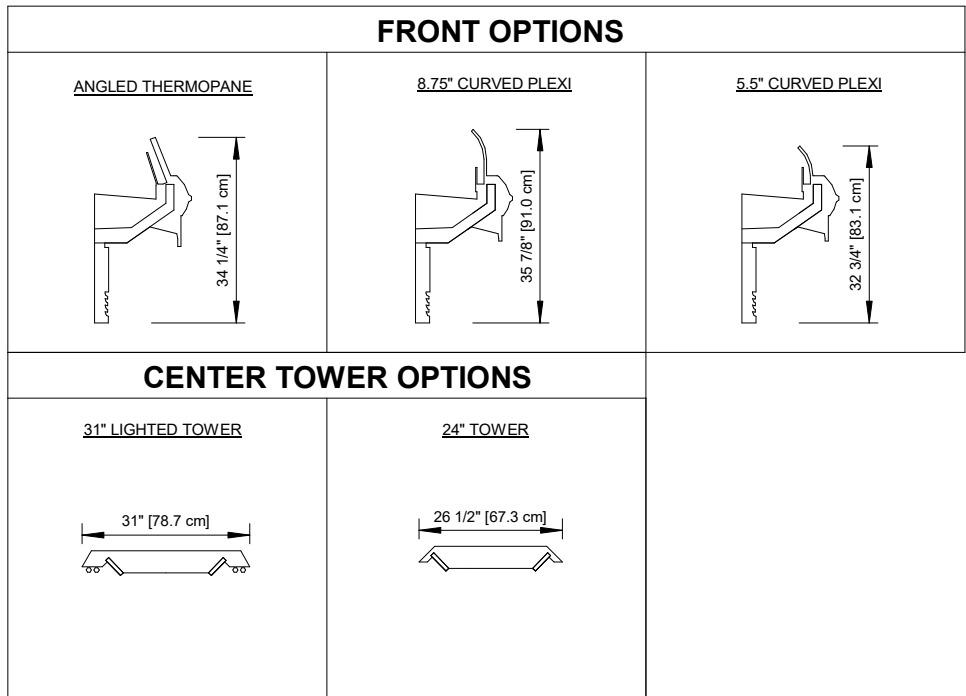

ALL MEASUREMENTS ARE TAKEN PER ASHRAE-72-2005 SPECIFICATIONS. HILLPHOENIX REFRIGERATED DISPLAY CASES FOR SALE IN THE UNITED STATES MEET OR EXCEED DEPARTMENT OF ENERGY 2017 REQUIREMENTS.

O4ID

Rev. Date	Rev. #	Rev. Title
7-25-18	2	NEW STANDARDS
12-1-17	1	DOE 2017



A DOVER COMPANY

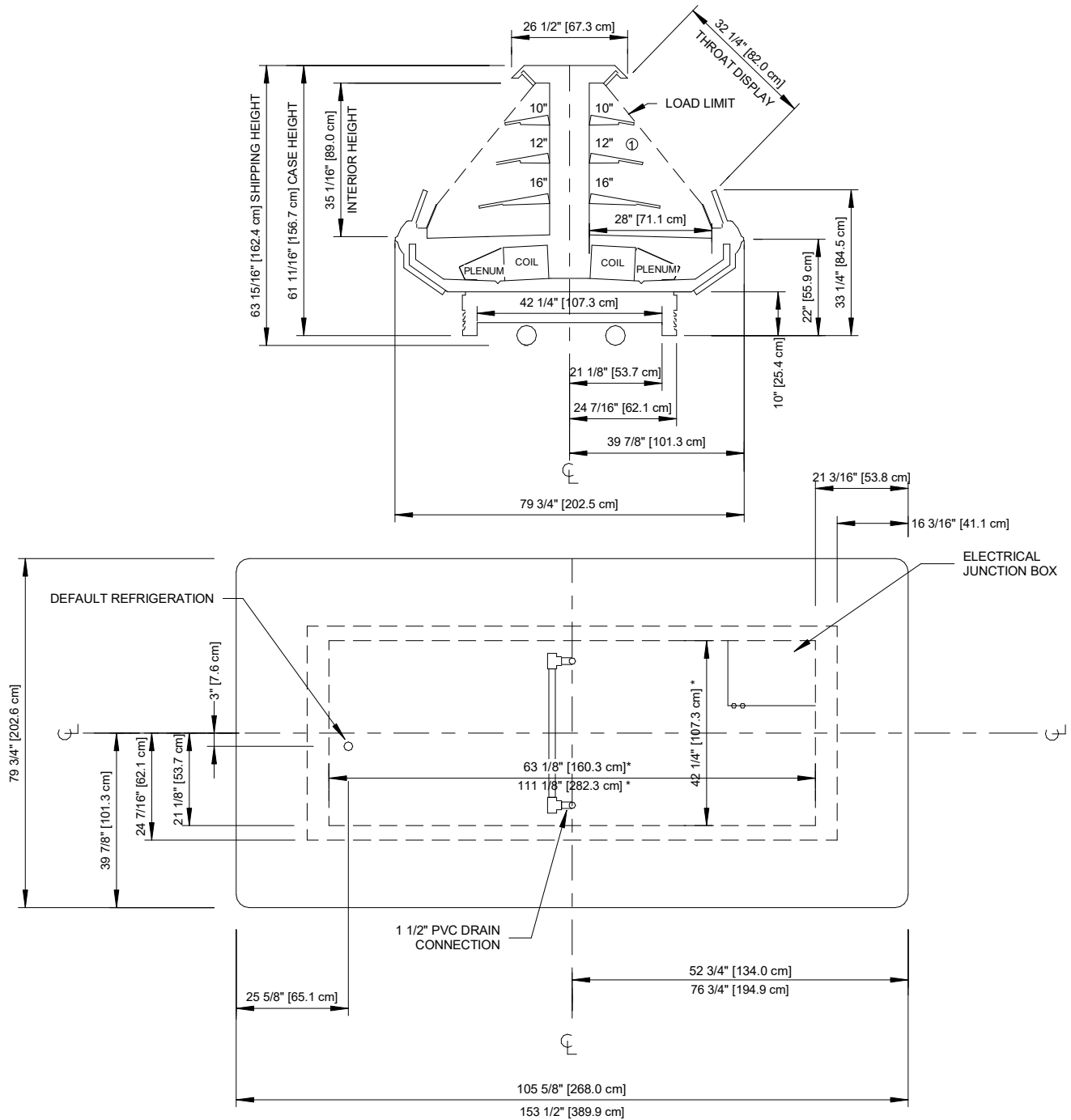

NOTES

- * : STUB-UP AREA
- Ⓢ : AVAILABLE SHELF SIZES: 10" , 12" , 14" , 16"

• Front and center sill heights vary with base frame height



O4ID

ALL MEASUREMENTS ARE TAKEN PER ASHRAE-72-2005 SPECIFICATIONS. HILLPHOENIX REFRIGERATED DISPLAY CASES FOR SALE IN THE UNITED STATES MEET OR EXCEED DEPARTMENT OF ENERGY 2017 REQUIREMENTS.

Rev. Date	Rev. #	Rev. Title
7-25-18	2	NEW STANDARDS
12-1-17	1	DOE 2017

