

Hillphoenix

A DOVER COMPANY

Fresh thinking.
Responsible solutions.

Display
Cases

Tall Rear-Load Multi-Deck

Medium temperature merchandiser for dairy, deli, produce and beverage products. Maximum merchandising capacity with up to seven shelves with a high canopy and ultra low front for easy access.

6DMLHR



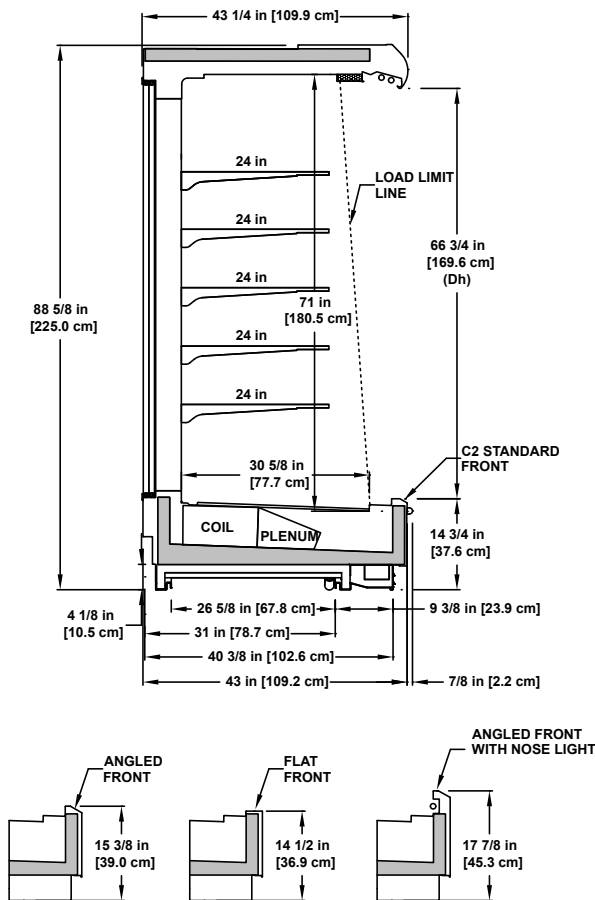

Features and Benefits

- Synerg-E Technology with NRGcoil™ ensures uniform case performance and lower average product temperatures with optimum energy efficiency.
- Bottom-mounted NRGcoil and lift-up fan plenum for ease of maintenance.
- Seamless tank liner provides positive drain runoff and enhances sanitation.
- Standard Off Cycling defrost for cost-effective operation.
- Removable castors for easy merchandiser unloading, movement and installation.
- Engineered for uniform merchandiser performance.
- Ultra-low front for easy access to larger or heavier products.
- Greatest merchandising capacity of any Hillphoenix multi-deck case.
- Up to seven shelves for high-volume merchandising.
- Roll-in, rear-load design provides easy access from walk-in cooler for restocking merchandiser, maintaining the “cold chain” for consistent product temperature.

Synerg-E® technology delivers unmatched energy efficiency without compromising the integrity of the perishable products being displayed.

Please consult Hillphoenix Engineering Reference Manual for dimensions, plan views and technical specifications. Specifications subject to change without notice. Designed for optimal performance in store environments where temperature and humidity do not exceed 75°F and 55% R.H. Certified to UL 471 and ANSI/NSF Standard 7.

Available Options

- Available lengths: 4', 6', 8', 12'.
- Multiple ultra-low front styles available.
- Available shelf sizes: 10", 12", 14", 16", 18", 20", 22", 24".
- Custom Colors, Finishes, and Textures.
- Choice of ends including full view, reduced view, solid, or square with variety of interior finishes.
- Available light options include: canopy, shelf, third row, and nose.
- Available in traditional and CO₂ direct expansion as well as secondary coolant versions.
- For non-rear loading version see 6DMLH-NRG.
- Exclusive SmartValve™ energy-saving technology available.
- Integrated energy-saving night covers available.
- Wedge versions also available.
- Exclusive Clearvoyant® LED Lighting System.



Hillphoenix
A DOWNEY COMPANY

Conyers, GA USA
844.591.5937
hillphoenix.com

©2015 Hillphoenix, Inc.

DC-M28_6DMLHRv0215