

Hillphoenix

a **DOVER** company

**BMD-R
Bakery**

Service Multi-Deck

Refrigerated bakery merchandiser.



Photo may depict options not included on standard models.

Model BMD-R Bakery Service Multi-Deck

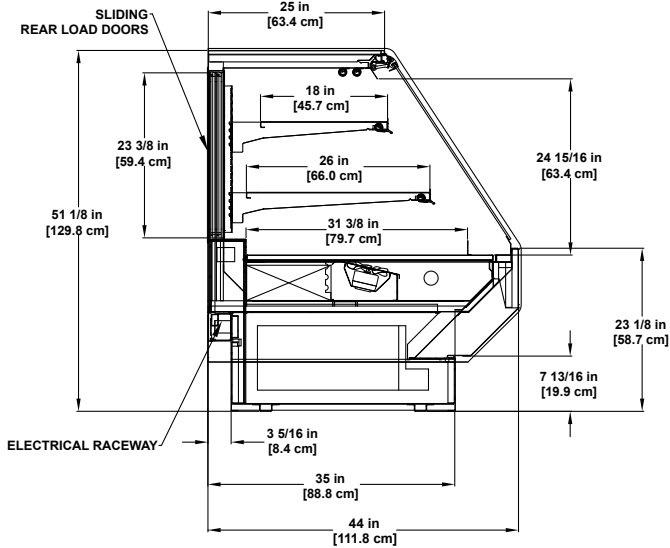

Please consult Hillphoenix Engineering Reference Manual for dimensions, plan views and technical specifications. Specifications subject to change without notice. Designed for optional performance in store environments where temperature and humidity do not exceed 75 degrees and 55% R.H. Certified to UP 471 and ANSI/NSF Standard 7.

Base Model Features

- Sled runner base construction.
- Straight back case design.
- Standard 51-1/8"H and 44"D.
- Standard 7-13/16" toekick.
- 45 degree front dieboard.
- Painted metal exterior.
- Stainless steel exterior trim.
- Stainless steel front, side and rear base trim.
- Outside back and case top painted to match exterior.
- Reflective rear load doors.
- Single-pane, flat regular-glare lift front glass.
- Black painted metal interior and trim.
- Clearvoyant® LED top light.
- Clearvoyant LED undershelf lighting.
- Rear electrical raceway.
- Solar digital thermometer.
- Remote
 - Remote shelving: 18" and 26" fixed flat, adjustable glass shelving.
- Energy efficient fans.
 - Remote DX refrigeration package.
- Dry
 - Dry shelving: 18" and 26" fixed 10° angle, adjustable wire rack shelving with price tag molding and product stop.

Available Options

- Case heights available: 48" and 54".
- Alternate toekick height include: 6-5/16"H.
- Bullet leg base with adjustable height toekick.
- Glass or solid laminated interior or mirror polished end panels.
- Exterior standard grade laminate.
- Laminate, solid surface or stone case top.
- Interior or exterior stainless steel finish.
- Interior white or other custom color finish.
- Painted base and end panel trim.
- Stainless steel outside back finish.
- Swing rear load doors.
- Flat or curved non-glare glass or curved regular glare.
- Cart bumper.
- Remote
 - Remote glycol or CO₂ refrigeration packages.



Dover Food Retail
Conyers, GA USA
844.591.5937
hillphoenix.com

©2018 Hillphoenix, Inc.



Hillphoenix company