

Hillphoenix

A DOVER COMPANY

BMD-RG

Service Single-Deck

Refrigerated gravity coil merchandiser for deli, meat and seafood applications with flat or curved lift-glass.



Photo may depict options not included on standard models.

Model BMD-RG
Service Single-Deck

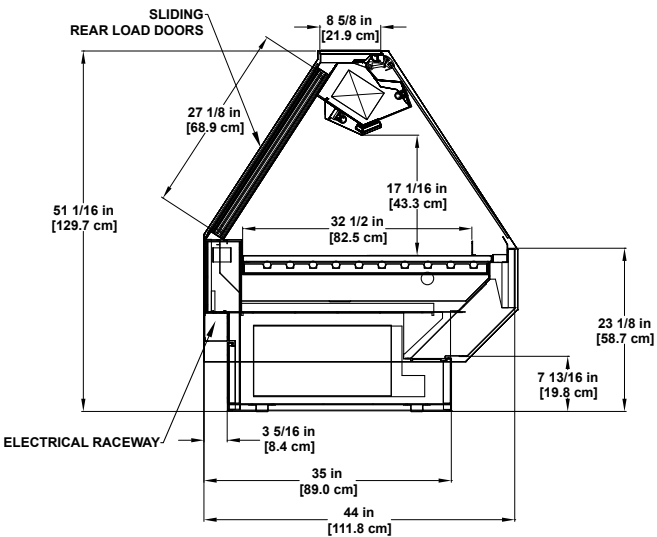

Please consult Hillphoenix Engineering Reference Manual for dimensions, plan views and technical specifications. Specifications subject to change without notice. Designed for optional performance in store environments where temperature and humidity do not exceed 75 degrees and 55% R.H. Certified to UP 471 and ANSI/NSF Standard 7.

Available Options

- Available lengths: 4', 6', 8', 10' and 12'.
- Available case heights: 54".
- Alternate toe kick height include: 6-5/16"H.
- Bullet leg base with adjustable height toe kick.
- Painted metal base trim.
- Cart bumper.
- Exterior stainless steel finish.
- Solid surface or stone case top.
- Integrated case top scale stand.
- Adjustable scale stand.
- Clear rear-load doors.
- Curved regular glare lift front glass.
- Rear fixed or flip-up work boards.
- ISO outlet/CON outlets.
- Solid interior mirror-polish stainless steel, thermal glass divider or glass ends.
- Remote glycol or CO₂ refrigeration packages.

Base Model Features

- Sled runner base construction.
- Standard 51"H and 44"D.
- 7-13/16"H toe kick height.
- 45° front die board.
- Painted metal exterior.
- Stainless steel base trim, front and sides.
- Stainless steel exterior trim.
- Stainless steel outside back and case top.
- Reflective rear load doors.
- Single-pane, regular glare, flat lift front glass.
- Stainless steel interior and trim.
- Flat bottom merchandising deck.
- Clearvoyant LED top light.
- Gravity coil with serpentine assist model.
- Rear electrical raceway.
- Solar digital thermometer.
- Remote DX refrigeration package.



Conyers, GA USA
 844.591.5937
 hillphoenix.com

©2017 Hillphoenix, Inc.

FD-BMD-RGv0917