

Self-contained Merchandisers

Refrigerated mobile merchandiser for bakery, beverage, deli, meat and produce.

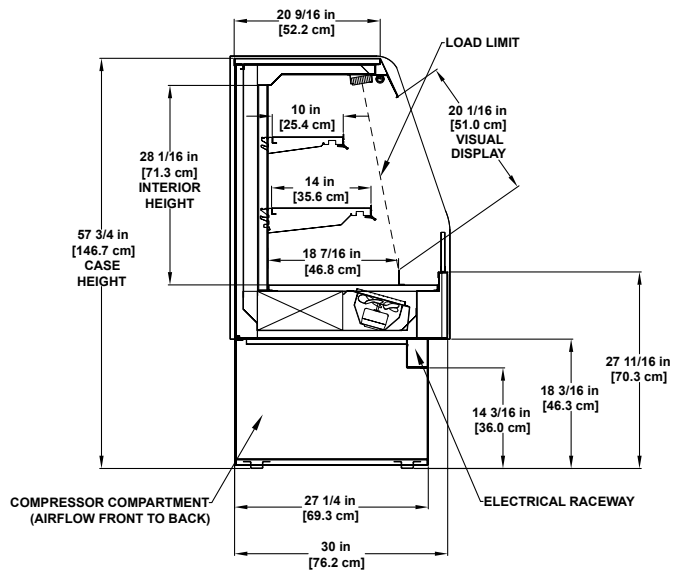
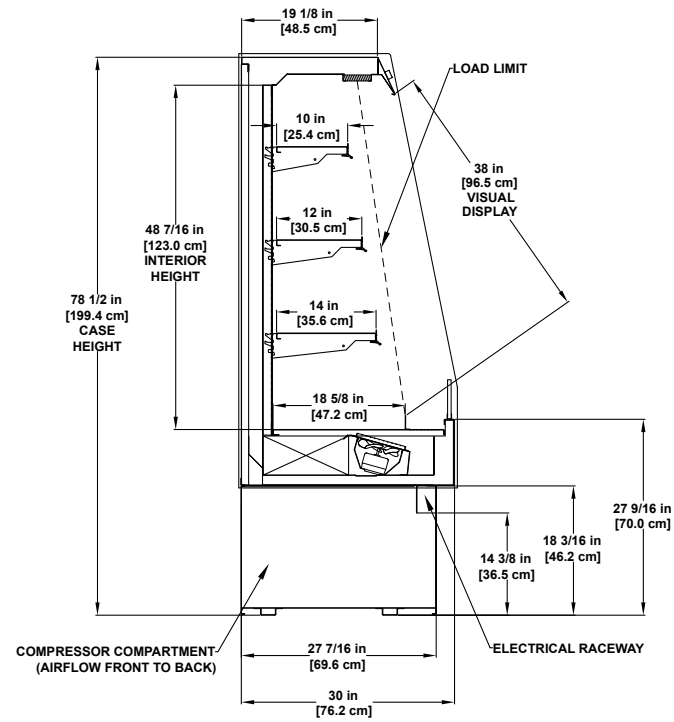

Photo may depict options not included on standard models.



57-3/4" H x 30" D

Refrigerated Multi-deck Display



78-1/2" H x 30" D

Refrigerated Multi-deck Display

Base Model Features

- Sled runner base construction.
- Closed base.
- Flat front profile.
- 18-3/16" H painted metal base, front, and sides.
- Outside back unfinished galvaneal.
- Case top painted to match the exterior.
- Painted metal exterior and trim.
- 5-1/2" H x 1/2" thick polished, straight die board plex.
- Painted metal interior and trim.
- Painted metal shelving: 10" & 14" D shelves in 57-3/4" H case
10", 12" & 14" D shelves in 78-1/2" H case.
- Painted metal, fixed, flat bottom deck.
- Left and right solid end panels.
- Energy-efficient fans.
- Solar digital thermometer.
- Front electrical raceway location.
- R-290 refrigeration package.
- R-404a & R-448a on 6' case lengths only.
- Front-to-back: straight path with rear lower exhaust.

Available Options

- See case lengths and optional depths on the chart below.
- Sled runner base construction with leveling pads, and recessed or exposed casters.
- Exterior finishes: exterior grade laminate or stainless steel.
- Exterior back panel: painted metal or stainless.
- Case top: solid surface, butcher block, laminate, poly, or stone finish.
- Interior finish: stainless steel.
- Clearvoyant® LED top light.
- Separate on/off light switch.
- Shelf finish: Stainless steel or glass.
- Shelf options: flat or angled, lighted, product stops and price tag molding.
- Night cover: roller shade or polycarbonate panel.
- Full-view, partial-view end panels or thermal divider.
- Cart bumper mounted on the front panel of the case: single or dual row.
- Cart bumper added to end panels.
- 6' UL cord and plug.
- Rear 2" chimney exhaust front-to-back airflow.
- Back to front airflow exhaust.

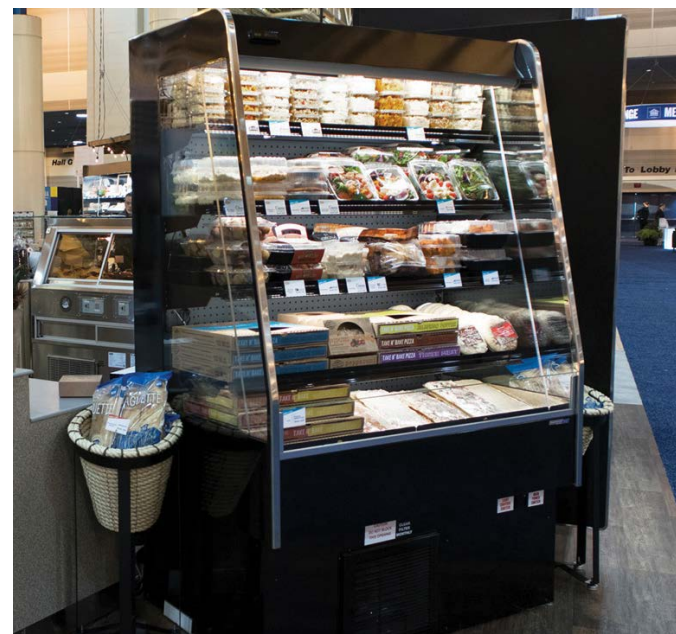

Height	Depth	Length			
		2'	3'	4'	6'
57-3/4"	30"				
	35"				
78-1/2"	30"				
	32"				

- R-290 Refrigerant
- R-404a/R-448a Refrigerant
- Not available.



Second Nature® NATURAL environmentally friendly R-290 hydrocarbon refrigerant has an ozone depletion potential (ODP) of zero (0) and a global warming potential of three (3).

R-290 models are listed for NSF Type 1.

Hillphoenix[®]

2016 Gees Mill Road
Conyers, GA 30013
770-285-3264

www.hillphoenix.com