

**Hillphoenix**

a **DOVER** company

**HVI-3-406**  
**HVI-3-408**

# Self-Service Multi-Deck

Refrigerated island merchandiser for bakery, beverage, dairy, deli and produce.



Photo may depict options not included on standard models.

Model HVI-3-406/HVI-3-408  
**Self-Service Multi-Deck**

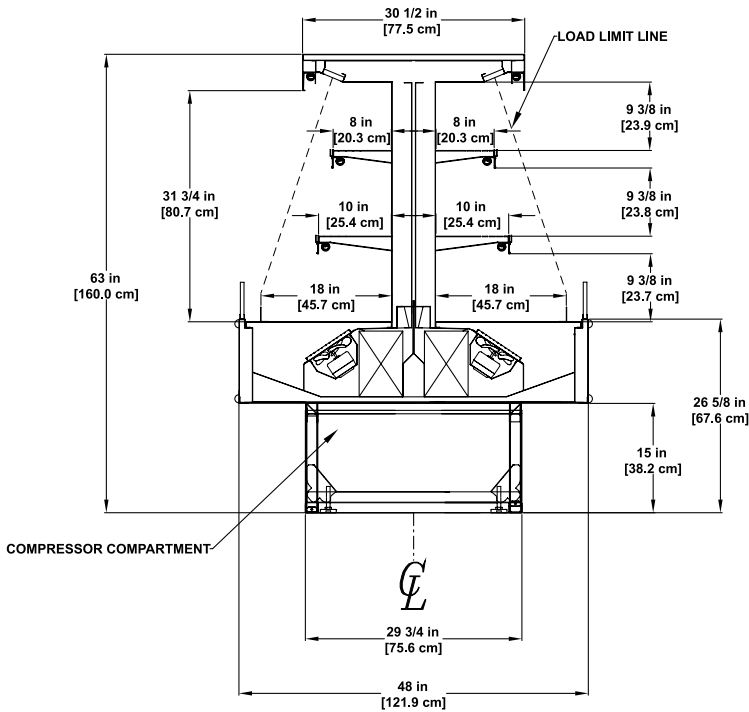

Please consult Hillphoenix Engineering Reference Manual for dimensions, plan views and technical specifications. Specifications subject to change without notice. Designed for optional performance in store environments where temperature and humidity do not exceed 75 degrees and 55% R.H. Certified to UL 471 and ANSI/NSF Standard 7.

### Base Model Features

- Sled runner base construction.
- Standard 59-7/8"H with 16-15/16"H toekick height.
- Standard top width 30.5".
  - Solid surface canopy top.
- Standard 48" width.
- Straight front dieboard.
- Two radius end caps.
- 3-1/2" tall dieboard plex.
- Painted metal exterior.
- Painted metal base trim.
- Stainless steel exterior trim.
- Black painted metal interior.
- Interior trim to match interior.
- Flat bottom merchandising deck.
- Product stop 2" tall.
- 2 Rows of upper shelves 8" and 10".
- Clearvoyant® LED cornice lighting.
- Ballast tray.
- Energy efficient fans.
- Self-contained refrigeration.

### Available Options

- Curved end caps.
- Exterior and interior stainless steel finish.
- White or other painted metal interior finish.
- Painted metal base trim.
- Solid interior painted, solid interior mirror polish stainless steel.
- Shipping casters.
- Leveling pads.
- Remote DX, glycol and CO<sub>2</sub> refrigeration packages.
- 3.5" tall product stop for remote refrigeration.
- Clearvoyant LED undershelf lights.



Dover Food Retail  
 Conyers, GA USA  
 844.591.5937  
 hillphoenix.com

©2018 Hillphoenix, Inc.

