

The Advansor CO₂ Transcritical System

Industrial Refrigeration systems have traditionally relied upon two refrigeration technologies for decades. Ammonia has been the de facto standard for very large systems. Synthetic halocarbon refrigerants — in use since the 1920s — account for the rest. Regulations put in place to control the usage of both — ammonia for its safety issues and the synthetics for their ozone depletion and global warming concerns — have made the two coolant technologies extremely problematic.

Enter CO₂ and Advansor™ by Hillphoenix .

ADVANSOR 



Industrial Refrigeration Parallel Racks

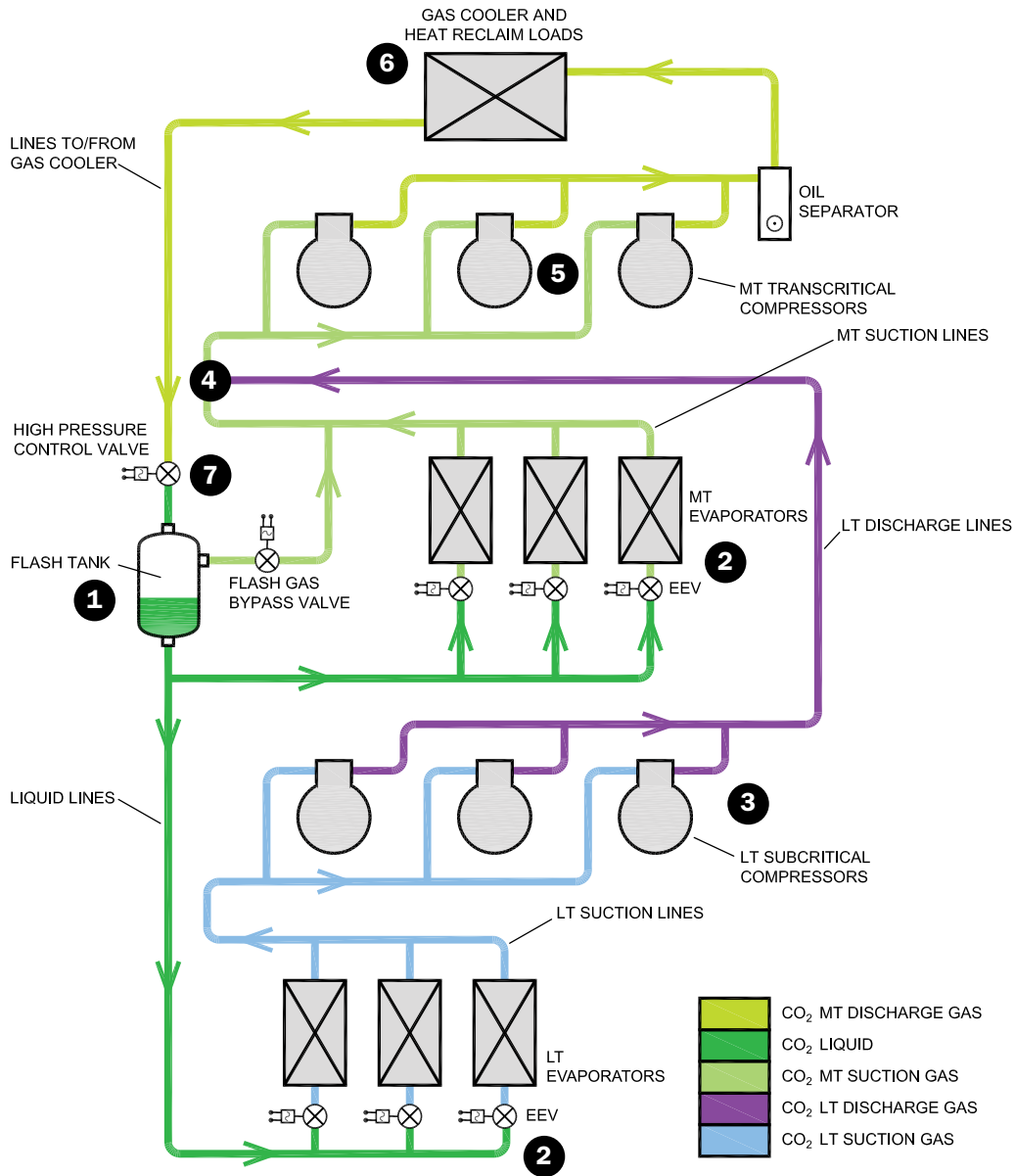

The Advansor transcritical system utilizes only one refrigerant – the abundantly available, completely sustainable and economical CO₂. CO₂ is neither flammable nor toxic, making it ideal in terms of installation and system operation. Further, all Advansor transcritical systems are carefully manufactured to achieve optimal, safe, and service-friendly operation. State-of-the-art oil control, flash gas control, and pressure regulation systems make Advansor the most reliable and energy-efficient CO₂ refrigeration system on the market.

Business owners preparing to invest in a new refrigeration system must weigh all factors that impact their Total Cost of Ownership. Environmental impact and compliance – or lack of compliance – must loom large in those considerations. Supplier credibility is just as important – and Hillphoenix has over a decade of experience and over 1500 transcritical CO₂ systems installed worldwide. Hillphoenix closes the deal with a commitment to provide guidance and training in the newest innovations and installation and maintenance best practices through the Hillphoenix Learning Center.

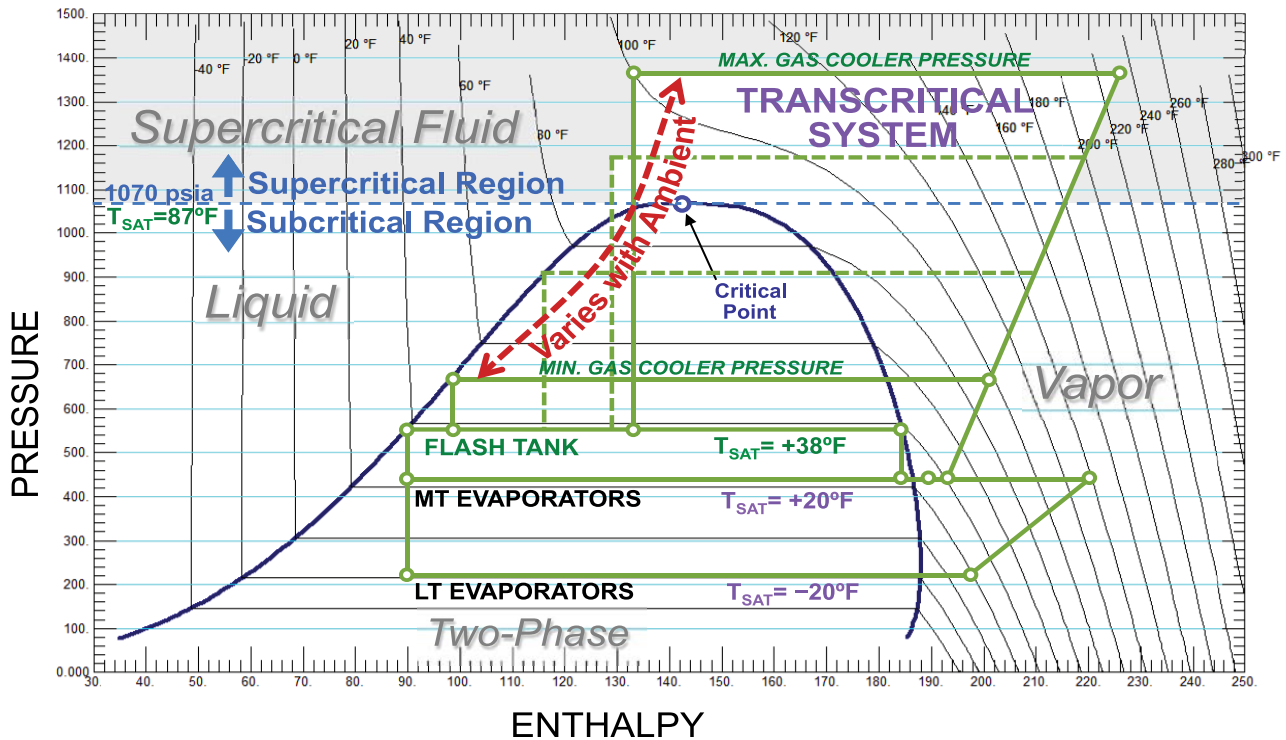

Here's how it works.

The cooling cycle begins with liquid CO₂ in the flash tank (receiver)

- (1) A network of pipes distributes the liquid to evaporators specially designed for optimum operation in CO₂ transcritical systems. Electronic expansion valves (EEVs) are in place to control the flow of CO₂ into those evaporators
- (2) Suction gas from the low-temperature evaporators returns to the rack and is compressed by the subcritical compressors to the pressure of the medium-temperature evaporators
- (3) Suction gas from the medium-temperature evaporators returns to the rack and is combined with discharge gas from the low-temperature compressors and flash gas exiting the flash tank via the flash gas bypass valve
- (4) This mixture enters the transcritical compressors and is compressed to high pressure
- (5) From there it is sent to the gas cooler where it is cooled to near ambient temperature – in cooler weather, the CO₂ in the gas cooler condenses similar to conventional systems
- (6) From the gas cooler, the CO₂ enters the high-pressure control valve where it is expanded back to subcritical pressures
- (7) The CO₂ then enters the flash tank where it is separated into liquid and gas – and the cycle begins again.



For more information, contact us at: 770.285.3264 or Hillphoenix.com.

Hillphoenix®

a **DOVER** company

Conyers, GA 30013
7770-285-3264
hillphoenix.com
©2022 Hillphoenix, Inc.



Benefits

- Easier to operate than NH₃ systems.
- More cost-efficient TCO (total cost of ownership) than NH₃ in terms of equipment, installation, and service.
- Quick and simple commissioning.
- CO₂ in cold storage areas and processing areas is safer for product and people than NH₃.
- Systems are lighter weight and command a smaller footprint.
- 100% HFC free.
- High quality heat reclaim opportunities for under-floor heating and process heating loads.
- More efficient than HFC refrigerant systems in certain climates.

Features

- Variable speed drives on lead medium- and low-temp compressors for highest energy efficiency
- Air-cooled and adiabatic gas coolers with variable speed fans.
- Electronic-controlled high pressure and flash gas bypass valves ensure optimal performance in all ambient conditions.
- Simple electronic oil management system ensures adequate lubrication for longer compressor life.
- Reliable, proven reciprocating compressors.
- Electronic expansion valves provide efficient evaporator operation.

Options

- Pre-engineered outdoor enclosure on common frame with or without optional factory-piped gas cooler.
- De-superheater on low-temperature compressor discharge for increased energy efficiency.