

## Self-Contained Mobile Island

Self-service mobile Second Nature® Natural R290 case ideal for a wide variety of medium temperature applications including: deli, dairy, cheese, produce and bakery.

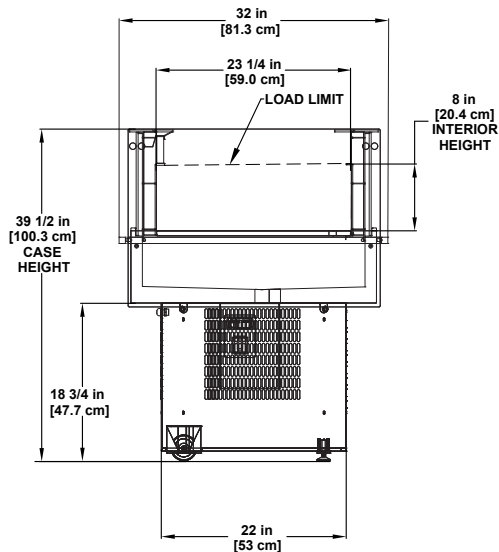

### Case Cross Section



Please consult Hillphoenix Engineering Reference Manual for dimensions, plan views and technical specifications. Specifications subject to change without notice. Designed for optimal performance in store environments where temperature and humidity do not exceed 75° F and 55% R.H. Certified to UL 471 and ANSI/NSF Standard 7.

### Features and Benefits

- Merchandising flexibility with multi-temperature capability.
- Product stack height of 8" to maximize merchandising capacity.
- Maximized product visibility and durability with Plexiglas on all four sides.
- Unique design ensures uniform case performance and lower average product temperatures with optimum energy efficiency.
- Eco-friendly natural refrigerant solution.

### Base Model Features

- 8"H stacking load line.
- 39-1/2"H.
- Footprint 32"D x 32"W.
- 23-1/4"D deck pan.
- Painted metal base - Black.
- Plexiglass integrated end panels.
- Thermopane glazed back.
- Stainless steel deck pans.
- Propane (R-290) self-contained refrigeration package.
- Wheel kit.
- Power: 115v, 60HZ, single phase with a NEMA L5-15P plug.



*This self-contained model utilizes Second Nature® NATURAL environmentally friendly R-290 hydrocarbon refrigerant that has zero (0) ozone depletion potential (ODP) and three (3) global warming potential.*



Dover Food Retail  
Conyers, GA USA  
844.591.5937  
hillphoenix.com

**Hillphoenix**