

Self-Contained Mobile Island

Self-service mobile Second Nature® Natural R290 case ideal for a wide variety of medium temperature applications including: meat, deli, dairy, cheese, produce, bakery and meal kits.

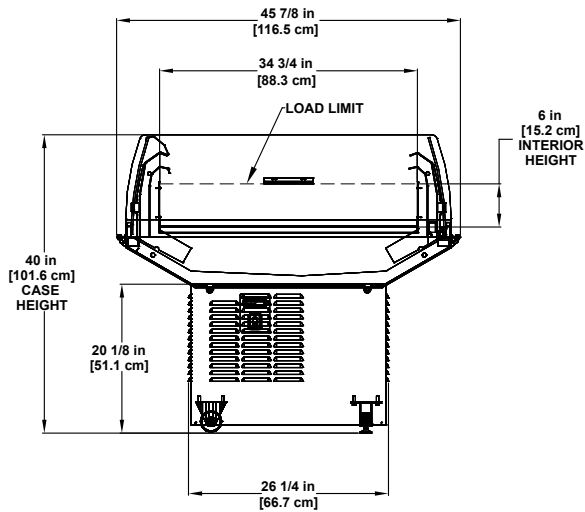

Case Cross Section



Please consult Hillphoenix Engineering Reference Manual for dimensions, plan views and technical specifications. Specifications subject to change without notice. Designed for optimal performance in store environments where temperature and humidity do not exceed 75° F and 55% R.H. Certified to UL 471 and ANSI/NSF Standard 7.

Features and Benefits

- Merchandising flexibility with multi-temperature capability.
- Product stack height of 6" to maximize merchandising capacity.
- Maximized product visibility and durability with Plexiglas on all four sides.
- Unique design ensures uniform case performance and lower average product temperatures with optimum energy efficiency.
- Eco-friendly natural refrigerant solution.

Base Model Features

- 6"H stacking load line.
- 40"H.
- Footprint 45-7/8"D x 102-13/16"W.
- 34-3/4"D deck pan.
- Painted metal base - Black.
- Plexiglass integrated end panels.
- Thermopane glazed back.
- Stainless steel deck pans.
- Propane (R-290) self-contained refrigeration package.
- Wheel kit.
- Power: Two 115v, 60Hz, single phase power cords using NEMA L5-15 plug. AMP draw requires two (2) 20 AMP circuits.



This self-contained model utilizes Second Nature® NATURAL environmentally friendly R-290 hydrocarbon refrigerant that has zero (0) ozone depletion potential (ODP) and three (3) global warming potential.



Dover Food Retail
Conyers, GA USA
844.591.5937
hillphoenix.com

Hillphoenix