

# Self-Service Multi-Deck

Deli merchandiser for pre-packaged hot food items.

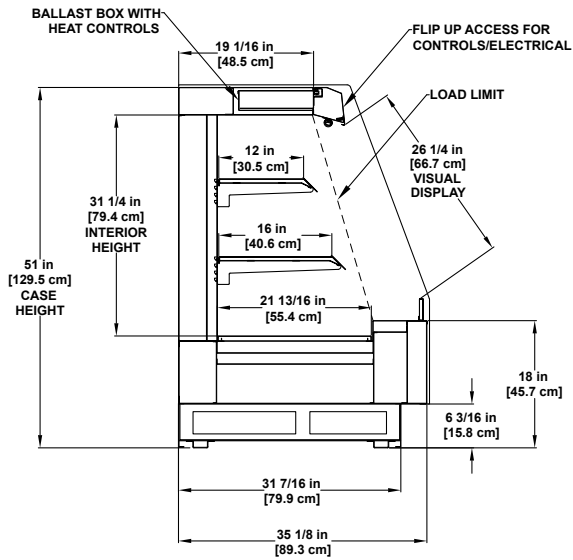



**51" PROFILE**

Please consult Hillphoenix Engineering Reference Manual for dimensions, plan views and technical specifications. Specifications subject to change without notice. Designed for optimal performance in store environments where temperature and humidity do not exceed 75° F and 55% R.H. Certified to UL 471 and ANSI/NSF Standard 4.

### Base Model Features

- Sled runner base construction.
- Straight front profile.
- Standard 51"H with 6-5/16" base height.
- Standard 35-1/8" case depth.
- Standard 19" case top depth.
- Painted metal exterior.
- Stainless steel exterior and base trim.
- Painted metal outside back.
- Stainless steel case top.
- Stainless steel interior.
- 3-1/2" glass on dieboard top.
- (1) row each 12" and 16" heated stainless steel shelving.
- Flat bottom heated merchandising deck.
- LED top light.
- LED undershelf lighting.
- Low wattage, long wave radiant heat system.
- Electronically controlled zone heating with Bluetooth connectivity.
- Controls for shelving and base heat to be mounted on the case front behind hinged top light cover.

### Available Options

- Available lengths: 4', 6' and 8'.
- Alternate height: 48" and 54"H.
- 45° front dieboard profile (requires rear controls).
- Alternate toekick height include: 7-13/16"H with no change to
- Bullet leg base with adjustable height toekick.
- Painted metal base trim.
- Cart bumper.
- Exterior stainless steel finish.
- Solid surface or stone case top.
- Rear load doors, rear controls.
- Solid interior painted, solid interior mirror polish stainless steel, thermal glass divider or glass ends.
- (1) row each 12", 14" & 16" heated stainless steel shelving on 54"H.



Dover Food Retail  
Conyers, GA USA  
770.235.3264  
hillphoenix.com

**Hillphoenix**

©2023 Hillphoenix, Inc.  
All rights reserved.