

Self-Service Multi-Deck

Self-Contained upright top-mount refrigerated air screen merchandiser for beverage, dairy and produce.

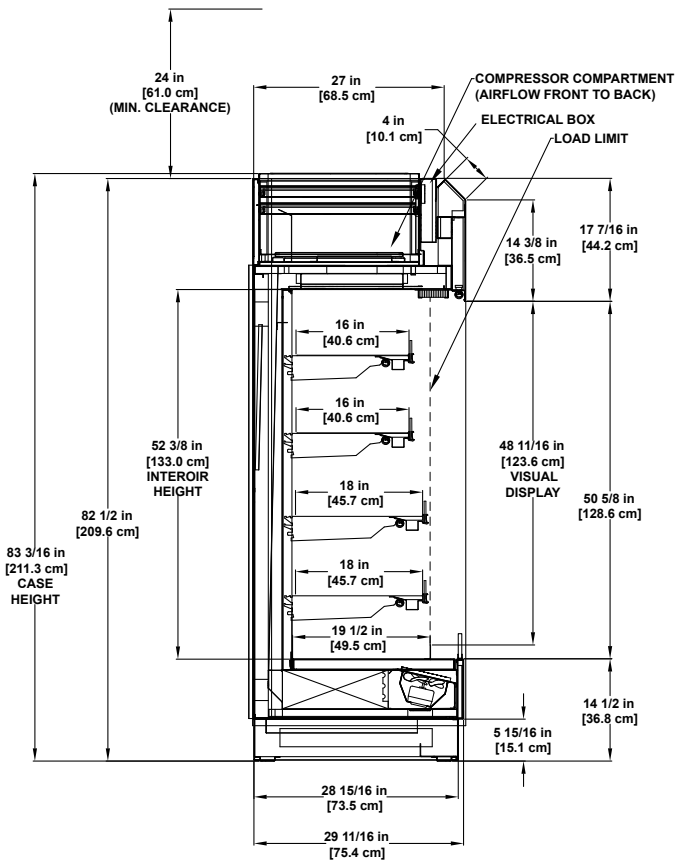

Photo may depict options not included on standard models.



Please consult Hillphoenix Engineering Reference Manual for dimensions, plan views and technical specifications. Specifications subject to change without notice. Designed for optimal performance in store environments where temperature and humidity do not exceed 80° F and 55% R.H. Certified to UL 471 and ANSI/NSF Standard 7.

Base Model Features

- Sled runner base construction.
- Case dimensions: 82-1/2"H and 30"D.
- 5-15/16"H stainless steel toekick, front and sides.
- Painted metal exterior.
- Solid cornice painted metal to match exterior.
- Outside back and rear toekick galvanized.
- Stainless steel exterior trim.
- 3-1/2"H x 1/2" thick polished, straight die board plex.
- Painted matte black metal interior and trim.
- (1) row Clearvoyant® LED top light.
- (2) rows 16" and (2) rows 18" non-lighted adjustable flat black painted metal shelving with black price tag molding.
- Painted black metal, flat bottom deck with 2" metal product stop.
- Main power switch and on/off light switch.
- Solar digital thermometer.
- Refrigeration: R-290, high-efficiency fan motors, and digital temperature control with automatic defrost.
- Top ballast electrical box located towards front of case.
- 6' Cord and plug.

Available Options

- Case length: 47".
- Exterior finishes: Exterior grade laminate or stainless steel.
- Painted metal base trim.
- Painted or stainless steel case interior.
- Clearvoyant LED under shelf lighting.
- Addition of up to (2) additional 18" shelves.
- Second row Clearvoyant LED top light.
- Single or dual illuminated cornice – verbiage/lettering optional.
- Solid or full-view end panels with mirror-polished, stainless steel interior.
- Thermal glass divider.
- Cart bumper mounted on front panel of case.
- Cart bumper added to end panels.
- Econofrost night cover with or without cassette.



This self-contained model utilizes Second Nature® NATURAL environmentally friendly R-290 hydrocarbon refrigerant that has zero (0) ozone depletion potential (ODP) and three (3) global warming potential.

Listed for NSF Type 2.



Dover Food Retail
Conyers, GA USA
844.591.5937
hillphoenix.com

©2022 Hillphoenix, Inc.

Hillphoenix