

# Self-Service Multi-Deck

Upright top-mount refrigerated air screen merchandiser for beverage, dairy, deli and produce.

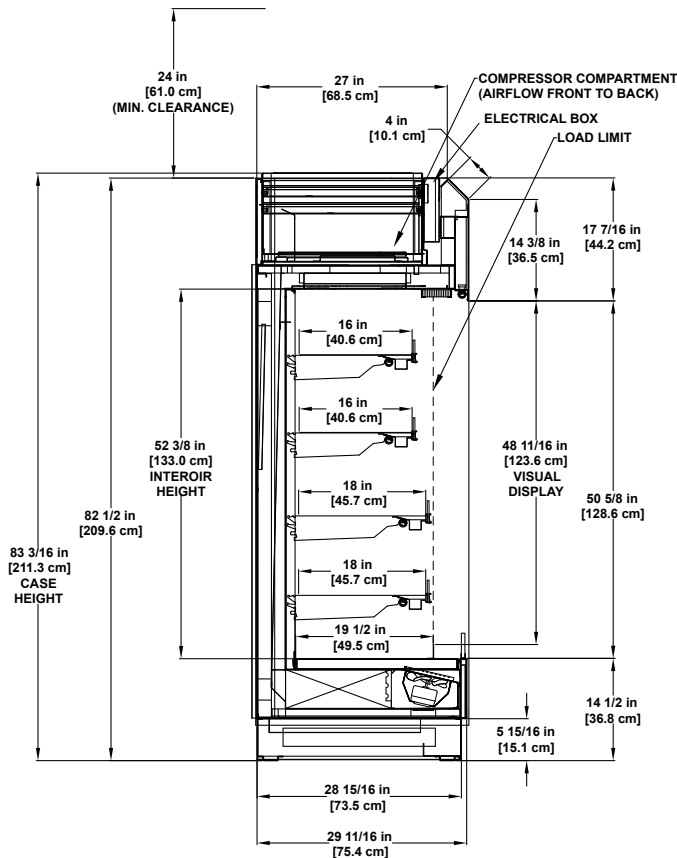



Please consult Hillphoenix Engineering Reference Manual for dimensions, plan views and technical specifications. Specifications subject to change without notice. Designed for optimal performance in store environments where temperature and humidity do not exceed 75° F and 55% R.H. Certified to UL 471 and ANSI/NSF Standard 7.

### Base Model Features

- Sled runner base construction.
- Case dimensions: 82-1/2”H and 30”D.
- 5-15/16”H stainless steel toe-kick, front and sides.
- Painted metal exterior.
- Solid cornice painted metal to match exterior.
- Outside back and rear toe-kick galvanized.
- Stainless steel exterior trim.
- 3-1/2”H x 1/2” thick polished, straight die board plex.
- Painted matte black metal interior and trim.
- (1) row Clearvoyant® LED top light.
- (4) rows each 18” non-lighted adjustable flat black painted metal shelving with black price tag molding.
- Painted black metal, flat bottom deck with 2” metal product stop.
- Main power switch and on/off light switch.
- Energy-efficient fans.
- Solar digital thermometer.
- Top ballast electrical box located towards front of case.
- 6’ Cord and plug.

### Available Options

- Case lengths: 47”, 72”, 95”, and 143”.
- 24” case depth with 4 rows 12” shelves.
- 35” case depth with 4 rows 22” shelves.
- Exterior finishes: Exterior grade laminate or stainless steel.
- Painted metal base trim.
- Painted or stainless steel case interior.
- Clearvoyant LED under shelf lighting.
- Second row Clearvoyant LED top light.
- Single or dual illuminated cornice – verbiage/lettering optional.
- Solid or full-view end panels with mirror-polished, stainless steel interior.
- Thermal glass divider.
- Cart bumper mounted on front panel of case.
- Cart bumper added to end panels.
- Econofrost night cover with or without cassette.
- Refrigeration: R-290, high-efficiency fan motors, and digital temperature control with automatic defrost on 30”D x 47”L only.



Dover Food Retail  
Conyers, GA USA  
844.591.5937  
hillphoenix.com

**Hillphoenix**

©2022 Hillphoenix, Inc.