

Service Multi-Deck

Refrigerated deli merchandiser aligns with S2SGC.

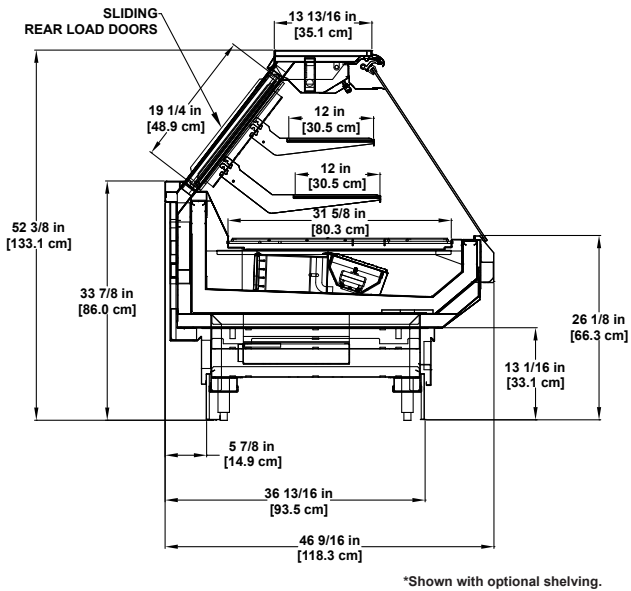

Photo may depict options not included on standard models.



Please consult Hillphoenix Engineering Reference Manual for dimensions, plan views and technical specifications. Specifications subject to change without notice. Designed for optional performance in store environments where temperature and humidity do not exceed 75°F and 55% R.H. Certified to UL 471 and ANSI/NSF Standard 7.

Base Model Features

- C-frame with bullet leg construction.
- Standard 52"H with 15"H base frame height.
- Flat front profile.
- Exterior: Painted metal, including lower front panel above base.
- Stainless steel base trim, front and sides.
- Stainless steel exterior trim.
- Painted metal outside back and rear base trim to match exterior.
- Stainless steel top sill.
- Flush stainless steel flat rear sill.
- Clear rear load doors with black frames.
- Thermopane, 5/8" insulated regular-glare flat lift front glass.
- Black painted metal interior and trim.
- Black plastic coil covers with fixed black wire rack.
- Clearvoyant® LED canopy light.
- Rear electrical box mounted behind the lower rear panel.
- Solar digital thermometer.
- Energy efficient fans.
- Remote DX refrigeration package C-frame with bullet leg construction.

Available Options

- Available lengths: 4', 6', 8' and 12'.
- Case heights available: 48" and 56".
- Alternate flexible base heights include: 11" and 19"H.
- Extruded polymer base trim.
- Painted metal base trim.
- Master or prestige bumper with nose bumper.
- Cart bumper (for flat front profile).
- Interior and exterior stainless steel finish.
- White or other painted metal interior finish.
- Solid surface or stone case top.
- Integrated case top scale stand .
- Adjustable scale stand.
- (2)rows 12" black painted metal shelving with PTM.
- Clearvoyant LED undershelf lighting.
- White plastic coil covers.
- Adjustable wire racks.
- Heavy-duty metal deck.
- Reflective rear load doors.
- Thermopane, 5/8" insulated regular-glare curved lift front glass.
- Fixed and rear flip-up work boards.
- ISO outlet/CON outlets.
- Solid interior mirror polish stainless steel, thermal glass divider or glass ends.
- Remote glycol or CO₂ refrigeration packages.



Dover Food Retail
Conyers, GA USA
844.591.5937
hillphoenix.com

Hillphoenix

©2020 Hillphoenix, Inc.