

# CNEZLA

Endcap Case Coldwall R290 Merchandiser  
Beverage/Dairy/Meat/Frozen Food/Ice Cream

**GENERAL NOTES:**

- "---" indicates that feature is not an option on this case model and/or the data is not yet available.

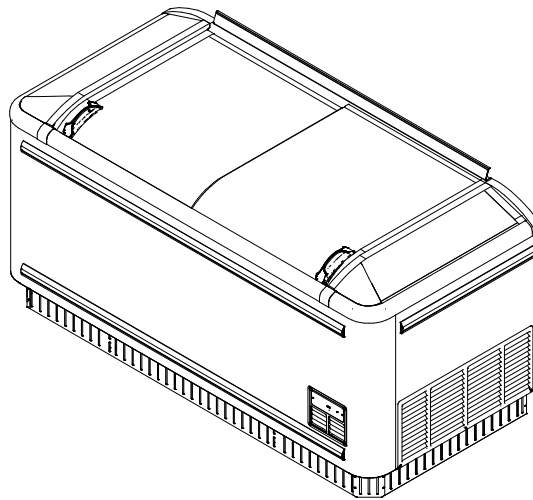

SHIPPING WEIGHT	
Case	Weight
CNEZLA	----



ENGINEERED FOR STORES WITH AMBIENT CONDITIONS NOT TO EXCEED 75° AND 55% RELATIVE HUMIDITY. DUE TO ENGINEERING IMPROVEMENTS SPECIFICATIONS MAY CHANGE WITHOUT NOTICE. ALL MEASUREMENTS ARE TAKEN PER ASHRAE-72 SPECIFICATIONS. HILLPHOENIX REFRIGERATED DISPLAY CASES FOR SALE IN THE UNITED STATES MEET OR EXCEED DEPARTMENT OF ENERGY 2017 REQUIREMENTS. NUMBERS ARE BASED ON STANDARD CASE SIZES. CONSULT ENGINEERING.

**CNEZLA**

Rev. Date	Rev. #	Rev. Title
03-17-23	1	DATA UPDATE
08-10-22	0	NEW STANDARD



SYSTEM REQUIREMENTS										
Case Length	Overall Size	Volts	Frequency (Hz)	Phase	Plug*	TLA	MCA	MOP	Product Weight (lbs)	Gross Weight (lbs)
6'	73.6" x 34.5" x 36.6"	120	50/60	1	NEMA 5-15	5.9	7.4	15	262	321

GUIDELINES AND CONTROL SETTINGS				
Application	Set Point St (°F)	Defrost Termination Temp (°F)	Defrost Interval (hr)	Fail Safe (Min)
Dairy	39	50	24	10
Meat	36	50	24	10
Frozen Food	5	50	24	10
Ice Cream	-9	50	24	10

24hr Energy		
Case Length	Application	(kWh)
6'	Dairy, Meat	1.6
6'	Frozen Food, Ice Cream	3.1

CONDENSING UNIT DATA									
Case Length	Volts	Phase	Hysteresis (Min)	Max Capacity (hp)	Running Load Amps (RLA)	Locked Rotor Amps (LRA)	Refrigerant	Refrigerant Charge (grams)	Noise Limit (dBA)
6'	120	1	2	0.75	7	Electronic Cut Off	R290	132	60

LIGHTING DATA			
Case Length	Lights per case	Amps	Watts
6'	2	0.10	13

**NOTES:**

- "---" indicates that feature is not an option on this case model and/or the data is not yet available.
- Minimum clearance for single unit installation = 3.9" (100mm).
- Minimum clearance for island arrangement: Rear = 5.5"; Side = 0".
- NEMA L5-15P locking plug available upon request.



ENGINEERED FOR STORES WITH AMBIENT CONDITIONS NOT TO EXCEED 75° AND 55% RELATIVE HUMIDITY. DUE TO ENGINEERING IMPROVEMENTS SPECIFICATIONS MAY CHANGE WITHOUT NOTICE. ALL MEASUREMENTS ARE TAKEN PER ASHRAE-72 SPECIFICATIONS. HILLPHOENIX REFRIGERATED DISPLAY CASES FOR SALE IN THE UNITED STATES MEET OR EXCEED DEPARTMENT OF ENERGY 2017 REQUIREMENTS. NUMBERS ARE BASED ON STANDARD CASE SIZES. CONSULT ENGINEERING.

**CNEZLA**

Rev. Date	Rev. #	Rev. Title
03-17-23	1	DATA UPDATE
08-10-22	0	NEW STANDARD



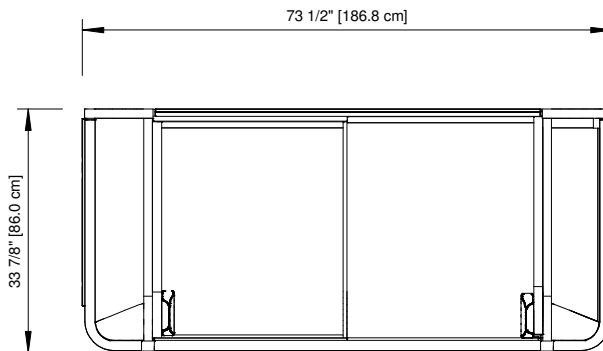
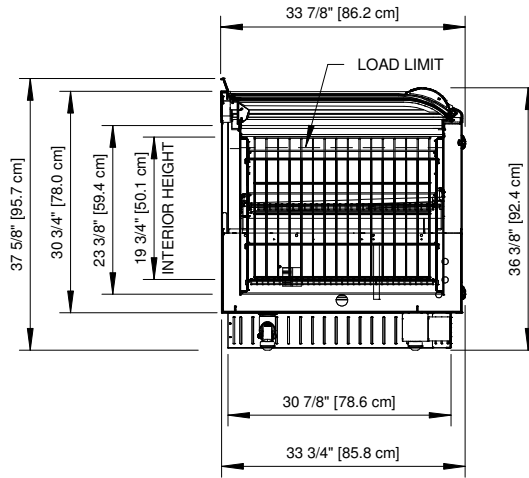

ENGINEERED FOR STORES WITH AMBIENT CONDITIONS NOT TO EXCEED 75° AND 55% RELATIVE HUMIDITY. DUE TO ENGINEERING IMPROVEMENTS SPECIFICATIONS MAY CHANGE WITHOUT NOTICE. ALL MEASUREMENTS ARE TAKEN PER ASHRAE-72 SPECIFICATIONS. HILLPHOENIX REFRIGERATED DISPLAY CASES FOR SALE IN THE UNITED STATES MEET OR EXCEED DEPARTMENT OF ENERGY 2017 REQUIREMENTS. NUMBERS ARE BASED ON STANDARD CASE SIZES. CONSULT ENGINEERING.

## CNEZLA

Rev. Date	Rev. #	Rev. Title
03-17-23	1	DATA UPDATE
08-10-22	0	NEW STANDARD