

# HVI-4-406R/408R

Self-Service Open Multi-Deck Island Merchandiser  
406 & 408 (Bakery/Beverage/Dairy/Deli/Produce)

**GENERAL NOTES:**

- "---" Indicates that the feature is not an option on this case model and/or the data is not yet available at this time.
- (SFC) Small Format Channel offering is wired for undershelf lighting.

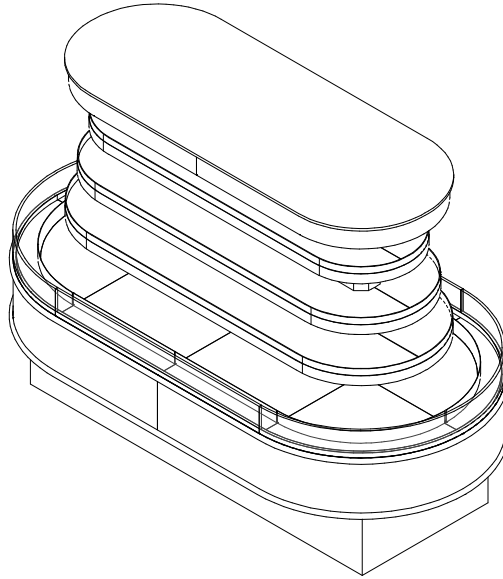

SHIPPING WEIGHT	
Case	Weight
HVI-4-406R/408R	---



ENGINEERED FOR STORES WITH AMBIENT CONDITIONS NOT TO EXCEED 75° AND 55% RELATIVE HUMIDITY. DUE TO ENGINEERING IMPROVEMENTS SPECIFICATIONS MAY CHANGE WITHOUT NOTICE. ALL MEASUREMENTS ARE TAKEN PER ASHRAE-72 SPECIFICATIONS. HILLPHOENIX REFRIGERATED DISPLAY CASES FOR SALE IN THE UNITED STATES MEET OR EXCEED DEPARTMENT OF ENERGY 2017 REQUIREMENTS. NUMBERS ARE BASED ON STANDARD CASE SIZES. CONSULT ENGINEERING.

**HVI-4-406R/408R**

Rev. Date	Rev. #	Rev. Title
03-10-22	4	DATA UPDATE
05-14-21	3	DATA UPDATE



# HVI-4-406R/408R

Self-Service Open Multi-Deck Merchandiser  
406 & 408 (Bakery/Beverage/Deli/Produce)

ELECTRICAL DATA									
Case Length	Fans Per Case	High Efficiency Fans		Anti-Condensate Fans		Drain Heaters		Optional Defrost Heaters	
		120 Volts		120 Volts		120 Volts		208 Volts	
		Amps	Watts	Amps	Watts	Amps	Watts	Amps	Watts
406	4	1.20	144	---	---	---	---	---	---
408	6	1.80	216	---	---	---	---	---	---

LIGHTING DATA							
Case Length	Light Length (Lights Per Row)	Clearvoyant 4 LED Lighting (Per Light Row)		Light Length (Lights Per Row)	Clearvoyant 4 LED Lighting (Per Light Row)		
		Standard Power (Cornice)			Standard Power (Shelf)		
		120 Volts			120 Volts		
		Amps	Watts		Amps	Watts	
406	(4) 6" + (4) 12" + (2) 24"	0.18	17.9	(6) 6" + (2) 24"	0.12	12.5	
408	(4) 6" + (4) 12" + (2) 24"	0.22	21.6	(6) 6" + (4) 24"	0.16	16.2	

GUIDELINES AND CONTROL SETTINGS (DX) {DIRECT EXPANSION HFC/CO2}						
Case Length	BTUHs		Superheat Set Point @ Bulb (°F)	Evaporator (°F)	Discharge Air (°F)	Discharge Air Velocity (FPM)
	Conventional	Parallel				
406	8707	7938	7 - 9	26	38	---
408	10100	11145	7 - 9	26	---	---

DEFROST CONTROLS {DIRECT EXPANSION HFC/CO2}							
Defrosts Per Day	Run-Off Time (Min)	Electric Defrost		Timed-Off Defrost		Hot Gas Defrost	
		Fail-Safe (Min)	Termination Temp (°F)	Fail-Safe (Min)	Termination Temp (°F)	Fail-Safe (Min)	Termination Temp (°F)
6	---	---	---	60	45	---	---

## NOTES:

- "---" Indicates that the feature is not an option on this case model and/or the data is not yet available at this time.
- High output cornice lights are not available in this case model.
- BTUH values shown include lights.
- Listed discharge air velocity represents the average velocity at the peak of defrost.
- Discharge air temperature values represent readings taken within the upper air channel immediately behind/upstream of the honeycomb.



ENGINEERED FOR STORES WITH AMBIENT CONDITIONS NOT TO EXCEED 75° AND 55% RELATIVE HUMIDITY. DUE TO ENGINEERING IMPROVEMENTS SPECIFICATIONS MAY CHANGE WITHOUT NOTICE. ALL MEASUREMENTS ARE TAKEN PER ASHRAE-72 SPECIFICATIONS. HILLPHOENIX REFRIGERATED DISPLAY CASES FOR SALE IN THE UNITED STATES MEET OR EXCEED DEPARTMENT OF ENERGY 2017 REQUIREMENTS. NUMBERS ARE BASED ON STANDARD CASE SIZES. CONSULT ENGINEERING.

## HVI-4-406R/408R

Rev. Date	Rev. #	Rev. Title
03-10-22	4	DATA UPDATE
05-14-21	3	DATA UPDATE



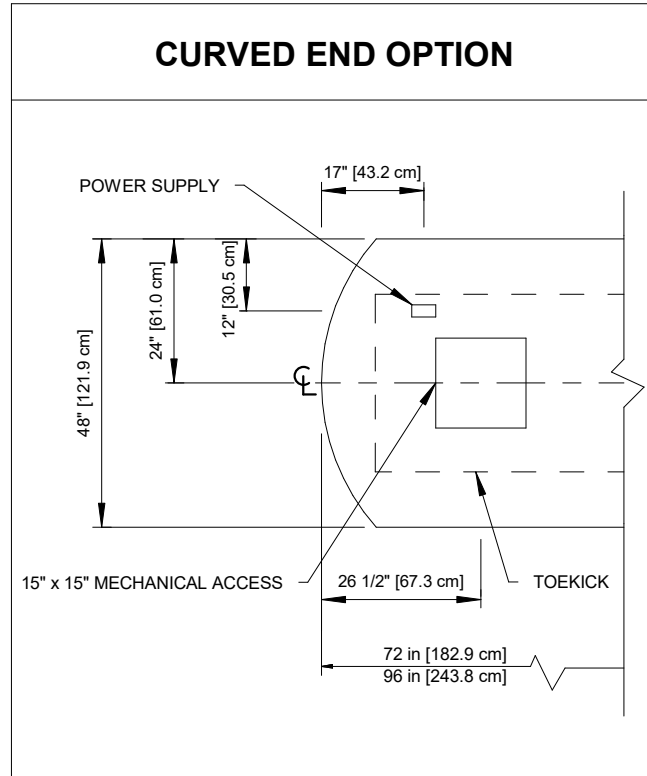

Intertek

Intertek

ENGINEERED FOR STORES WITH AMBIENT CONDITIONS NOT TO EXCEED 75° AND 55% RELATIVE HUMIDITY. DUE TO ENGINEERING IMPROVEMENTS SPECIFICATIONS MAY CHANGE WITHOUT NOTICE. ALL MEASUREMENTS ARE TAKEN PER ASHRAE-72 SPECIFICATIONS. HILLPHOENIX REFRIGERATED DISPLAY CASES FOR SALE IN THE UNITED STATES MEET OR EXCEED DEPARTMENT OF ENERGY 2017 REQUIREMENTS. NUMBERS ARE BASED ON STANDARD CASE SIZES. CONSULT ENGINEERING.

## HVI-4-406R/408R

Rev. Date	Rev. #	Rev. Title
03-10-22	4	DATA UPDATE
05-14-21	3	DATA UPDATE



a DOVER company

# HVI-4-406R/408R

Self-Service Open Multi-Deck Merchandiser  
406 & 408 (Bakery/Beverage/Deli/Produce)

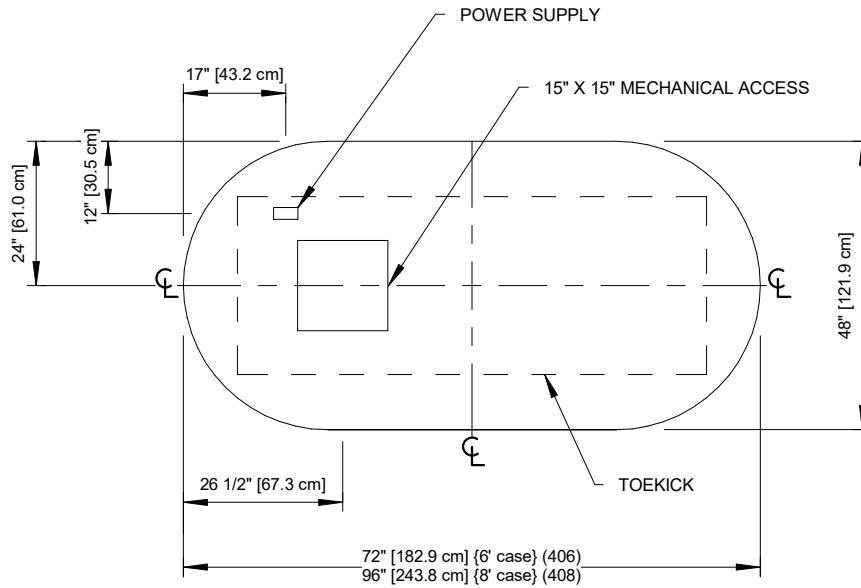
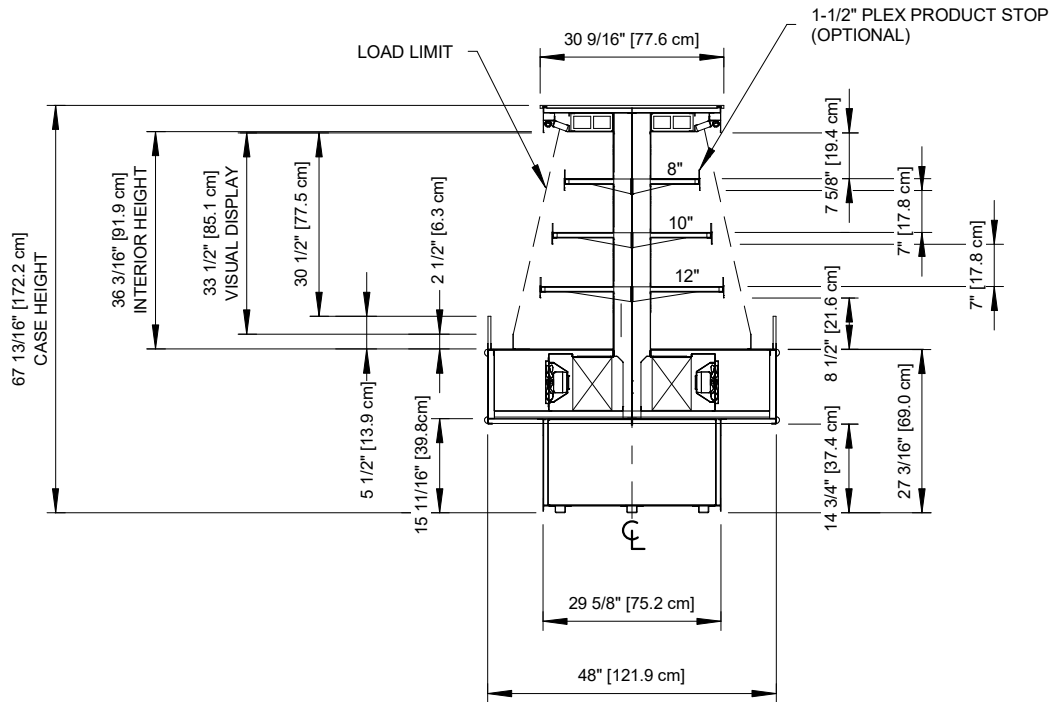

## NOTES:

- Shown with radius ends.



Intertek Intertek

ENGINEERED FOR STORES WITH AMBIENT CONDITIONS NOT TO EXCEED 75° AND 55% RELATIVE HUMIDITY. DUE TO ENGINEERING IMPROVEMENTS SPECIFICATIONS MAY CHANGE WITHOUT NOTICE. ALL MEASUREMENTS ARE TAKEN PER ASHRAE-72 SPECIFICATIONS. HILLPHOENIX REFRIGERATED DISPLAY CASES FOR SALE IN THE UNITED STATES MEET OR EXCEED DEPARTMENT OF ENERGY 2017 REQUIREMENTS. NUMBERS ARE BASED ON STANDARD CASE SIZES. CONSULT ENGINEERING.

## HVI-4-406R/408R

Rev. Date	Rev. #	Rev. Title
03-10-22	4	DATA UPDATE
05-14-21	3	DATA UPDATE



a DOVER company