

GENERAL NOTES:

- "---" Indicates that the feature is not an option on this case model and/or the data is not yet available at this time.

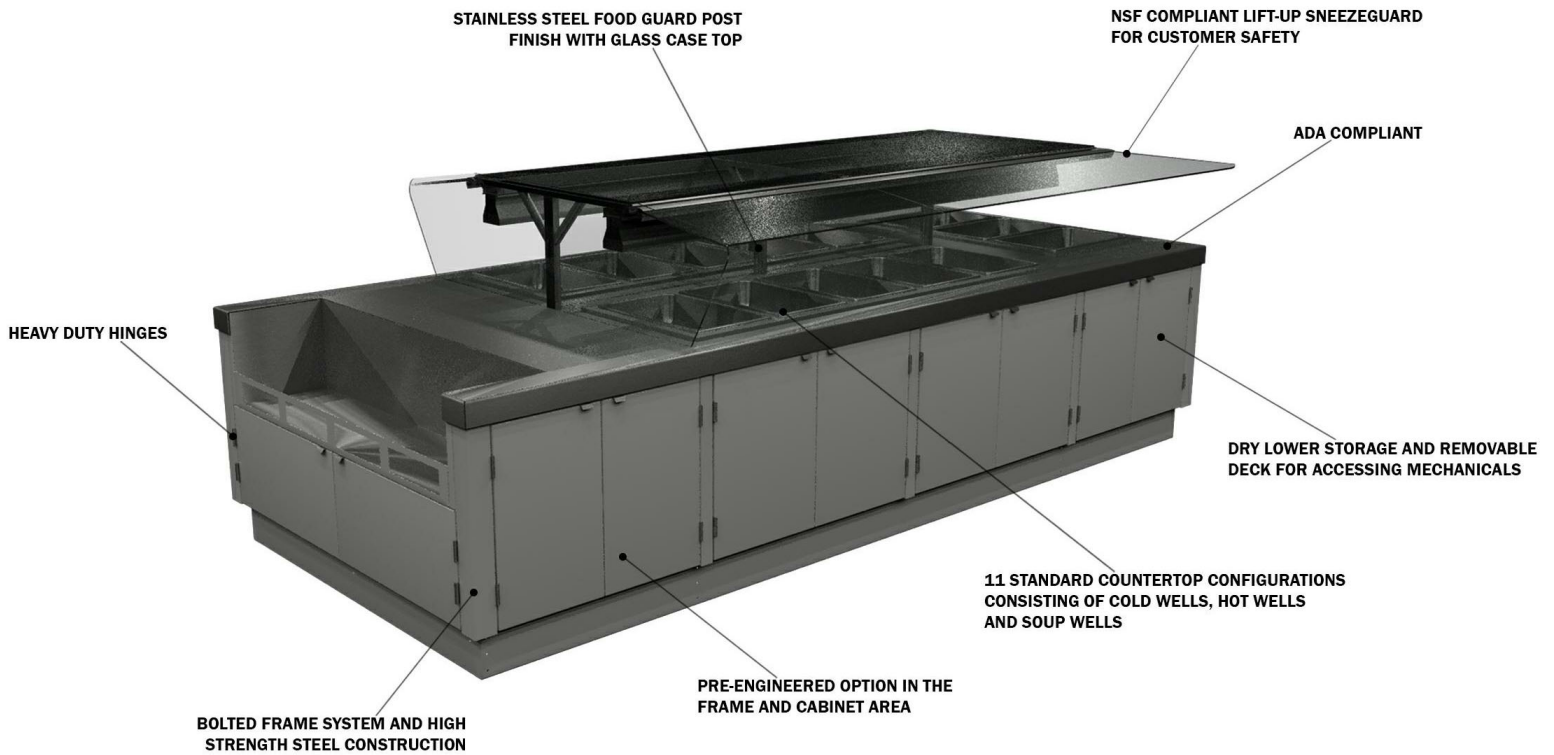

SHIPPING WEIGHT	
Case	Weight
MBI-512H-P9	---



ALL MEASUREMENTS ARE TAKEN PER ASHRAE-72-2005 SPECIFICATIONS. HILLPHOENIX REFRIGERATED DISPLAY CASES FOR SALE IN THE UNITED STATES MEET OR EXCEED DEPARTMENT OF ENERGY 2017 REQUIREMENTS.

MBI-512H-P9

Rev. Date	Rev. #	Rev. Title
04-30-20	1	NEW STANDARDS

MBI-512H-P9

Self-Service Open Salad Bar Island Merchandiser w/ Lower Storage
12' (Deli)

MBI-9			
120/208-3-60	L-1	L-2	L-3
LED LIGHTS	0.1		
TOP LIGHTS (11) 40W	3.67		
TOP HEAT (8) 400W	15.38	15.38	
CONTROL FAN	0.11	0.11	
HWBI-3MA	17.4	17.4	
HWBI-5MA CIRCUIT 1		11.6	11.6
HWBI-5MA CIRCUIT 2		17.3	17.3
HWBI-5MA CIRCUIT 1	11.6		11.6
HWBI-5MA CIRCUIT 2	17.3		17.3
TOTAL AMPS	65.56	61.79	57.8
MCA	82		
LOAD CENTER QO312L 125G			
14.25W X 17.92H X 3.75D			



COMPONENT

ALL MEASUREMENTS ARE TAKEN PER ASHRAE-72-2005 SPECIFICATIONS. HILLPHOENIX REFRIGERATED DISPLAY CASES FOR SALE IN THE UNITED STATES MEET OR EXCEED DEPARTMENT OF ENERGY 2017 REQUIREMENTS.

MBI-512H-P9

Rev. Date	Rev. #	Rev. Title
04-30-20	1	NEW STANDARDS

Hillphoenix
A DOVER COMPANY

MBI-512H-P9

Self-Service Open Salad Bar Island Merchandiser w/ Lower Storage
12' (Deli)

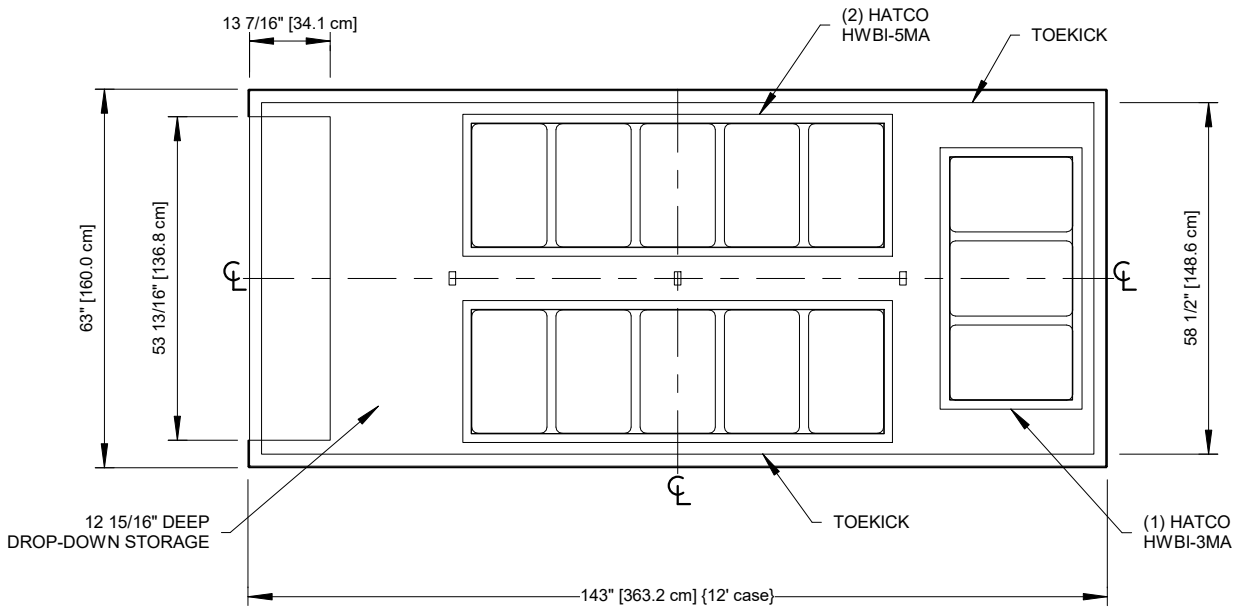
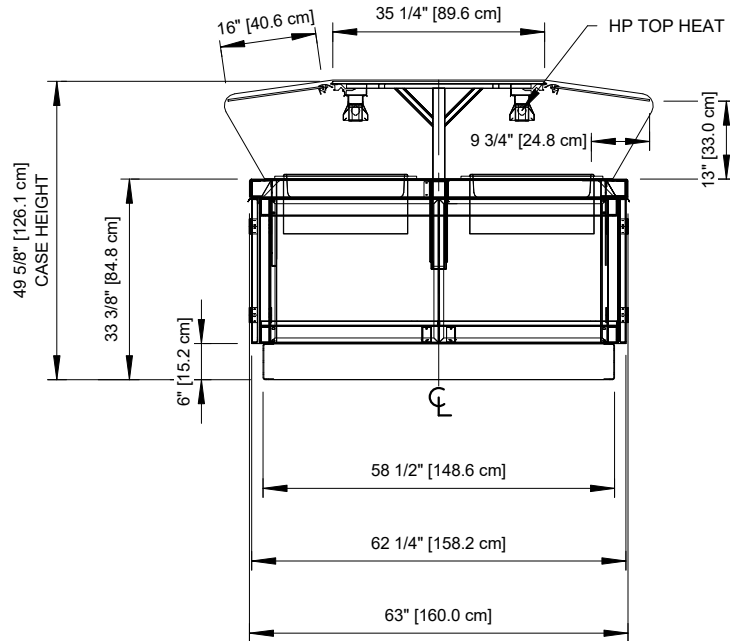

ALL MEASUREMENTS ARE TAKEN PER ASHRAE-72-2005 SPECIFICATIONS. HILLPHOENIX REFRIGERATED DISPLAY CASES FOR SALE IN THE UNITED STATES MEET OR EXCEED DEPARTMENT OF ENERGY 2017 REQUIREMENTS.

MBI-512H-P9

Rev. Date	Rev. #	Rev. Title
04-30-20	1	NEW STANDARDS

Hillphoenix
A DOVER COMPANY