

GENERAL NOTES:

- "---" Indicates that the feature is not an option on this case model and/or the data is not yet available at this time.

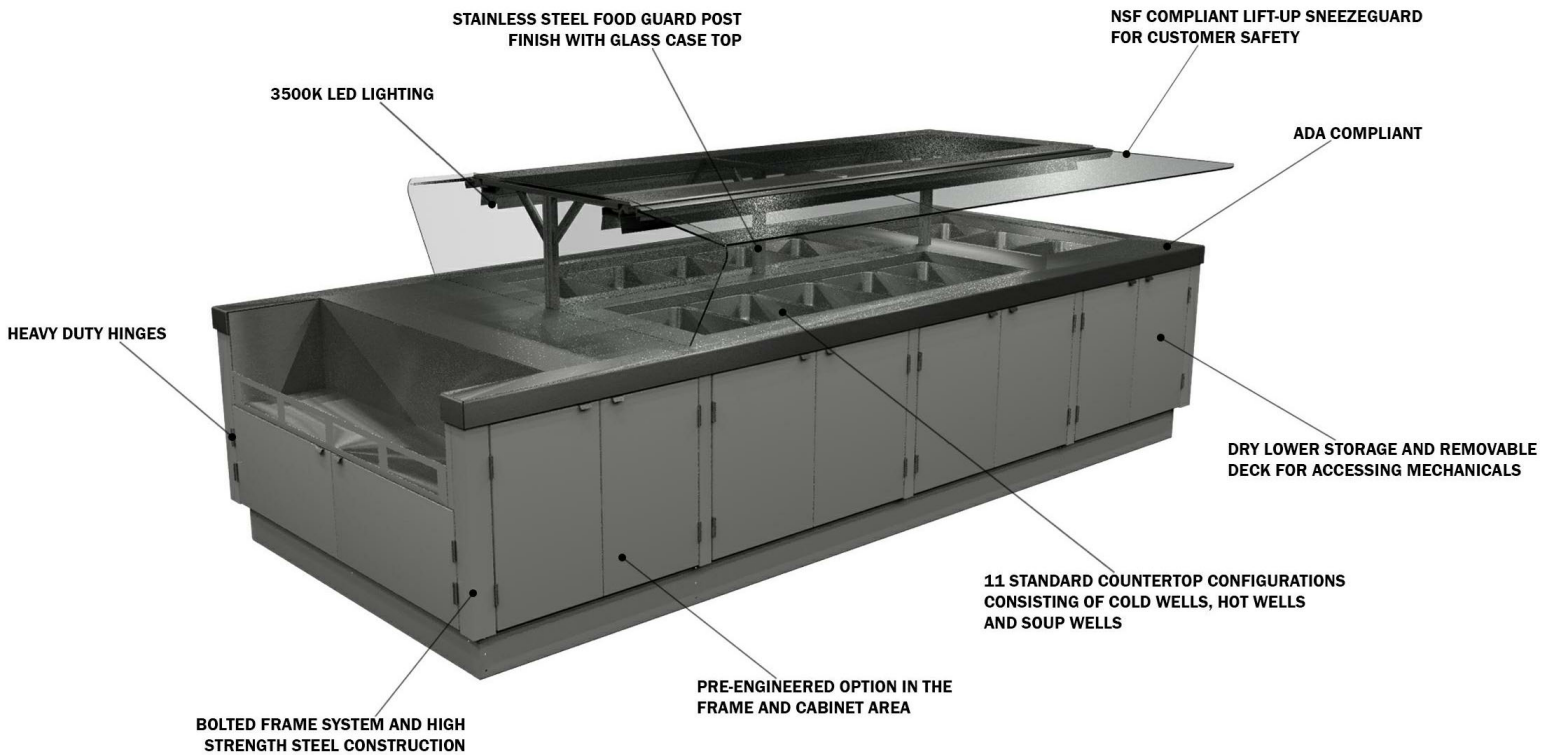

SHIPPING WEIGHT	
Case	Weight
MBI-512R-P2	---



ALL MEASUREMENTS ARE TAKEN PER ASHRAE-72-2005 SPECIFICATIONS. HILLPHOENIX REFRIGERATED DISPLAY CASES FOR SALE IN THE UNITED STATES MEET OR EXCEED DEPARTMENT OF ENERGY 2017 REQUIREMENTS.

MBI-512R-P2

Rev. Date	Rev. #	Rev. Title
04-30-20	1	NEW STANDARDS



MBI-512R-P2

MBI-2	
120-1-60	L-1
CW-EVAP FANS	1.5
LED LIGHTS	0.7
TOTAL AMPS	2.2
MCA	3
BTUs	3805
EVAP TEMP.	26°



ALL MEASUREMENTS ARE TAKEN PER ASHRAE-72-2005 SPECIFICATIONS. HILLPHOENIX REFRIGERATED DISPLAY CASES FOR SALE IN THE UNITED STATES MEET OR EXCEED DEPARTMENT OF ENERGY 2017 REQUIREMENTS.

MBI-512R-P2

Rev. Date	Rev. #	Rev. Title
04-30-20	1	NEW STANDARDS



MBI-512R-P2

Self-Service Open Salad Bar Island Merchandiser w/ Lower Storage
12' (Deli)

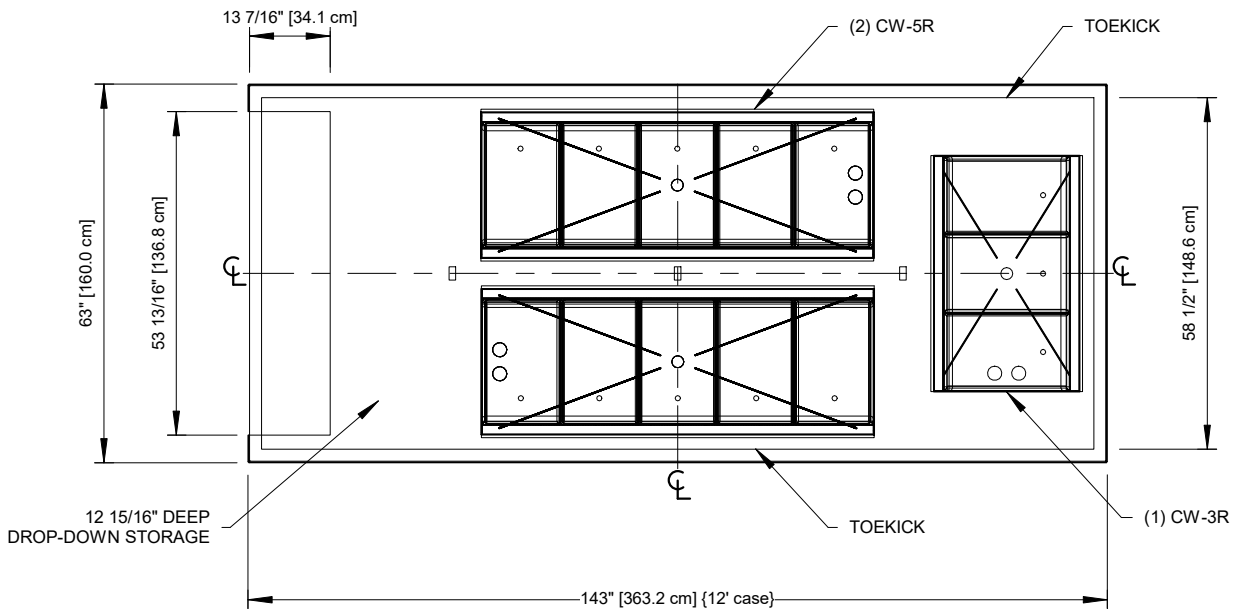
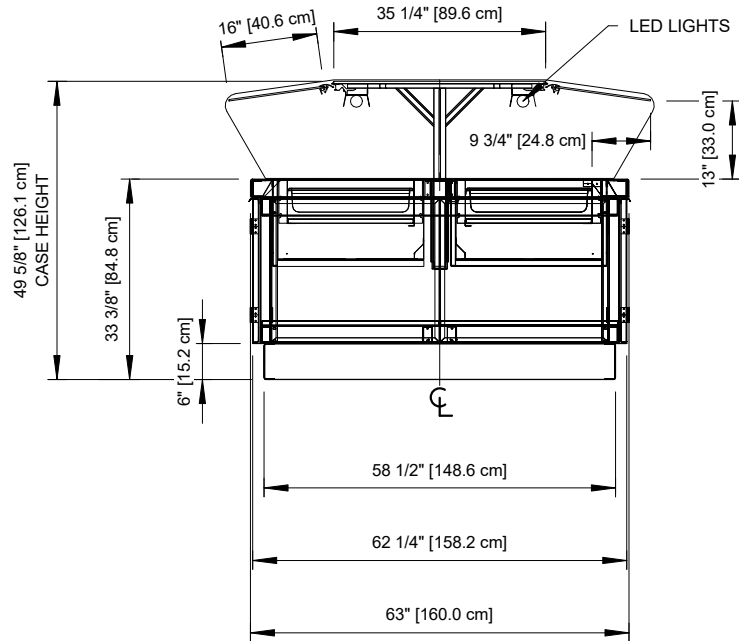

ALL MEASUREMENTS ARE TAKEN PER ASHRAE-72-2005 SPECIFICATIONS. HILLPHOENIX REFRIGERATED DISPLAY CASES FOR SALE IN THE UNITED STATES MEET OR EXCEED DEPARTMENT OF ENERGY 2017 REQUIREMENTS.

MBI-512R-P2

Rev. Date	Rev. #	Rev. Title
04-30-20	1	NEW STANDARDS

