

GENERAL NOTES:

- "---" Indicates that the feature is not an option on this case model and/or the data is not yet available at this time.

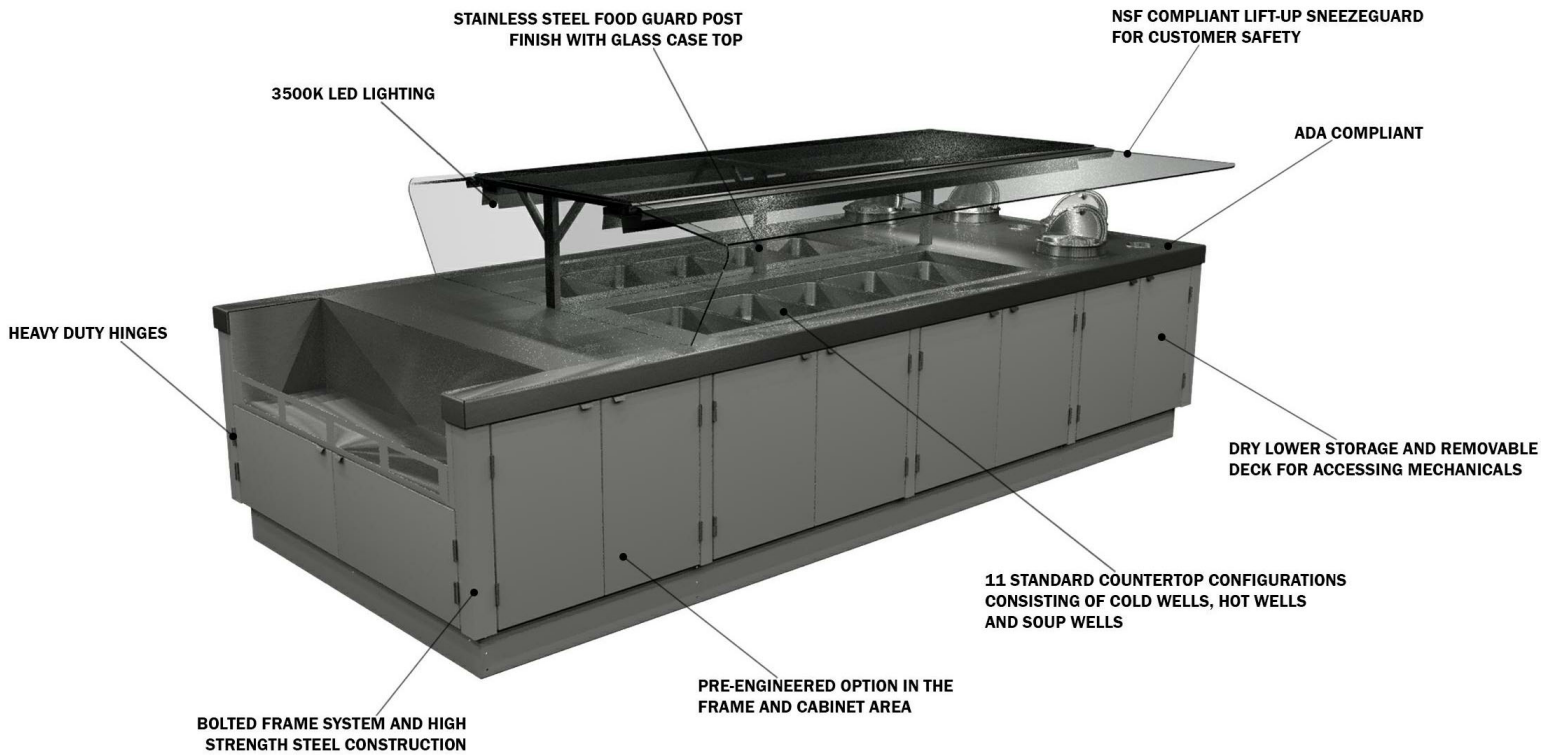

SHIPPING WEIGHT	
Case	Weight
MBI-512RH-P3	---



ALL MEASUREMENTS ARE TAKEN PER ASHRAE-72-2005 SPECIFICATIONS. HILLPHOENIX REFRIGERATED DISPLAY CASES FOR SALE IN THE UNITED STATES MEET OR EXCEED DEPARTMENT OF ENERGY 2017 REQUIREMENTS.

MBI-512RH-P3

Rev. Date	Rev. #	Rev. Title
04-30-20	1	NEW STANDARDS



MBI-512RH-P3

Self-Service Open Salad Bar Island Merchandiser w/ Lower Storage
12' (Deli)

MBI-3		
120/208-1-60	L-1	L-2
CW-EVAP FANS	1.2	
LED LIGHTS	0.7	
HWBH-11QT (4)	13.6	13.6
TOTAL AMPS	15.5	13.6
MCA	20	
BTUs	2892	
EVAP TEMP.	26°	



ALL MEASUREMENTS ARE TAKEN PER ASHRAE-72-2005 SPECIFICATIONS. HILLPHOENIX REFRIGERATED DISPLAY CASES FOR SALE IN THE UNITED STATES MEET OR EXCEED DEPARTMENT OF ENERGY 2017 REQUIREMENTS.

MBI-512RH-P3

Rev. Date	Rev. #	Rev. Title
04-30-20	1	NEW STANDARDS



MBI-512RH-P3

Self-Service Open Salad Bar Island Merchandiser w/ Lower Storage
12' (Deli)

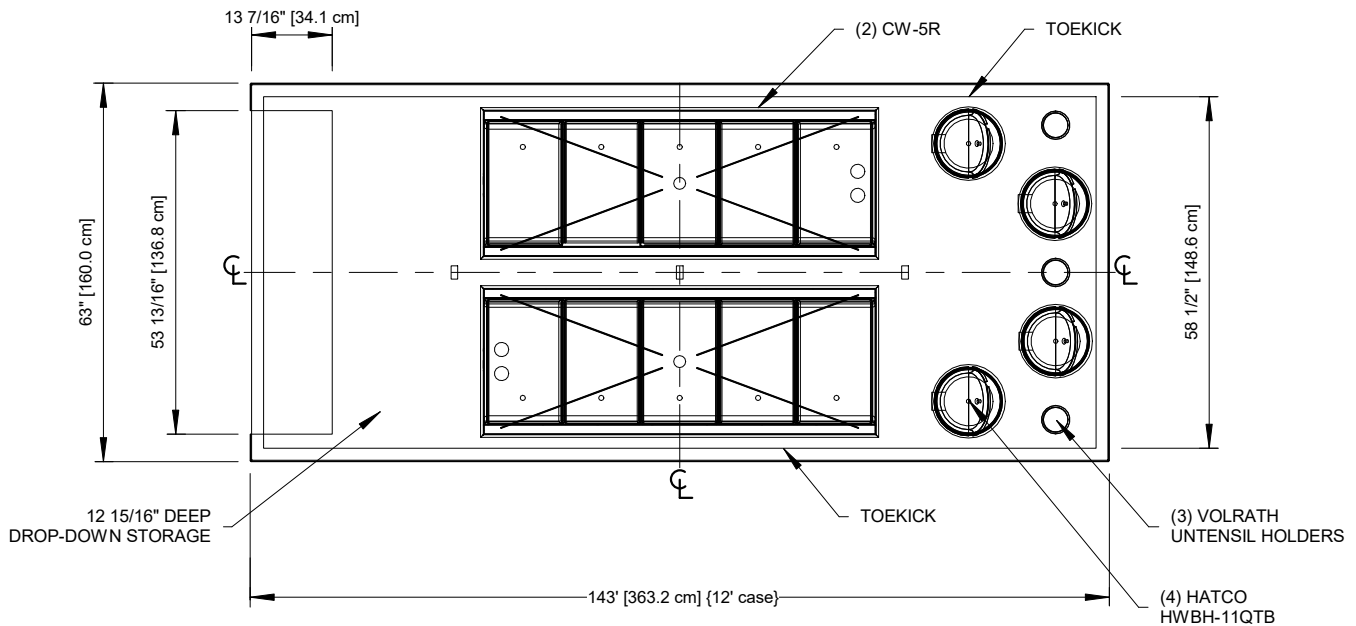
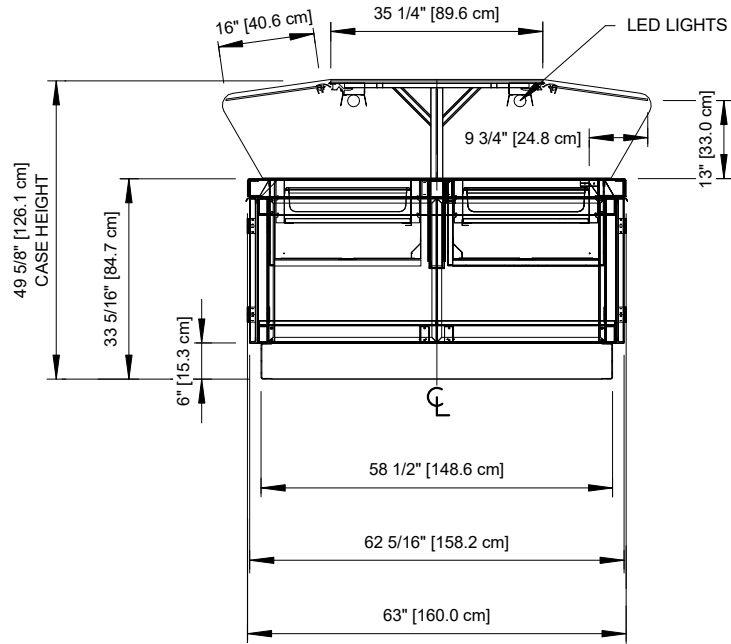

ALL MEASUREMENTS ARE TAKEN PER ASHRAE-72-2005 SPECIFICATIONS. HILLPHOENIX REFRIGERATED DISPLAY CASES FOR SALE IN THE UNITED STATES MEET OR EXCEED DEPARTMENT OF ENERGY 2017 REQUIREMENTS.

MBI-512RH-P3

Rev. Date	Rev. #	Rev. Title
04-30-20	1	NEW STANDARDS

