

# O2MZD

4', 6', 8', 12' Single Deck Merchandiser  
Frozen Food / Ice Cream

## GENERAL NOTES

- "---" indicates that the feature is not an option for this case model and/or the data is not yet available yet.

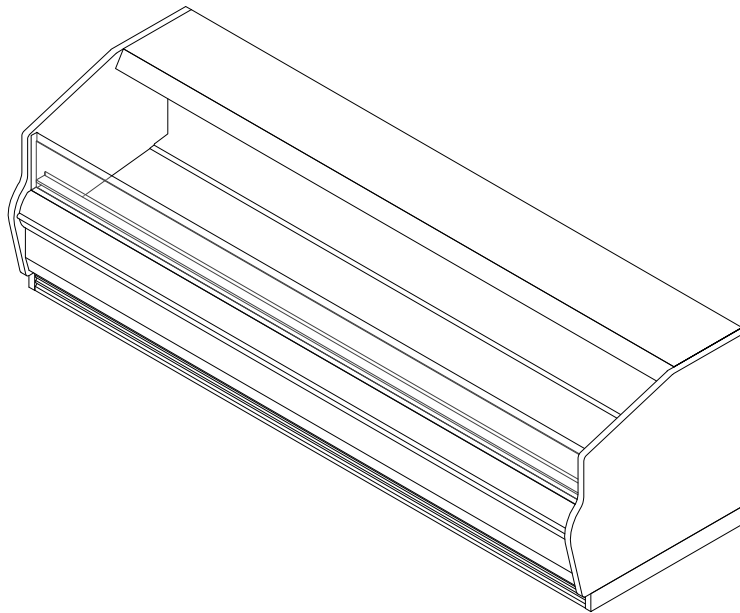

SHIPPING WEIGHT	
Case	Weight
O2MZD	---



ALL MEASUREMENTS ARE TAKEN PER ASHRAE-72-2005 SPECIFICATIONS. HILLPHOENIX REFRIGERATED DISPLAY CASES FOR SALE IN THE UNITED STATES MEET OR EXCEED DEPARTMENT OF ENERGY 2017 REQUIREMENTS.

## O2MZD

Rev. Date	Rev. #	Rev. Title
12-16-21	4	DATA UPDATE
9-12-18	3	DATA UPDATE

**Hillphoenix**  
A DOVER COMPANY

ELECTRICAL DATA									
Case Length	Fans Per Case	High Efficiency Fans		Anti-Condensate Heaters		Defrost Heaters			
		120 Volts		120 Volts		208 Volts		240 Volts	
		Amps	Watts	Amps	Watts	Amps	Watts	Amps	Watts
4'	2	0.30	22	0.30	36	7.7	1600	8.9	2130
6'	2	0.30	22	0.50	60	8.7	1800	10.0	2400
8'	2	0.30	22	0.67	82	11.5	2400	13.3	3195
12'	3	0.45	33	1.00	120	17.3	3600	20.0	4795

LIGHTING DATA					
Case Length	Lights per row	Clearvoyant v4 LED Lighting (Per Light Row)			
		Standard Power (Cornice)		High Power (Cornice)	
		120 Volts		120 Volts	
		Amps	Watts	Amps	Watts
4'	1	0.05	5.9	0.12	14.9
6'	2	0.08	9.4	0.20	23.8
8'	2	0.10	11.8	0.25	29.9
12'	3	0.15	17.6	0.37	44.8

GUIDELINES AND CONTROL SETTINGS						
Application	BTUH/ft		Superheat Set Point @ Bulb (°F)	Evaporator (°F)	Discharge Air (°F)	Discharge Air Velocity (FPM)
	Conventional	Parallel				
Frozen Food	587	562	3 - 5	-17	-5	155
Ice Cream	600	582	3 - 5	-27	-14	155

DEFROST CONTROLS					
Defrosts Per Day	Run-Off Time (Min)	Electrical Defrost		Hot Gas Defrost	
		Fail-Safe (Min)	Termination Temp (°F)	Fail-Safe (Min)	Termination Temp (°F)
2	13 - 15	60	55	30	70
2	13 - 15	60	55	30	70

**NOTES:**

- "-" indicates that feature is not an option on this case model.
- Listed BTUH/ft indicate unlighted shelves.
- Standard fans increase refrigeration load by 96 BTUH/fan.
- Average discharge air velocity at peak of defrost.



ALL MEASUREMENTS ARE TAKEN PER ASHRAE-72-2005 SPECIFICATIONS. HILLPHOENIX REFRIGERATED DISPLAY CASES FOR SALE IN THE UNITED STATES MEET OR EXCEED DEPARTMENT OF ENERGY 2017 REQUIREMENTS.

**O2MZD**

Rev. Date	Rev. #	Rev. Title
12-16-21	4	DATA UPDATE
9-12-18	3	DATA UPDATE



A DOVER COMPANY

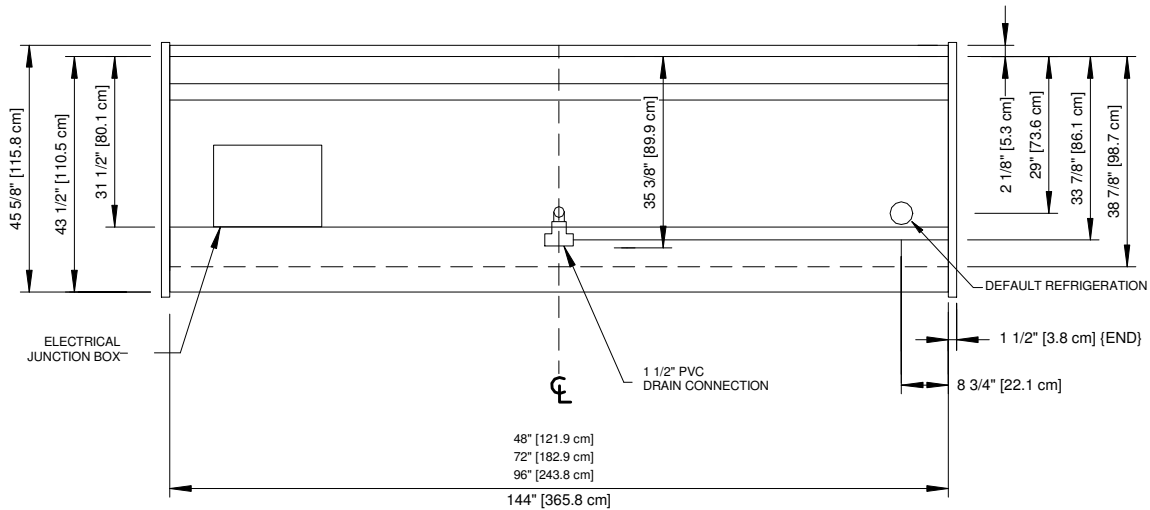
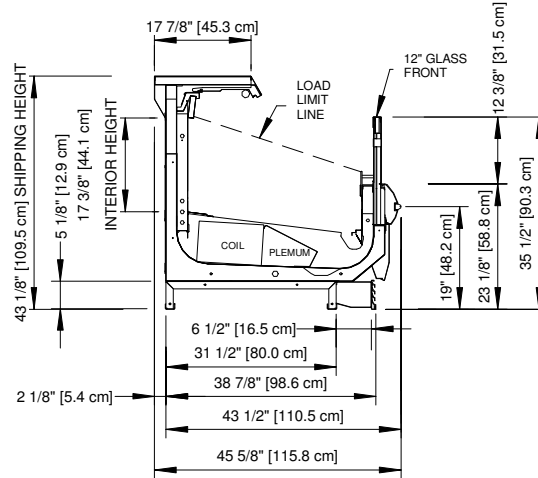

**NOTES:**

- \* : STUB-UP AREA
- \*\* : RECOMMENDED STUB-UP CENTERLINE FOR ELECTRICAL AND HUB DRAINS
- Front and rear sill heights vary with base frame height.
- Ends add approximately 1" to case height.
- Dashed lines signify area inside the base rail behind the kick plate.



ALL MEASUREMENTS ARE TAKEN PER ASHRAE-72-2005 SPECIFICATIONS. HILLPHOENIX REFRIGERATED DISPLAY CASES FOR SALE IN THE UNITED STATES MEET OR EXCEED DEPARTMENT OF ENERGY 2017 REQUIREMENTS.

**O2MZD**

Rev. Date	Rev. #	Rev. Title
12-16-21	4	DATA UPDATE
9-12-18	3	DATA UPDATE

