

# OHPH-NRG

4', 6', 8' & 12' High Multi-Deck Merchandiser with Synerg-E™  
Bulk Produce/Bakery/Dairy/Cut Produce

**GENERAL NOTES:**

- "---" indicates that the feature is not an option on this case model and/or the data is not available at this time.
- LED lights only.

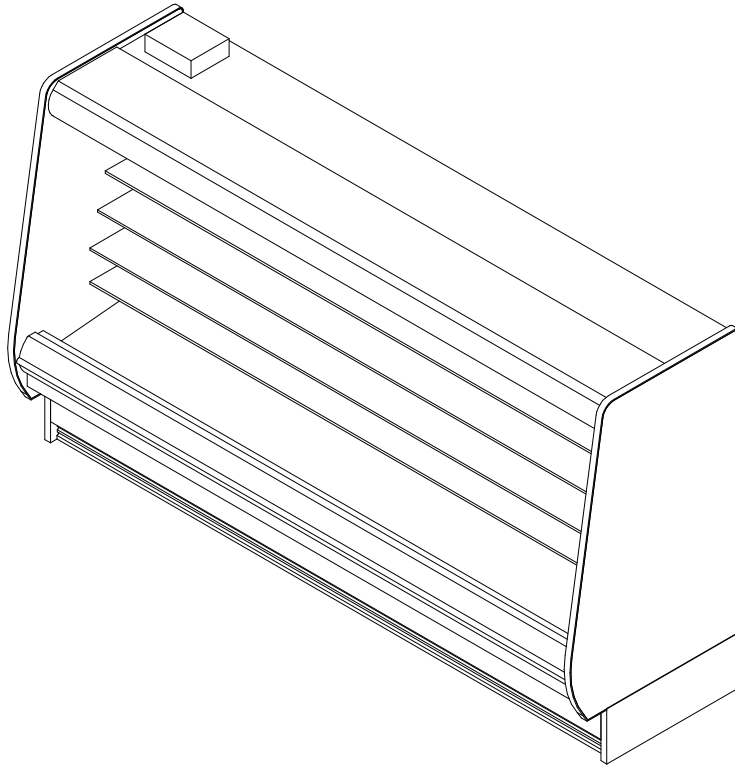

SHIPPING WEIGHT	
Case	Weight
OHPH-NRG	---



ALL MEASUREMENTS ARE TAKEN PER ASHRAE-72 SPECIFICATIONS. HILLPHOENIX REFRIGERATED DISPLAY CASES FOR SALE IN THE UNITED STATES MEET OR EXCEED DEPARTMENT OF ENERGY 2017 REQUIREMENTS.

**OHPH-NRG**

Rev. Date	Rev. #	Rev. Title
07-15-21	7	ENDVIEW UPDATE
09-25-19	6	OPTIONS UPDATE



# OHPH-NRG

4', 6', 8' & 12' High Multi-Deck Merchandiser with Synerg-E™  
Bulk Produce/Bakery/Dairy/Cut Produce

ELECTRICAL DATA			
Case Length	Fans Per Case	High Efficiency Fans	
		120 Volt	
		Amps	Watts
4'	1	0.23	18.0
6'	2	0.47	35.0
8'	3	0.70	53.0
12'	4	0.93	71.0

LIGHTING DATA						
Case Length	Lights per row	Lights Length	Clearvoyant v4 LED Lighting (Per Light Row)			
			Standard Power (Cornice or Shelf)		High Power (Cornice Only)	
			120 Volts		120 Volts	
			Amps	Watts	Amps	Watts
4'	1	4'	0.05	5.9	0.12	14.9
6'	2	3'	0.08	9.4	0.20	23.8
8'	2	4'	0.10	11.8	0.25	29.9
12'	3	4'	0.15	17.6	0.37	44.8

GUIDELINES AND CONTROL SETTINGS						
Application	BTUH/ft		Superheat Set Point @ Bulb (°F)	Evaporator (°F)	Discharge Air (°F)	Discharge Air Velocity (FPM)
	Conventional	Parallel				
Bakery/Dairy/Cut Produce	1263	1105	6 - 8	32	36	150
Bulk Produce	1177	1030	6 - 8	34	38	150

DEFROST CONTROLS		
Defrosts Per Day	Timed-Off Defrost	
	Fail-Safe (Min)	Termination Temp (°F)
6	40	47

## NOTES:

- "-" indicates that the feature is not an option on this case model and/or the data is not available at this time.
- Listed BTUH/ft data represent unlighted shelves. For LED lighting, add 9 BTUH/ft per row of lighted shelving.
- BTUH load increases by 132 BTUH/ft when aftermarket merchandising accessories are utilized.
- Listed evaporator temperature represents unlighted shelves. For lighted shelves and/or aftermarket merchandising accessories, reduce the listed evaporator temperature by 2°F.
- Conventional Discharge Air Control – Recommended Settings: Cut-In Temp = Discharge Air + 2°F; Cut-Out Temp = Discharge Air - 2°F.
- Listed discharge air velocity represents the average velocity immediately after defrost.
- Temperature and defrost settings listed above are recommended start-up settings. Final operational settings may need to be adjusted for the store conditions in which the case operates.
- The recommended evaporator temperatures may need to be adjusted based on system setup, store conditions, etc. The minimum recommended evaporator temperature is 4°F below the listed evaporator temperature.



ALL MEASUREMENTS ARE TAKEN PER ASHRAE-72 SPECIFICATIONS. HILLPHOENIX REFRIGERATED DISPLAY CASES FOR SALE IN THE UNITED STATES MEET OR EXCEED DEPARTMENT OF ENERGY 2017 REQUIREMENTS.

## OHPH-NRG

Rev. Date	Rev. #	Rev. Title
07-15-21	7	ENDVIEW UPDATE
09-25-19	6	OPTIONS UPDATE

**Hillphoenix**  
A DOVER COMPANY

# OHPH-NRG

4', 6', 8' & 12' High Multi-Deck Merchandiser with Synerg-E™  
Bulk Produce/Bakery/Dairy/Cut Produce

SECOND NATURE DATA								
Case Model	No. of Coils	Application	Front Sill height	BTUH/FT		GPM/ft (DR)	Supply Fluid Temp (°F)	Discharge Air Temp (°F)
				Conventional	Parallel			
OHPH-NRG	1	Cut Produce	Standard	1263	1105	0.32	20	30
OHPH-NRG	1	Bulk Produce	Standard	1177	1030	0.14	20	34
OHPH-NRG	1	Cut Produce	Standard	1263	1105	0.58	25	30
OHPH-NRG	1	Bulk Produce	Standard	1177	1030	0.25	25	34

SECOND NATURE DATA									
Case Model	No. of Coils	Application	Front Sill height	Supply Fluid Temp (°F)	No. of Defrost	Timed-Off Defrost		Warm Fluid Defrost	
						Fail-Safe (Min)	Termination Temp (°F)	Fail-Safe (Min)	Termination Temp (°F)
OHPH-NRG	1	Cut Produce	Standard	20	4	60	47	26	49
OHPH-NRG	1	Bulk Produce	Standard	20	4	60	47	26	49
OHPH-NRG	1	Cut Produce	Standard	25	4	45	47	26	49
OHPH-NRG	1	Bulk Produce	Standard	25	4	45	47	26	49

**NOTES:**

- Front sill height and overall case height varies with base frame height.



ALL MEASUREMENTS ARE TAKEN PER ASHRAE-72 SPECIFICATIONS. HILLPHOENIX REFRIGERATED DISPLAY CASES FOR SALE IN THE UNITED STATES MEET OR EXCEED DEPARTMENT OF ENERGY 2017 REQUIREMENTS.

## OHPH-NRG

Rev. Date	Rev. #	Rev. Title
07-15-21	7	ENDVIEW UPDATE
09-25-19	6	OPTIONS UPDATE



A DOVER COMPANY

# OHPH-NRG

4', 6', 8' & 12' High Multi-Deck Merchandiser with Synerg-E™  
Bulk Produce/Bakery/Dairy/Cut Produce

FRONT OPTIONS	CORNICHE OPTIONS						
	CURVED CORNICE 34 3/4"	CURVED CORNICE WITH NIGHT COVER 38"	FACETED CORNICE 34 5/8"	FACETED CORNICE WITH NIGHT COVER 37 7/8"	FLAT CORNICE 33 7/8"	FLAT CORNICE WITH STANDARD NIGHT COVER 36 1/2"	
FRONT OPTIONS	FLAT FRONT 2	STANDARD FRONT 1" BASEFRAME: 28 1/8" [71.5 cm] 5" BASEFRAME: 22 3/8" [56.7 cm]		EXTENDED STANDARD FRONT 1" BASEFRAME: 33 1/8" [84.0 cm] 5" BASEFRAME: 27" [68.6 cm]		6" THERMOPANE FRONT 1" BASEFRAME: 33 3/8" [84.9 cm] 5" BASEFRAME: 27 3/8" [69.5 cm]	
	FLAT FRONT	STANDARD FRONT 1" BASEFRAME: 27" [68.7 cm] 5" BASEFRAME: 21 1/8" [53.8 cm]		EXTENDED STANDARD FRONT 1" BASEFRAME: 30" [76.2 cm] 5" BASEFRAME: 24 1/8" [61.3 cm]		6" THERMOPANE FRONT 1" BASEFRAME: 33 1/8" [84.1 cm] 5" BASEFRAME: 27 1/4" [69.1 cm]	
	CLASSIC 2 METAL	STANDARD FRONT 1" BASEFRAME: 27" [68.7 cm] 5" BASEFRAME: 21 1/8" [53.7 cm]		EXTENDED STANDARD FRONT 1" BASEFRAME: 30" [76.2 cm] 5" BASEFRAME: 24 1/8" [61.3 cm]		6" THERMOPANE FRONT 1" BASEFRAME: 33 1/8" [84.2 cm] 5" BASEFRAME: 27 1/4" [69.3 cm]	
	CLASSIC 2 POLYMER	STANDARD FRONT 1" BASEFRAME: 27" [68.7 cm] 5" BASEFRAME: 21 1/8" [53.7 cm]		EXTENDED STANDARD FRONT 1" BASEFRAME: 30" [76.2 cm] 5" BASEFRAME: 24 1/8" [61.3 cm]		6" THERMOPANE FRONT 1" BASEFRAME: 33 1/8" [84.2 cm] 5" BASEFRAME: 27 1/4" [69.3 cm]	
	ORIGIN 2	STANDARD FRONT 1" BASEFRAME: 27" [68.7 cm] 5" BASEFRAME: 21 1/8" [53.8 cm]		EXTENDED STANDARD FRONT 1" BASEFRAME: 30" [76.2 cm] 5" BASEFRAME: 24 1/8" [61.3 cm]		6" THERMOPANE FRONT 1" BASEFRAME: 33 1/8" [84.2 cm] 5" BASEFRAME: 27 1/4" [69.3 cm]	

**NOTES:**

- Front sill height and overall case height varies with base frame height.



ALL MEASUREMENTS ARE TAKEN PER ASHRAE-72 SPECIFICATIONS. HILLPHOENIX REFRIGERATED DISPLAY CASES FOR SALE IN THE UNITED STATES MEET OR EXCEED DEPARTMENT OF ENERGY 2017 REQUIREMENTS.

**OHPH-NRG**

Rev. Date	Rev. #	Rev. Title
07-15-21	7	ENDVIEW UPDATE
09-25-19	6	OPTIONS UPDATE



# OHPH-NRG

4', 6', 8' & 12' High Multi-Deck Merchandiser with Synerg-E™  
Bulk Produce/Bakery/Dairy/Cut Produce

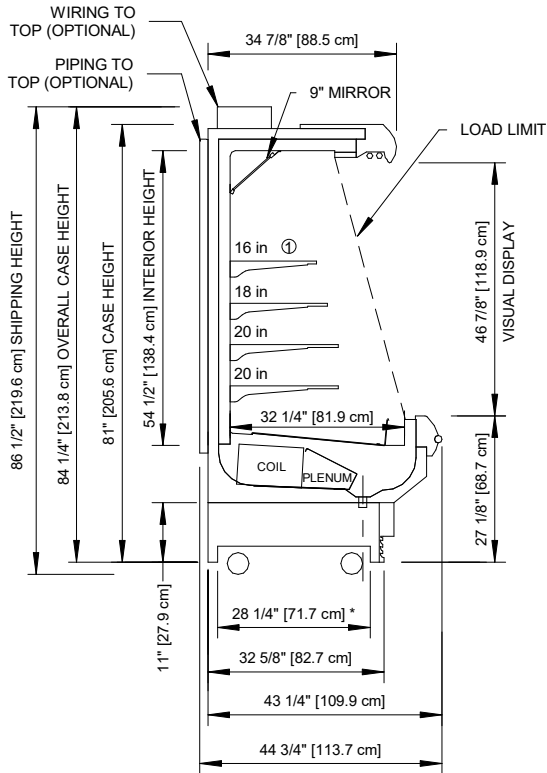

**11" BASEFRAME**

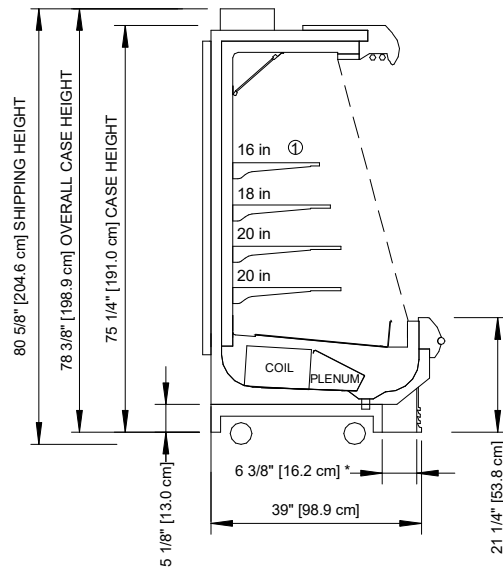

**5" BASEFRAME**

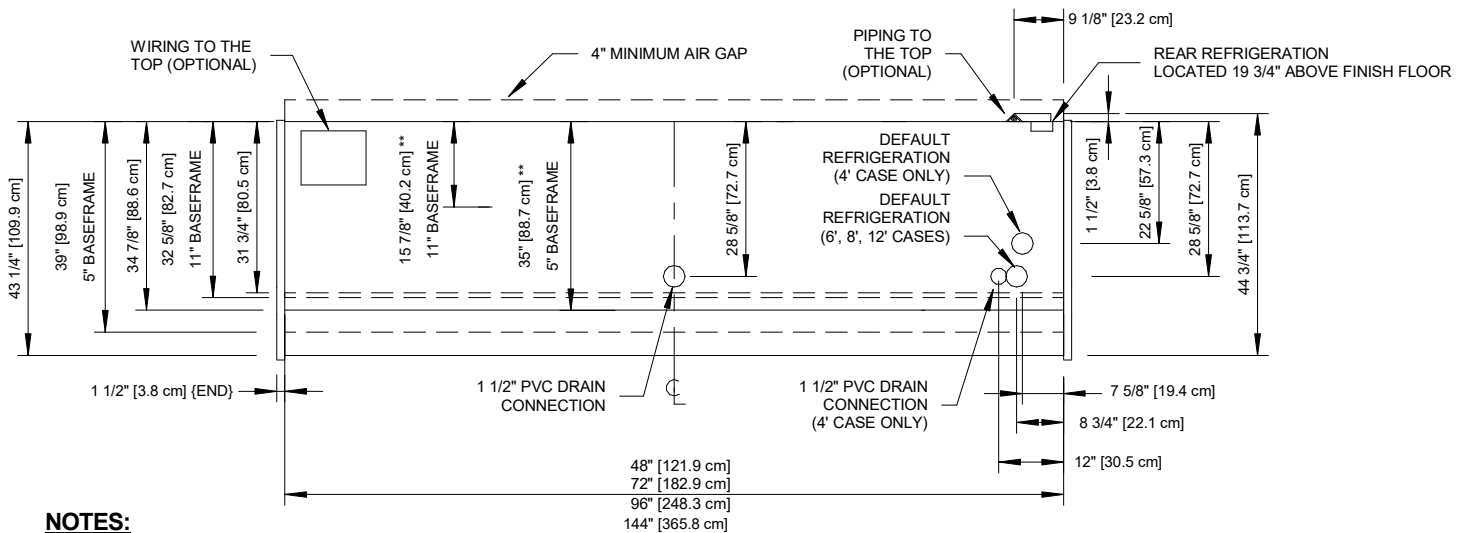

**NOTES:**

\* :STUB-UP AREA

\*\* :RECOMMENDED STUP-UP CENTERLINE FOR ELECTRICAL AND DRAINS

① :AVAILABLE SHELF SIZES: 16", 18", & 20" Articulating or 14", 16", 18", 20", 22" & 24" Standard;(5) ROWS OF SHELVES MAX.

- Ends add approximately 1" to case height, 1/2" to the back & 1" to the front.
- Back panels add approximately 1" to the rear of the case.



OHPH-NRG

ALL MEASUREMENTS ARE TAKEN PER ASHRAE-72 SPECIFICATIONS. HILLPHOENIX REFRIGERATED DISPLAY CASES FOR SALE IN THE UNITED STATES MEET OR EXCEED DEPARTMENT OF ENERGY 2017 REQUIREMENTS.

Rev. Date	Rev. #	Rev. Title
07-15-21	7	ENDVIEW UPDATE
09-25-19	6	OPTIONS UPDATE

