

ONIZGGQA

8', & 12' Low Temp Island Merchandiser
Frozen Food

SOLOCHILL
MICRO-DISTRIBUTED

GENERAL NOTES

- "----" indicates the feature is not an option for this model and/or the data is not yet available.

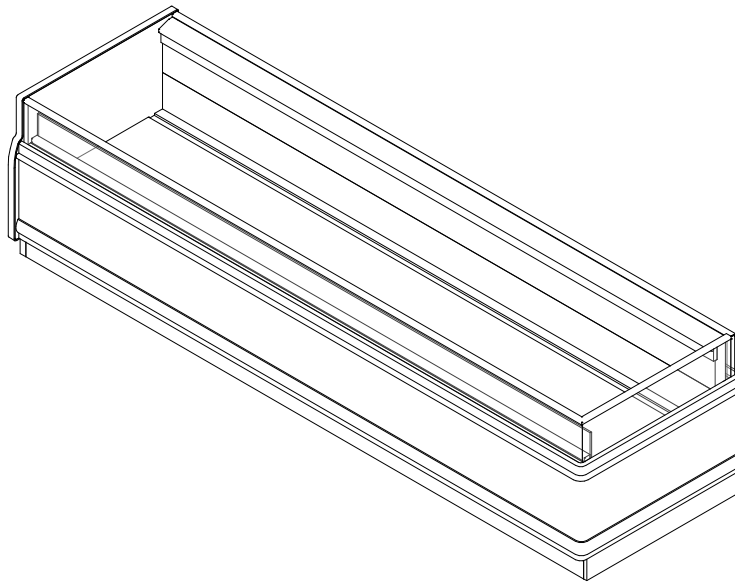

SHIPPING WEIGHT	
Case	Weight
ONIZGGQA	----



ALL MEASUREMENTS ARE TAKEN PER ASHRAE-72-2005 SPECIFICATIONS. HILLPHOENIX REFRIGERATED DISPLAY CASES FOR SALE IN THE UNITED STATES MEET OR EXCEED DEPARTMENT OF ENERGY 2017 REQUIREMENTS.

ONIZGGQA

Rev. Date	Rev. #	Rev. Title
8-10-20	2	SOLOCHILL V5
4-7-20	1	OPTIONS UPDATE

Hillphoenix
A DOVER COMPANY

ONIZGGQA

8', & 12' Low Temp Island Merchandiser
Frozen Food

SOLOCHILL
MICRO-DISTRIBUTED

ELECTRICAL DATA											
Case Length	Fans Per Case	High Efficiency Fans		Anti Condensate Heaters		Drain Heater		Defrost Heaters			
		120 Volt		120 Volts		120 Volts		208 Volts		240 Volts	
		Amps	Watts	Amps	Watts	Amps	Watts	Amps	Watts	Amps	Watts
8'	3	0.45	33	2.54	305	0.13	15	11.55	2400	13.32	3195
12'	4	0.60	44	3.48	417	0.13	15	1500	3600	19.98	4795

DEFROST CONTROLS				
Application	Defrosts Per Day	Run Off Time (Min)	Electric Defrost	
			Fail-Safe (Min)	Termination Temp (°F)
Frozen Food	2	13 - 15	35	47
Medium Temp	2	13 - 15	18	47



ALL MEASUREMENTS ARE TAKEN PER ASHRAE-72-2005 SPECIFICATIONS. HILLPHOENIX REFRIGERATED DISPLAY CASES FOR SALE IN THE UNITED STATES MEET OR EXCEED DEPARTMENT OF ENERGY 2017 REQUIREMENTS.

ONIZGGQA

Rev. Date	Rev. #	Rev. Title
8-10-20	2	SOLOCHILL V5
4-7-20	1	OPTIONS UPDATE

Hillphoenix
A DOVER COMPANY

ONIZGGQA

8', & 12' Low Temp Island Merchandiser
Frozen Food



SOLOCHILL DATA			@95° Condensing Temperature		
Volts	Phase	Frequency	Wire		
208	1	60	3 Wire + Ground		
Application		Case Length	Evaporator Temp (°F)	Discharge Air (°F)	Discharge Air Velocity (FPM)
Frozen Food		8'	-22	-10	255
Frozen Food		12'	-22	-10	255

Application	Case Length	R448A					
		Condensing Unit Model	MCA	MOP	Required Capacity	THR (BTUH)	Flow Rate
Frozen Food	8'	DA330	26.9	30	4424	7342	2.1
Frozen Food	12'	DA420	38.1	40	6636	10637	3.0



ALL MEASUREMENTS ARE TAKEN PER ASHRAE-72-2005 SPECIFICATIONS. HILLPHOENIX REFRIGERATED DISPLAY CASES FOR SALE IN THE UNITED STATES MEET OR EXCEED DEPARTMENT OF ENERGY 2017 REQUIREMENTS.

ONIZGGQA

Rev. Date	Rev. #	Rev. Title
8-10-20	2	SOLOCHILL V5
4-7-20	1	OPTIONS UPDATE

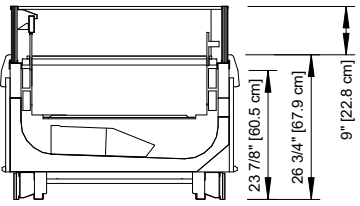
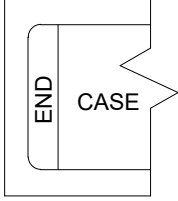
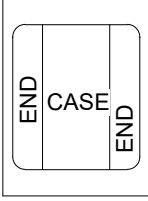
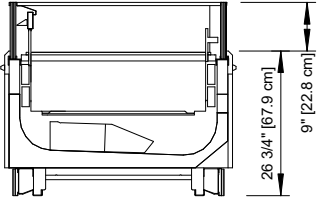
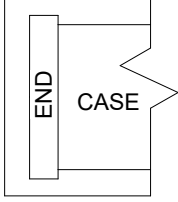
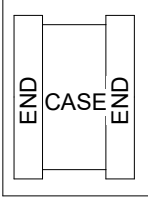
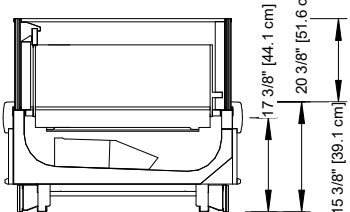
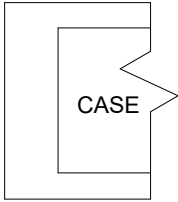
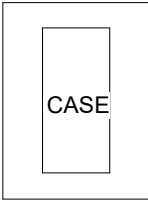
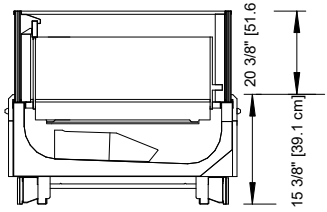
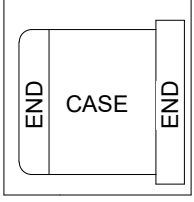

A DOVER COMPANY

GLASS FRONT OPTIONS	END OPTIONS	
<p><u>10" GLASS STREAMLINE FRONT</u></p> 	<p><u>SINGLE WRAP END</u></p> 	<p><u>DOUBLE WRAP END</u></p> 
<p><u>10" GLASS FLAT FRONT</u></p> 	<p><u>SINGLE FLAT END</u></p> 	<p><u>DOUBLE FLAT END</u></p> 
<p><u>17" GLASS STREAMLINE FRONT</u></p> 	<p><u>SINGLE JOINT (BUTT)</u></p> 	<p><u>DOUBLE JOINT (BUTT)</u></p> 
<p><u>17" GLASS FLAT FRONT</u></p> 	<p><u>SINGLE WRAP SINGLE FLAT END</u></p> 	



ALL MEASUREMENTS ARE TAKEN PER ASHRAE-72-2005 SPECIFICATIONS. HILLPHOENIX REFRIGERATED DISPLAY CASES FOR SALE IN THE UNITED STATES MEET OR EXCEED DEPARTMENT OF ENERGY 2017 REQUIREMENTS.

ONIZGGQA

Rev. Date	Rev. #	Rev. Title
8-10-20	2	SOLOCHILL V5
4-7-20	1	OPTIONS UPDATE

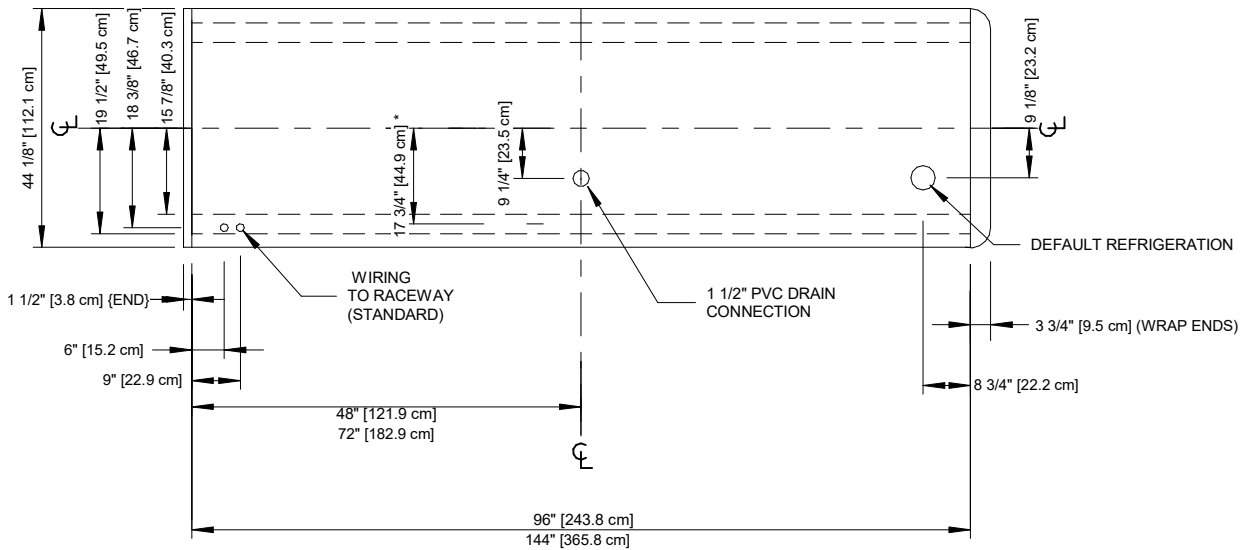
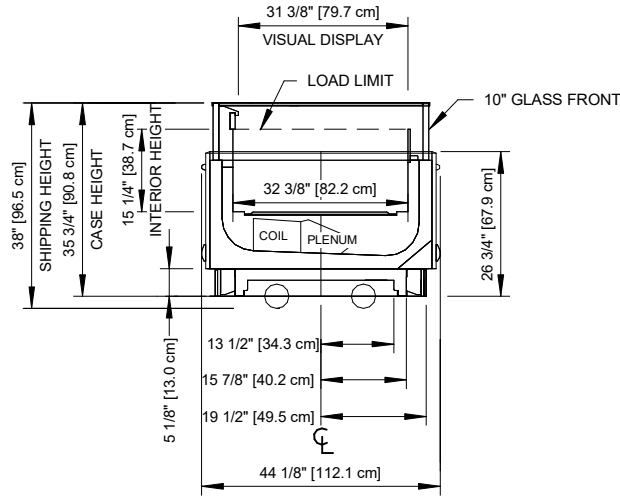

NOTES

- * :STUB-UP AREA
- ** :RECOMMENDED STUB-UP CENTERLINE FOR ELECTRICAL AND HUB DRAINS
- Front and rear sill heights vary with baseframe height.



ALL MEASUREMENTS ARE TAKEN PER ASHRAE-72-2005 SPECIFICATIONS. HILLPHOENIX REFRIGERATED DISPLAY CASES FOR SALE IN THE UNITED STATES MEET OR EXCEED DEPARTMENT OF ENERGY 2017 REQUIREMENTS.

ONIZGGQA

Rev. Date	Rev. #	Rev. Title
8-10-20	2	SOLOCHILL V5
4-7-20	1	OPTIONS UPDATE