

PTD-GSD-R

Self-Service Open Multi-Deck Merchandiser w/ GSD Service Dome & DRS
4', 6', 8', 10' & 12' (Bakery/Beverage/Deli/Meat/Seafood)

GENERAL NOTES:

- "---" Indicates that the feature is not an option on this case model and/or the data is not yet available at this time.
- (DRS) Dry Rear Storage
- (RRS) Refrigerated Rear Storage (optional)

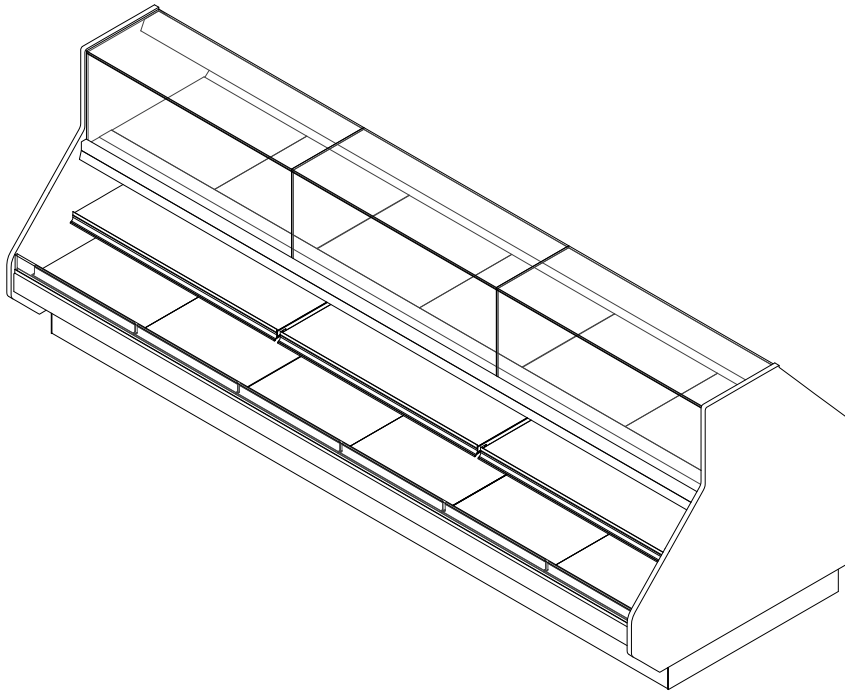

SHIPPING WEIGHT	
Case	Weight
PTD-GSD-R	---



ENGINEERED FOR STORES WITH AMBIENT CONDITIONS NOT TO EXCEED 75° AND 55% RELATIVE HUMIDITY. DUE TO ENGINEERING IMPROVEMENTS SPECIFICATIONS MAY CHANGE WITHOUT NOTICE. ALL MEASUREMENTS ARE TAKEN PER ASHRAE-72 SPECIFICATIONS. HILLPHOENIX REFRIGERATED DISPLAY CASES FOR SALE IN THE UNITED STATES MEET OR EXCEED DEPARTMENT OF ENERGY 2017 REQUIREMENTS. NUMBERS ARE BASED ON STANDARD CASE SIZES. CONSULT ENGINEERING.

PTD-GSD-R

Rev. Date	Rev. #	Rev. Title
06-28-21	1	NEW STANDARDS



ELECTRICAL DATA (DOME)											
Case Length	Fans Per Case	Box Fans		High Efficiency Fans		Anti-Condensate Heaters		Drain Heaters		Optional Defrost Heaters	
		120 Volts		120 Volts		120 Volts		120 Volts		208 Volts	
		Amps	Watts	Amps	Watts	Amps	Watts	Amps	Watts	Amps	Watts
4'	1	0.13	15.6	---	---	0.17	20.4	---	---	---	---
6'	2	0.26	31.2	---	---	0.31	37.2	---	---	---	---
8'	3	0.39	46.8	---	---	0.42	50.4	---	---	---	---
10'	4	0.52	62.4	---	---	0.52	62.4	---	---	---	---
12'	4	0.52	62.4	---	---	0.62	74.4	---	---	---	---

ELECTRICAL DATA (BASE)												
Case Length	Fans Per Case	High Efficiency Fans		Anti-Condensate Heaters		Drain Heaters		Optional Defrost Heaters		RRS		
		120 Volts		120 Volts		120 Volts		208 Volts		Fans Per Case	Unit Cooler Fans	
		Amps	Watts	Amps	Watts	Amps	Watts	Amps	Watts		120 Volts	
		Amps	Watts	Amps	Watts	Amps	Watts	Amps	Watts	Amps	Watts	
4'	1	0.30	36	---	---	---	---	---	---	---	---	---
6'	2	0.60	72	---	---	---	---	---	---	---	---	---
8'	3	0.90	108	---	---	---	---	---	---	---	---	---
10'	4	1.20	144	---	---	---	---	---	---	---	---	---
12'	4	1.20	144	---	---	---	---	---	---	---	---	---

LIGHTING DATA						
Case Length	Lights Per Row	Light Length	Clearvoyant 4 LED Lighting (Per Light Row)			
			Standard Power (Cornice or Shelf)		High Power (Cornice)	
			120 Volts		120 Volts	
			Amps	Watts	Amps	Watts
4'	1	4'	0.05	5.9	0.12	14.9
6'	2	3'	0.08	9.4	0.20	23.8
8'	2	4'	0.10	11.8	0.24	29.8
10'	2	5'	0.12	15.0	0.30	37.0
12'	3	4'	0.15	17.7	0.36	44.7

- NOTES:**
- "—" Indicates that the feature is not an option on this case model and/or the data is not yet available at this time.
 - RRS - Refrigerated Rear Storage.
 - Listed BTUH indicates unlighted shelves. Add the following for lighted shelves:
4' Shelf LED: 36 BTUH
4' Canopy LED: 72 BTUH
3' Shelf LED: 27 BTUH
3' Hi-Output LED: 54 BTUH
 - Listed discharge air velocity represents the average velocity at the peak of defrost.
 - Discharge air temperature values represent readings taken within the upper air channel immediately behind/upstream of the honeycomb.
 - * Time-off duration for defrost with no termination control.



ENGINEERED FOR STORES WITH AMBIENT CONDITIONS NOT TO EXCEED 75° AND 55% RELATIVE HUMIDITY. DUE TO ENGINEERING IMPROVEMENTS SPECIFICATIONS MAY CHANGE WITHOUT NOTICE. ALL MEASUREMENTS ARE TAKEN PER ASHRAE-72 SPECIFICATIONS. HILLPHOENIX REFRIGERATED DISPLAY CASES FOR SALE IN THE UNITED STATES MEET OR EXCEED DEPARTMENT OF ENERGY 2017 REQUIREMENTS. NUMBERS ARE BASED ON STANDARD CASE SIZES. CONSULT ENGINEERING.

PTD-GSD-R

Rev. Date	Rev. #	Rev. Title
06-28-21	1	NEW STANDARDS



GUIDELINES AND CONTROL SETTINGS (DX) {DIRECT EXPANSION HFC/CO2}						
	BTUH/ft		Superheat Set Point @ Bulb (°F)	Evaporator (°F)	Discharge Air (°F)	Discharge Air Velocity (FPM)
	Conventional	Parallel				
Dome	272	250	10	26	29	150
Base	485	445	6 - 8	26	29	250
RRS	109	100	10	26	29	200

DEFROST CONTROLS {DIRECT EXPANSION HFC/CO2}								
	Defrosts Per Day	Run-Off Time (Min)	Electric Defrost		Timed-Off Defrost		Hot Gas Defrost	
			Fail-Safe (Min)	Termination Temp (°F)	Fail-Safe (Min)	Termination Temp (°F)	Fail-Safe (Min)	Termination Temp (°F)
Dome	4	---	---	---	65/*36	42	---	---
Base	4	---	---	---	65/*36	42	---	---
RRS	4	---	---	---	65/*36	42	---	---



ENGINEERED FOR STORES WITH AMBIENT CONDITIONS NOT TO EXCEED 75° AND 55% RELATIVE HUMIDITY. DUE TO ENGINEERING IMPROVEMENTS SPECIFICATIONS MAY CHANGE WITHOUT NOTICE. ALL MEASUREMENTS ARE TAKEN PER ASHRAE-72 SPECIFICATIONS. HILLPHOENIX REFRIGERATED DISPLAY CASES FOR SALE IN THE UNITED STATES MEET OR EXCEED DEPARTMENT OF ENERGY 2017 REQUIREMENTS. NUMBERS ARE BASED ON STANDARD CASE SIZES. CONSULT ENGINEERING.

PTD-GSD-R

Rev. Date	Rev. #	Rev. Title
06-28-21	1	NEW STANDARDS



PTD-GSD-R

Self-Service Open Multi-Deck Merchandising Dome & DRS
4', 6', 8', 10' & 12' (Bakery/Beverage/Deli/Meat/Seafood)

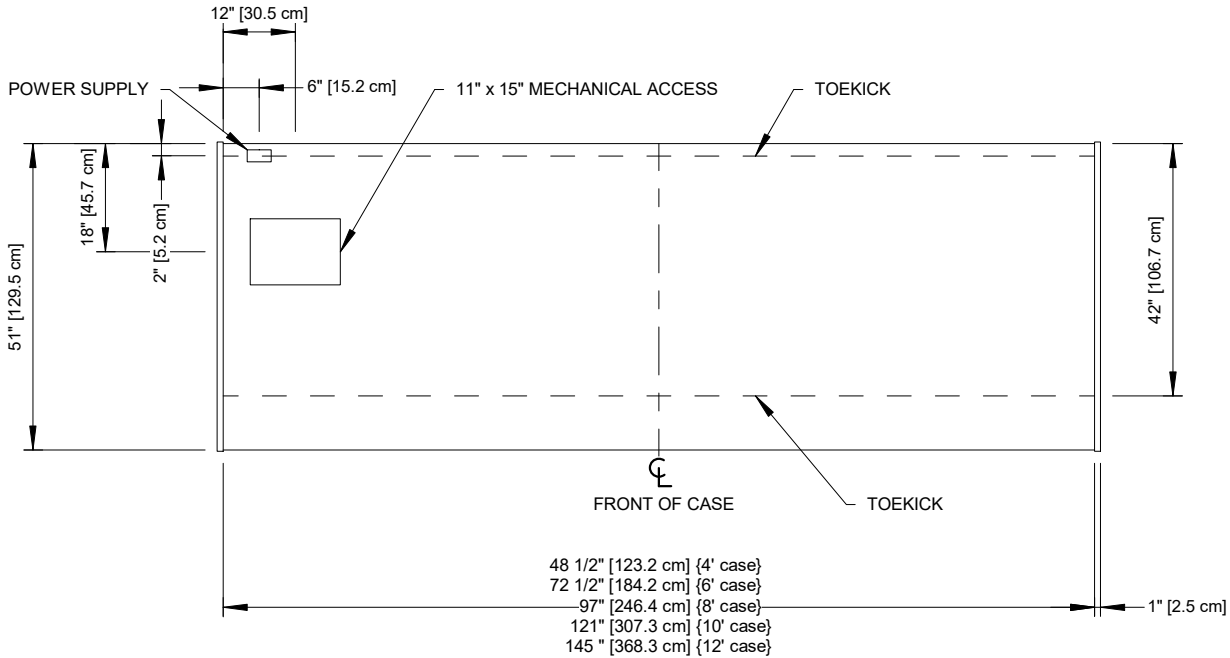
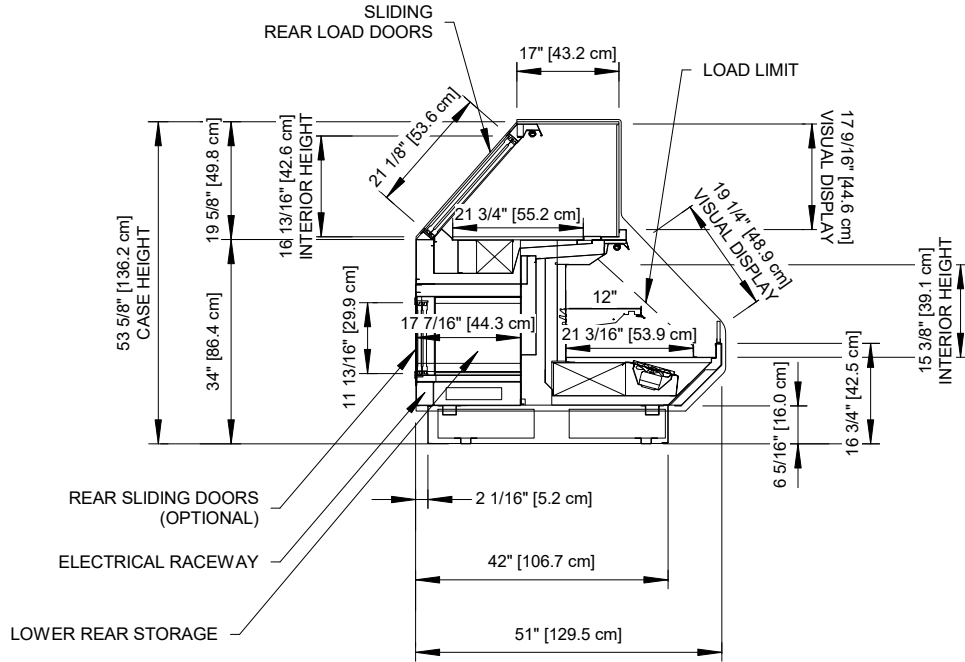

2017
DOE
COMPLIANT



Intertek



Intertek

ENGINEERED FOR STORES WITH AMBIENT CONDITIONS NOT TO EXCEED 75° AND 55% RELATIVE HUMIDITY. DUE TO ENGINEERING IMPROVEMENTS SPECIFICATIONS MAY CHANGE WITHOUT NOTICE. ALL MEASUREMENTS ARE TAKEN PER ASHRAE-72 SPECIFICATIONS. HILLPHOENIX REFRIGERATED DISPLAY CASES FOR SALE IN THE UNITED STATES MEET OR EXCEED DEPARTMENT OF ENERGY 2017 REQUIREMENTS. NUMBERS ARE BASED ON STANDARD CASE SIZES. CONSULT ENGINEERING.

PTD-GSD-R

Rev. Date	Rev. #	Rev. Title
06-28-21	1	NEW STANDARDS

Clearvoyant
LED SYSTEM

Hillphoenix

a DOVER company