

# S2SG-R

Service Single-Deck Merchandiser w/ Flat Lift Glass  
4', 6', 8', 10' & 12' (Deli, Meat & Seafood)

## GENERAL NOTES:

- "---" Indicates that the feature is not an option on this case model and/or the data is not yet available at this time.

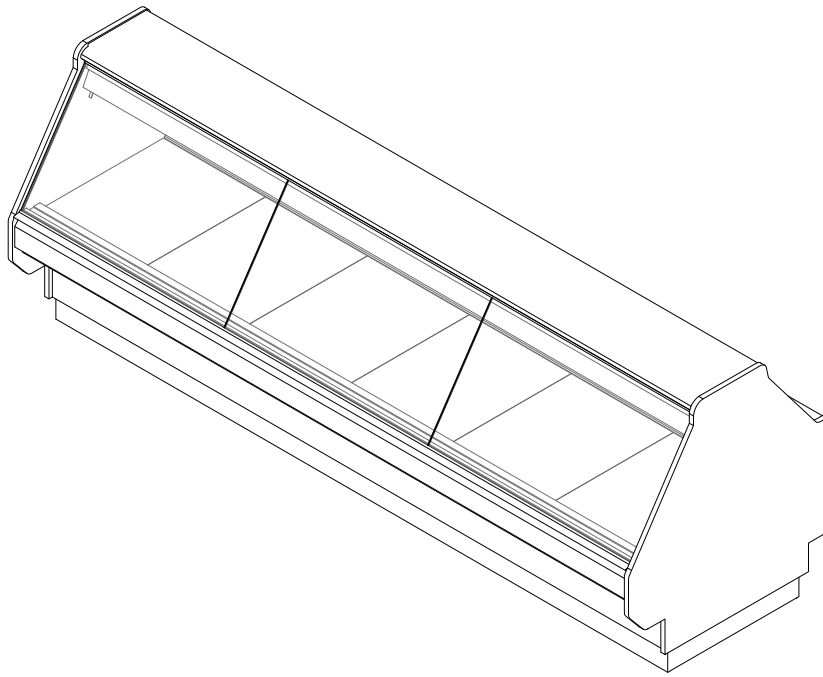

SHIPPING WEIGHT	
Case	Weight
S2SG-R	---



## S2SG-R

Rev. Date	Rev. #	Rev. Title
03-10-22	3	DATA UPDATE
07-09-21	2	APP UPDATE



ALL MEASUREMENTS ARE TAKEN PER ASHRAE-72 SPECIFICATIONS. HILLPHOENIX REFRIGERATED DISPLAY CASES FOR SALE IN THE UNITED STATES MEET OR EXCEED DEPARTMENT OF ENERGY 2017 REQUIREMENTS.

ELECTRICAL DATA											
Case Length	Fans Per Case	High Efficiency Fans		Anti-Condensate Fans		Drain Heaters		Optional Defrost Heaters			
		120 Volts		120 Volts		120 Volts		208 Volts		240 Volts	
		Amps	Watts	Amps	Watts	Amps	Watts	Amps	Watts	Amps	Watts
4'	---	---	---	---	---	---	---	---	---	---	---
6'	---	---	---	---	---	---	---	---	---	---	---
8'	---	---	---	---	---	---	---	---	---	---	---
10'	---	---	---	---	---	---	---	---	---	---	---
12'	---	---	---	---	---	---	---	---	---	---	---

LIGHTING DATA						
Case Length	Lights Per Row	Light Length	Clearvoyant 4 LED Lighting (Per Light Row)			
			Standard Power (Cornice or Shelf)		High Power (Cornice)	
			120 Volts		120 Volts	
			Amps	Watts	Amps	Watts
4'	1	4'	0.05	5.9	0.12	14.9
6'	2	3'	0.08	9.4	0.20	23.8
8'	2	4'	0.10	11.8	0.24	29.8
10'	2	5'	0.12	15.0	0.30	37.0
12'	3	4'	0.15	17.7	0.36	44.7

GUIDELINES AND CONTROL SETTINGS (DX) {DIRECT EXPANSION HFC/CO2}					
BTUH/ft		Superheat Set Point @ Bulb (°F)	Evaporator (°F)	Discharge Air (°F)	Discharge Air Velocity (FPM)
Conventional	Parallel				
294	270	6 - 8	20	---	---

DEFROST CONTROLS {DIRECT EXPANSION HFC/CO2}							
Defrosts Per Day	Run-Off Time (Min)	Electric Defrost		Timed-Off Defrost		Hot Gas Defrost	
		Fail-Safe (Min)	Termination Temp (°F)	Fail-Safe (Min)	Termination Temp (°F)	Fail-Safe (Min)	Termination Temp (°F)
2	6 - 8	---	---	75	50	---	---

- NOTES:**
- "----" Indicates that the feature is not an option on this case model and/or the data is not yet available at this time.
  - Listed discharge air velocity represents the average velocity at the peak of defrost.
  - Listed data is based on the factory recommended default fresh meat temperature settings.
  - Shelves are not recommended for fresh meat applications.
  - Discharge air temperature values represent readings taken within the upper air channel immediately behind/upstream of the honeycomb.



## S2SG-R



ALL MEASUREMENTS ARE TAKEN PER ASHRAE-72 SPECIFICATIONS. HILLPHOENIX REFRIGERATED DISPLAY CASES FOR SALE IN THE UNITED STATES MEET OR EXCEED DEPARTMENT OF ENERGY 2017 REQUIREMENTS.

Rev. Date	Rev. #	Rev. Title
03-10-22	3	DATA UPDATE
07-09-21	2	APP UPDATE

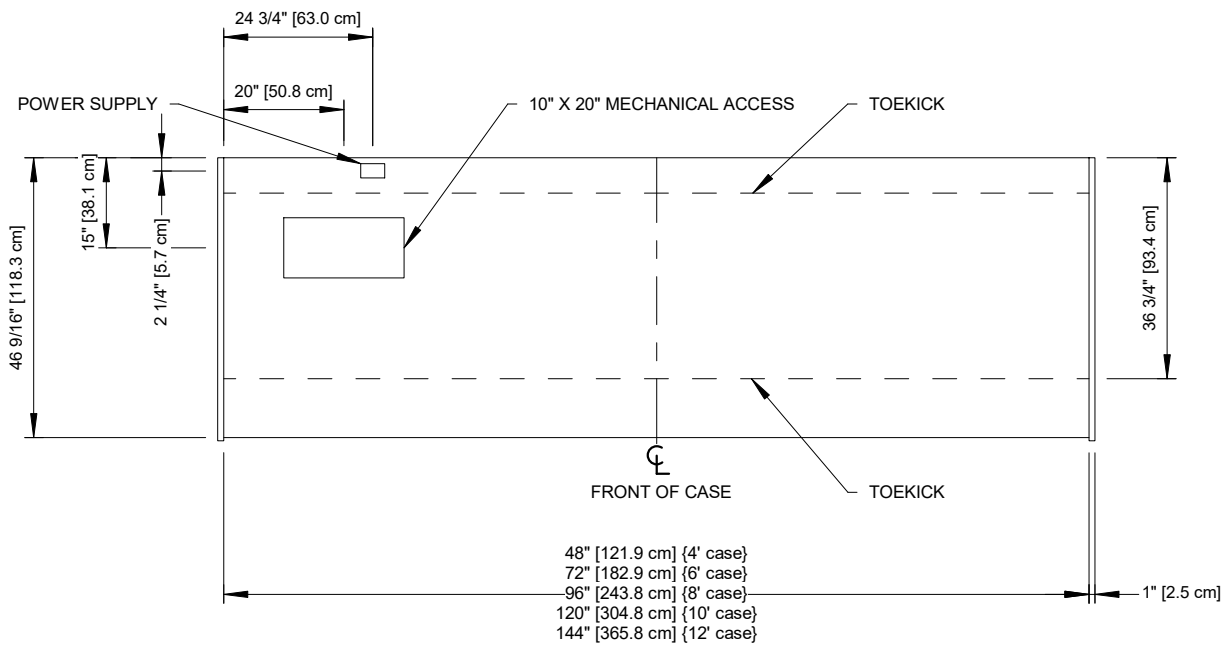
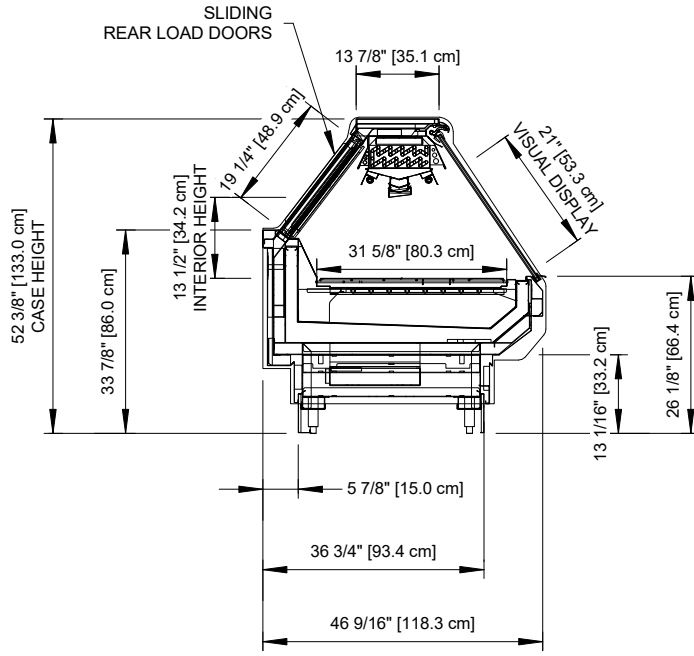

## S2SG-R



ALL MEASUREMENTS ARE TAKEN PER ASHRAE-72 SPECIFICATIONS. HILLPHOENIX REFRIGERATED DISPLAY CASES FOR SALE IN THE UNITED STATES MEET OR EXCEED DEPARTMENT OF ENERGY 2017 REQUIREMENTS.

Rev. Date	Rev. #	Rev. Title
03-10-22	3	DATA UPDATE
07-09-21	2	APP UPDATE