

**GENERAL NOTES:**

- "---" Indicates that the feature is not an option on this case model and/or the data is not yet available at this time.

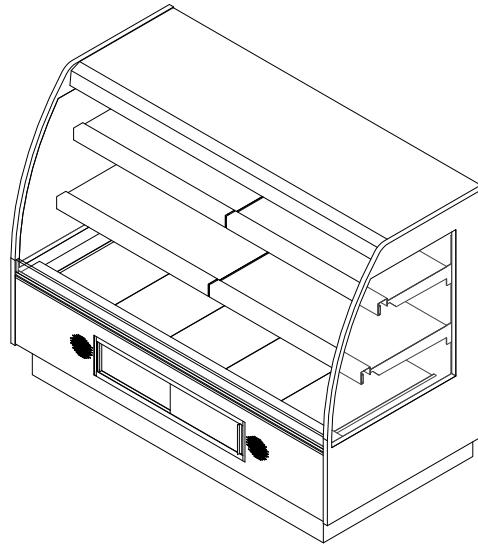

SHIPPING WEIGHT	
Case	Weight
PF-6-H-EC-i2i	---



ENGINEERED FOR STORES WITH AMBIENT CONDITIONS NOT TO EXCEED 75° AND 55% RELATIVE HUMIDITY. DUE TO ENGINEERING IMPROVEMENTS SPECIFICATIONS MAY CHANGE WITHOUT NOTICE. ALL MEASUREMENTS ARE TAKEN PER ASHRAE-72 SPECIFICATIONS. NUMBERS ARE BASED ON STANDARD CASE SIZES. CONSULT ENGINEERING.

**PF-6-H-EC-i2i**

Rev. Date	Rev. #	Rev. Title
02-16-22	1	NEW STANDARDS



# PF-6-H-EC-i2i

SELF-SERVICE DATA													
Case Length	Top Heaters		Bottom Heaters		Lights		Shelves (Per Shelf)				Total Amps (208-3-60)		
	Qty	Watts (Each)	Qty	Watts (Each)	Qty	Watts (Each)	First Shelf		Second Shelf		L1	L2	L3
							Qty	Watts (Each)	Qty	Watts (Each)			
6'	2	43.3	5	400	---	---	2	515	2	680	17.17	18.72	16.05

ELECTRICAL DATA			
Case Length	Fans Per Case	Control Fans	
		208 Volts	
		Amps	Watts
6'	1	.11	22.9

LIGHTING DATA				
Case Length	Lights Per Row	Light Length	Fluorescent Lighting (Per Light Row)	
			Amps	Watts
6'	2	2'	0.30	62.4

**NOTES:**

- "----" Indicates that the feature is not an option on this case model and/or the data is not yet available at this time.



ENGINEERED FOR STORES WITH AMBIENT CONDITIONS NOT TO EXCEED 75° AND 55% RELATIVE HUMIDITY. DUE TO ENGINEERING IMPROVEMENTS SPECIFICATIONS MAY CHANGE WITHOUT NOTICE. ALL MEASUREMENTS ARE TAKEN PER ASHRAE-72 SPECIFICATIONS. NUMBERS ARE BASED ON STANDARD CASE SIZES. CONSULT ENGINEERING.

## PF-6-H-EC-i2i

Rev. Date	Rev. #	Rev. Title
02-16-22	1	NEW STANDARDS



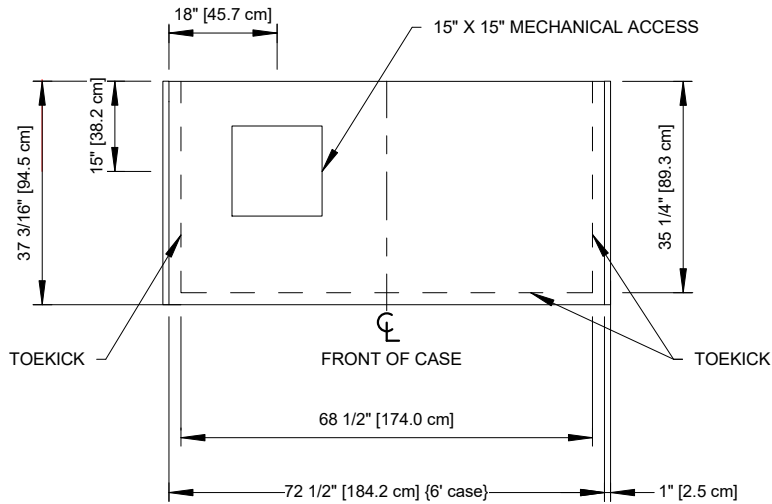
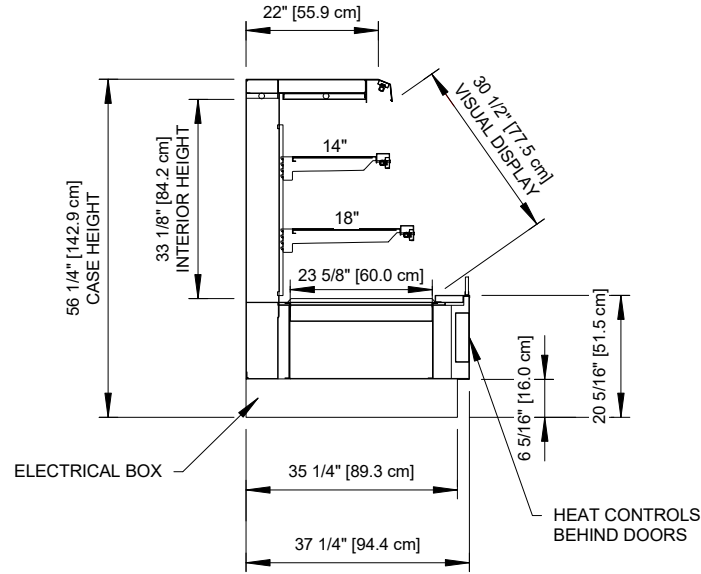

ENGINEERED FOR STORES WITH AMBIENT CONDITIONS NOT TO EXCEED 75° AND 55% RELATIVE HUMIDITY. DUE TO ENGINEERING IMPROVEMENTS SPECIFICATIONS MAY CHANGE WITHOUT NOTICE. ALL MEASUREMENTS ARE TAKEN PER ASHRAE-72 SPECIFICATIONS. NUMBERS ARE BASED ON STANDARD CASE SIZES. CONSULT ENGINEERING.

## PF-6-H-EC-i2i

Rev. Date	Rev. #	Rev. Title
02-16-22	1	NEW STANDARDS

