

PFI-6-R-FLORAL-IC-i2i

Self-Service Open Island Center Merchandiser
4', 6', 8', 10' & 12' (Floral)

GENERAL NOTES:

- "---" Indicates that the feature is not an option on this case model and/or the data is not yet available at this time.

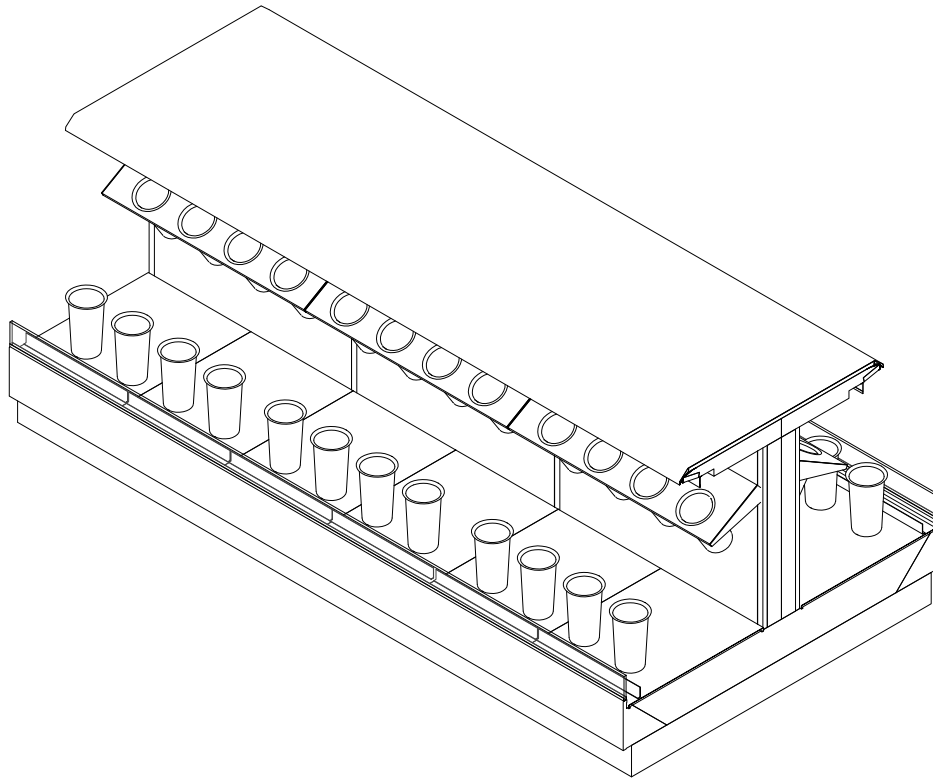

SHIPPING WEIGHT

Case	Weight
PFI-6-R-FLORAL-IC-i2i	---

2017
DOE
COMPLIANT



Intertek



Intertek

ENGINEERED FOR STORES WITH AMBIENT CONDITIONS NOT TO EXCEED 75° AND 55% RELATIVE HUMIDITY. DUE TO ENGINEERING IMPROVEMENTS SPECIFICATIONS MAY CHANGE WITHOUT NOTICE. ALL MEASUREMENTS ARE TAKEN PER ASHRAE-72 SPECIFICATIONS. HILLPHOENIX REFRIGERATED DISPLAY CASES FOR SALE IN THE UNITED STATES MEET OR EXCEED DEPARTMENT OF ENERGY 2017 REQUIREMENTS. NUMBERS ARE BASED ON STANDARD CASE SIZES. CONSULT ENGINEERING.

PFI-6-R-FLORAL-IC-i2i

Rev. Date	Rev. #	Rev. Title
01-12-22	1	NEW STANDARDS



Clearvoyant
LED SYSTEM

Hillphoenix
a **DOVER** company

ELECTRICAL DATA									
Case Length	Fans Per Case	High Efficiency Fans		Anti-Condensate Fans		Drain Heaters		Optional Defrost Heaters	
		120 Volts		120 Volts		120 Volts		208 Volts	
		Amps	Watts	Amps	Watts	Amps	Watts	Amps	Watts
4'	4	1.20	144	---	---	---	---	---	---
6'	6	1.80	216	---	---	---	---	---	---
8'	6	1.80	216	---	---	---	---	---	---
10'	8	2.40	288	---	---	---	---	---	---
12'	8	2.40	288	---	---	---	---	---	---

LIGHTING DATA						
Case Length	Lights Per Row	Light Length	Clearvoyant 4 LED Lighting (Per Light Row)			
			Standard Power (Cornice)		High Power (Cornice)	
			120 Volts		120 Volts	
			Amps	Watts	Amps	Watts
4'	2	4'	0.10	11.8	0.25	29.9
6'	4	3'	0.16	18.8	0.40	47.5
8'	4	4'	0.20	23.5	0.50	59.8
10'	4	5'	0.25	30.1	0.62	73.9
12'	6	4'	0.29	35.3	0.75	89.6

GUIDELINES AND CONTROL SETTINGS {DIRECT EXPANSION HFC/CO2}					
BTUH/ft		Superheat Set Point @ Bulb (°F)	Evaporator (°F)	Discharge Air (°F)	Discharge Air Velocity (FPM)
Conventional	Parallel				
1010	936	10 - 14	24	28	80 - 100

DEFROST CONTROLS {DIRECT EXPANSION HFC/CO2}							
Defrosts Per Day	Run-Off Time (Min)	Electric Defrost		Timed-Off Defrost		Hot Gas Defrost	
		Fail-Safe (Min)	Termination Temp (°F)	Fail-Safe (Min)	Termination Temp (°F)	Fail-Safe (Min)	Termination Temp (°F)
6	30	---	---	---	42	---	---

NOTES:

- "----" Indicates that the feature is not an option on this case model and/or the data is not yet available at this time.
- Discharge air temperature values represent readings taken within the upper air channel immediately behind/upstream of the honeycomb.



ENGINEERED FOR STORES WITH AMBIENT CONDITIONS NOT TO EXCEED 75° AND 55% RELATIVE HUMIDITY. DUE TO ENGINEERING IMPROVEMENTS SPECIFICATIONS MAY CHANGE WITHOUT NOTICE. ALL MEASUREMENTS ARE TAKEN PER ASHRAE-72 SPECIFICATIONS. HILLPHOENIX REFRIGERATED DISPLAY CASES FOR SALE IN THE UNITED STATES MEET OR EXCEED DEPARTMENT OF ENERGY 2017 REQUIREMENTS. NUMBERS ARE BASED ON STANDARD CASE SIZES. CONSULT ENGINEERING.

PFI-6-R-FLOREAL-IC-i2i

Rev. Date	Rev. #	Rev. Title
01-12-22	1	NEW STANDARDS



PFI-6-R-FLOREAL-IC-i2i

Self-Service Open Island Center Merchandiser
4', 6', 8', 10' & 12' (Floral)

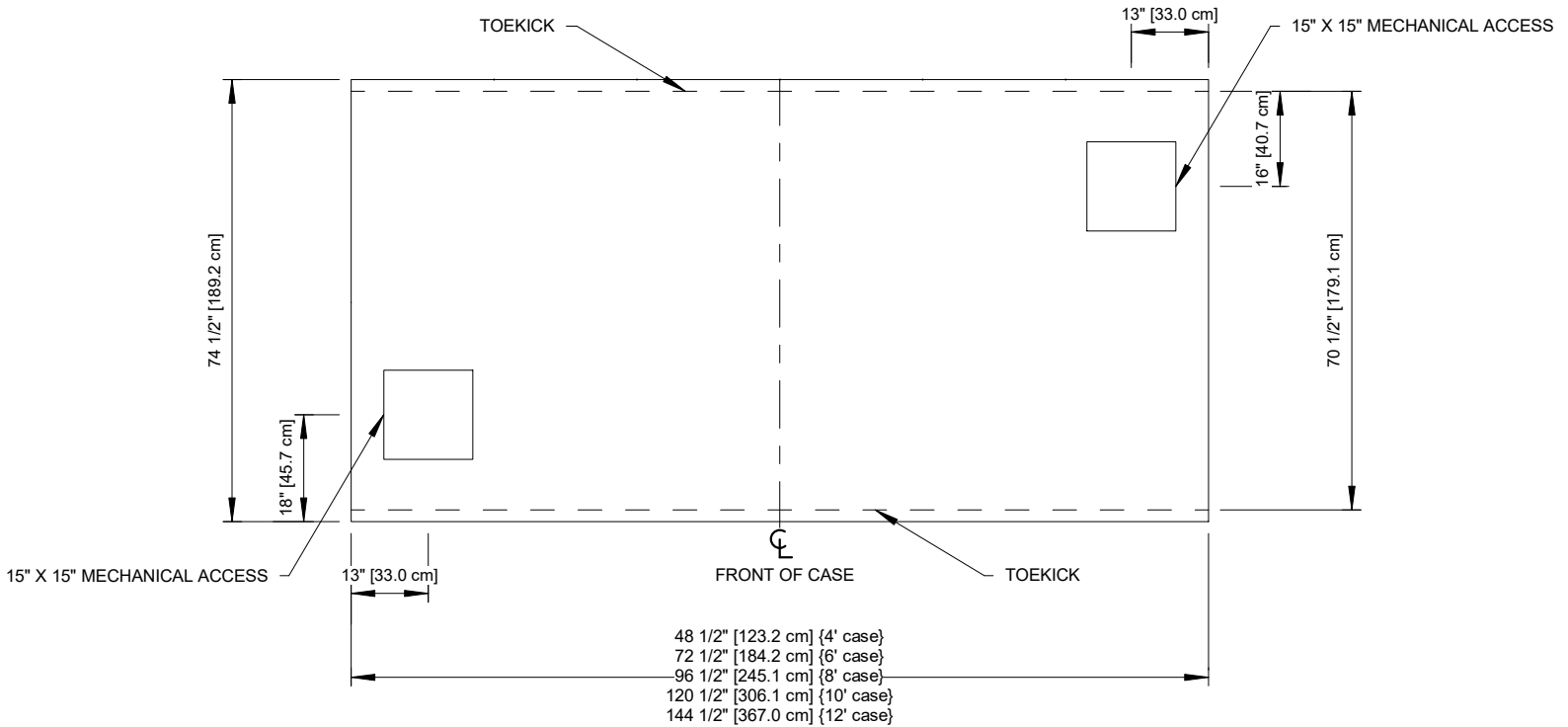
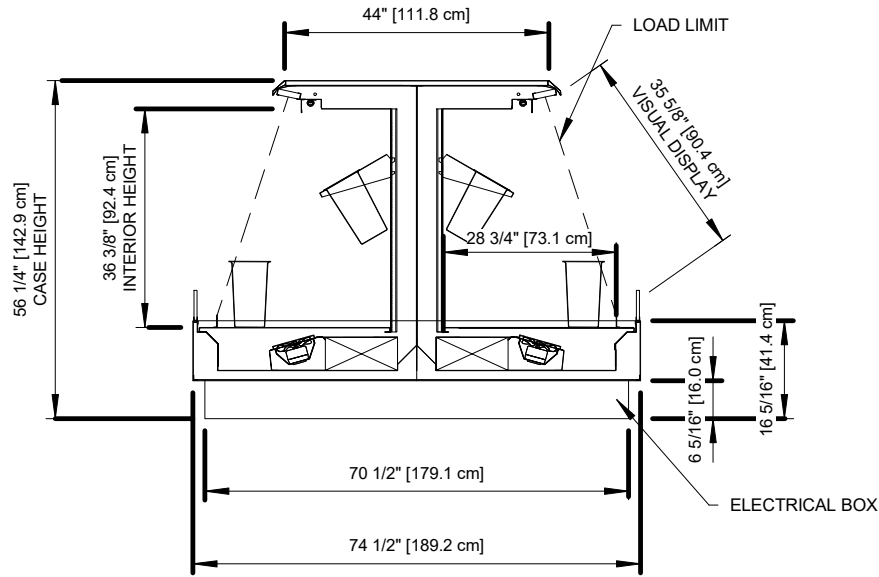

ENGINEERED FOR STORES WITH AMBIENT CONDITIONS NOT TO EXCEED 75° AND 55% RELATIVE HUMIDITY. DUE TO ENGINEERING IMPROVEMENTS SPECIFICATIONS MAY CHANGE WITHOUT NOTICE. ALL MEASUREMENTS ARE TAKEN PER ASHRAE-72 SPECIFICATIONS. HILLPHOENIX REFRIGERATED DISPLAY CASES FOR SALE IN THE UNITED STATES MEET OR EXCEED DEPARTMENT OF ENERGY 2017 REQUIREMENTS. NUMBERS ARE BASED ON STANDARD CASE SIZES. CONSULT ENGINEERING.

PFI-6-R-FLOREAL-IC-i2i

Rev. Date	Rev. #	Rev. Title
01-12-22	1	NEW STANDARDS

