



## Putting a Little Spice Into Life...and Refrigeration

### HPX Industrial Refrigeration and Zone Mechanical Team Up to Spice Things Up

Most of us at one point or another in our lives have heard the saying, “Necessity is the mother of invention.” That “necessity” can come in a wide variety of shapes, forms and sizes. Forty-six years ago, a young engineering graduate student, G.L. Soni, arrived in Fargo, N.D. from the southern India state of Kerala, shocked to find two feet of snow on the ground, not a shred of tandoori in sight, and a mainstream America that was generally clueless when it came to Indian cuisine. “Nobody even knew about yogurt,” he recalls.

His palate craved the foods he was raised on, but to make matters worse, he was clueless himself as to how he would remedy this. Like most Indian men, meals had always “just appeared before him,”

cooked unseen by female or servant hands. In his own words, “I didn’t know a coriander from a cumin seed or a spice from a lentil.”

Upon graduation from school, a civil engineering job brought Soni to New York but did little to quench his insatiable desire and overwhelming need for once again partaking in the delectable “tastes of home.” Finally, in 1970, along with his wife and brother, this necessity drove him to open a small store in Jackson Heights, Queens, calling it “House of Spices” — one of the city’s first stores devoted to Indian food products.

To say that his idea was well received would be an understatement. Today, House of Spices (India) Inc. is a leader in flavor and one of the most respected and familiar names in the industry. They manufacture, market and distribute spices, grains, flours, ghee, pastes, condiments and other flavorful products from twelve major distribution centers across North America to the entire South Asian food industry — retail outlets, food manufacturers and food-service businesses. Soni’s children, Neil and Amrapali, manage the family-owned business which continues to expand rapidly — and that’s where Hillphoenix and Zone Mechanical come into the story.



About four years ago, House of Spices decided to build their Chicago-area facility in Elk Grove Village, IL to better serve the Midwest region of the country. They reached out to the highly regarded and experienced refrigeration contractor, Zone Mechanical, to help determine the best solution to their new facility’s refrigeration needs.

Although House of Spices was not sure initially what direction they wanted to go with refrigeration, they had decided on one thing for

sure — they wished to have a solution that was HFC-free. “We were aware of the growing threats to our environment and the onslaught of resulting regulatory actions,” said Abraham Philip, Midwest regional manager for House of Spices (India) Inc. “We wanted to be part of the solution and not part of the problem.” Abraham went on to say, “We felt an obligation to protect our neighbors, our community and our planet as a whole by establishing ‘environmentally friendly’ as our top priority.”

Based on the House of Spices stated priority, Brent Beishuizen, Service Manager for Zone Mechanical, introduced the idea of using a Hillphoenix Advansor CO<sub>2</sub> booster system to meet the refrigeration needs of the new facility. Brent configured the system to accommodate the following needs:

- Two (2) freezers, each at a different temperature — one running @ 0 °F and the other running @ -10 °F — with 3 compressors serving the low-temp loads.

- Two (2) coolers, each at a different temperature — one running @ 40 °F with the other running @ 33 °F — with 4 compressors serving the medium-temp loads.
- Two (2) different suction groups — one low-temp and one medium-temp.
- Electric defrost — noting that the pulldown of CO<sub>2</sub> is much faster than with other typical DX system refrigerants.
- Micro Thermo controller technology package for complete operational system control and performance monitoring.



Not being familiar with CO<sub>2</sub> refrigeration, House of Spices had some initial questions and a few concerns. Brent set out to educate them and answer any questions they might have. “We wondered about system cost and gas availability,” remembers House of Spices’ Philip. “The folks at Zone Mechanical did a great job of answering all of our questions. They showed us that a Hillphoenix CO<sub>2</sub> system installation cost was quite affordable, made even more attractive with the inherent CO<sub>2</sub> system benefits, including reduced maintenance cost and low-cost, readily available gas.” But perhaps the biggest attraction to House of Spices was the “future-proof” nature of a natural refrigerant like CO<sub>2</sub> with its essentially non-existent global warming potential (GWP) and ozone depletion potential (ODP) characteristics. Besides meeting their stated priority of being environmentally friendly, “It gave us the assurance that we would not



have to go through any costly refrigerant changeout in the future — a peace-of-mind for our business going forward that meant a great deal to us,” added Philip.

Zone Mechanical’s Beishuizen remembers overcoming the final hurdle in the decision-making process. “House of Spices, like others who did not have a great deal of familiarity with CO<sub>2</sub> booster systems, had heard the rumblings of the ‘high

pressures’ involved with these systems and wondered aloud as to whether this might be a cause for concern,” he said.

“I showed them that the high pressure in a CO<sub>2</sub> booster system was completely contained to the high side of the

refrigeration rack (gas cooler) and not in the product coolers or freezers on the production floor,” he continued. “I also pointed out that the pressures are linked to the ambient temperature. Higher pressures are present only when the system is operating in transcritical mode which occurs when the ambient temp exceeds 80 °F. These kinds of ambient temps only occur during the peak daylight hours of about two months a year (July and August). The remainder of the summer months sees pressures under 1000 psi with winter values in the area of 600 psi – 700 psi,” he concluded. Although there were a number of facets of the new CO<sub>2</sub> system that pleased House of Spices, ranging from better performance to improved energy efficiency, the usage of the Micro Thermo control technology and the value that it brought them stood out as one of the strongest selling points. Brent Beishuizen elaborated on how the Micro Thermo technology makes servicing systems so much easier and effective. “With the Micro Thermo control technology, total system operational info is centrally available to the service technician via a software application, allowing system performance analysis and diagnostics to be done without even physically seeing the system’s components.” Brent gave numerous examples of this, but among them, some of the more key aspects to him were:

- Pulling up superheats of each coil
- Display of suction pressures and temperatures
- Display of coil temperatures
- Display of liquid pressures, which among other things, allowed the technician to know whether a load was iced up or just going through defrost.

Abraham Philip also spoke highly of the value the Micro Thermo technology brought House of Spices. “We really like that a lot! If there are any system alerts or alarms of any nature, we are immediately notified with an auto email from the Micro Thermo system. Upon receiving that email, we can log into the system remotely from wherever we are, check the specifics of the alert, and determine the required response and associated urgency. So far, the only alarms we have received have been due to temperature warnings caused by cooler or freezer doors being left open.” He summarized his feelings by saying, “It sure helps us to sleep well at night!”

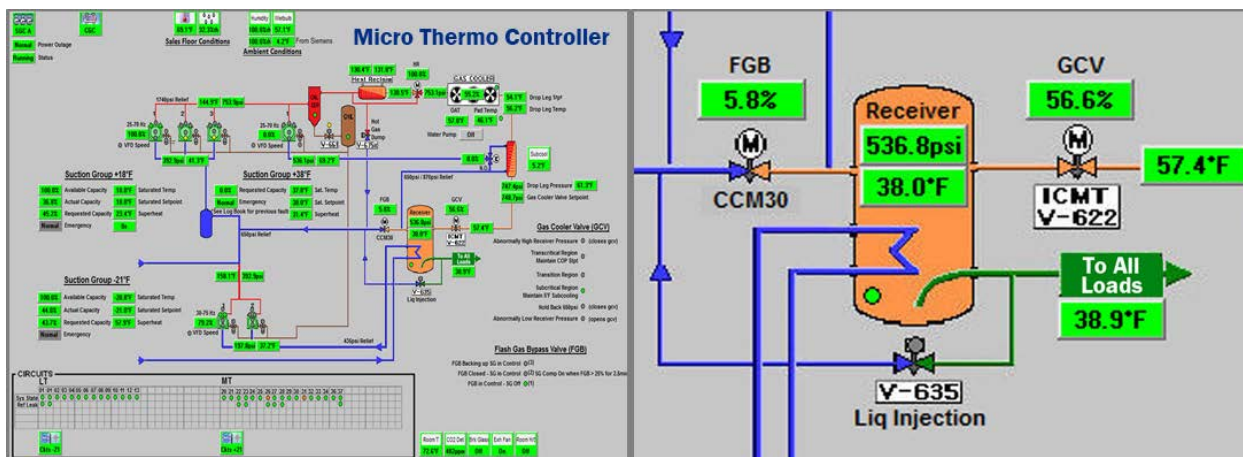

Brent Beishuizen harbors very strong feelings about the usage of CO<sub>2</sub> refrigeration systems. “Hillphoenix CO<sub>2</sub> booster systems are a very solid, proven platform. We’ve installed over 20 of these systems and every customer involved has been more than pleased with the results. They are going to be around a long time — they are the way of the future in both industrial and commercial applications!” Abraham Philip from House of Spices wholeheartedly agrees. “We’ve had no issues of note with our Hillphoenix CO<sub>2</sub> booster system installation. Zone Mechanical’s team has done a fine job and we feel comfortable knowing that if any issue does arise, they will be there to support us and quickly remedy it. It’s a great feeling to know that our business is protected because what we have is ‘future-proof’.”

Meanwhile, House of Spices continues to expand. They have acquired property in New Jersey where they plan to build an 80,000 sq. ft. facility with a 20,000 sq. ft. freezer unit. Perhaps the most profound testament to the satisfaction they have with their Hillphoenix CO<sub>2</sub> installation in Chicago is summed up in the words of Abraham Philip when he says, “We will only use CO<sub>2</sub> for this new facility and any other that we build in the future. We highly recommend using a Hillphoenix CO<sub>2</sub> booster system to anyone considering a commercial freezer for their operation.” So, on this evening and every evening, all across this great land of ours, customers of House of Spices will be sitting down at the dinner table to partake in their favorite delectable dish and once again spoil their taste buds with some of India’s finest cuisine. Little will they know just how Hillphoenix and Zone Mechanical teamed up to put a little spice in their lives — but now, you know!